

## Panel mounting frames - FOC-V14-F1ZNI-EM/SJB - 1413964

Please be informed that the data shown in this PDF Document is generated from our Online Catalog. Please find the complete data in the user's documentation. Our General Terms of Use for Downloads are valid (<http://phoenixcontact.com/download>)



SC-RJ panel mounting frame, IP67, for push-pull interlocking, metal, for rectangular mounting cutout, with seal and mounting screws, incl. SC-RJ coupling



### Key Commercial Data

Packing unit	1 pc
GTIN	 4 055626 082387
GTIN	4055626082387

### Technical data

#### Environmental Product Compliance

China RoHS	Environmentally friendly use period: unlimited = EFUP-e
	No hazardous substances above threshold values

### Drawings

# Panel mounting frames - FOC-V14-F1ZNI-EM/SJB - 1413964

Drilling diagram

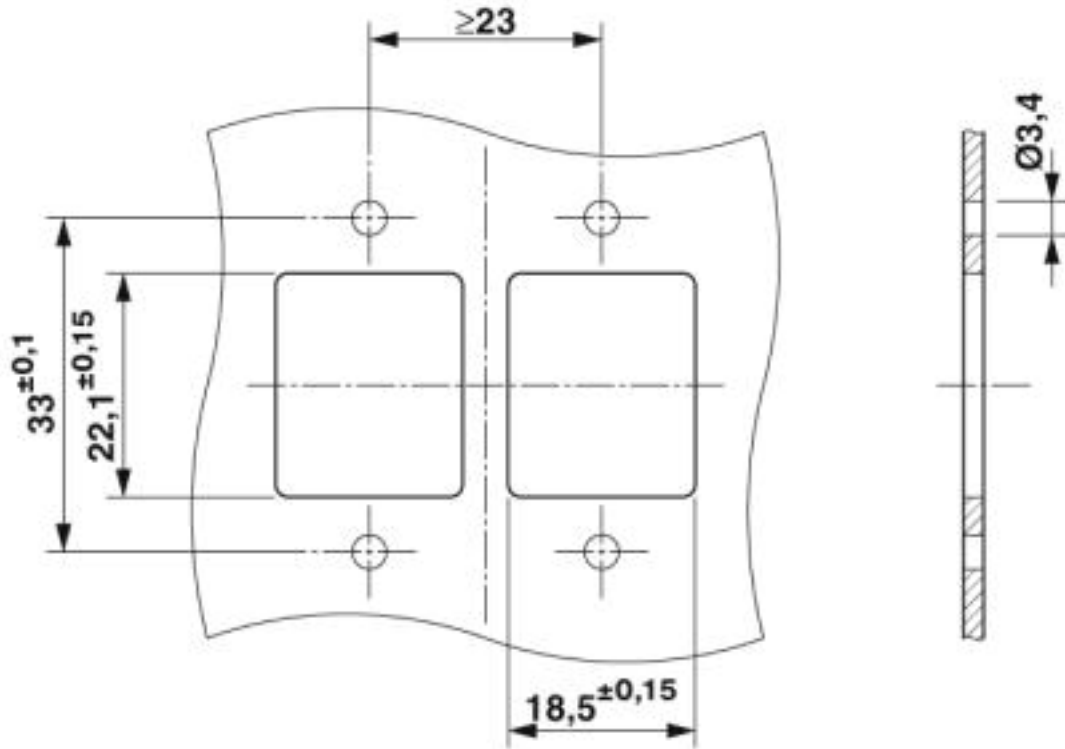

Dimensional drawing

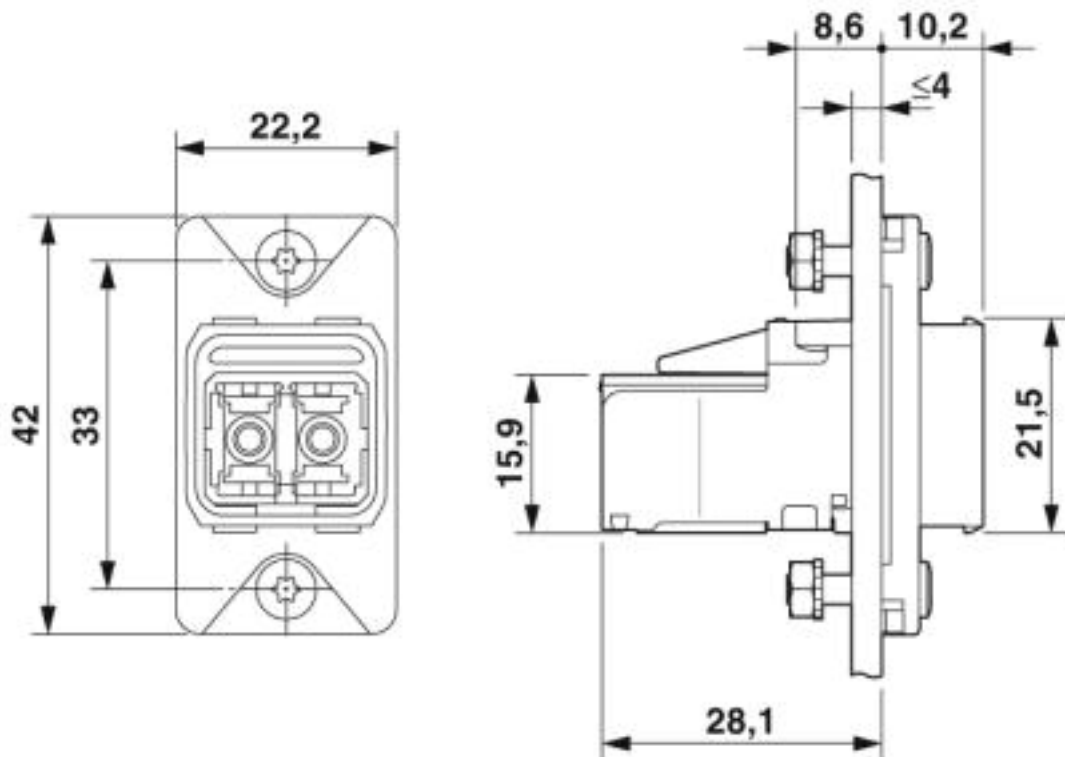

# Panel mounting frames - FOC-V14-F1ZNI-EM/SJB - 1413964

## Classifications

### eCl@ss

eCl@ss 10.0.1	27440210
eCl@ss 4.0	272607xx
eCl@ss 4.1	27260701
eCl@ss 5.0	27260701
eCl@ss 5.1	27260701
eCl@ss 6.0	27261200
eCl@ss 7.0	27440210
eCl@ss 8.0	27440210
eCl@ss 9.0	27440210

### ETIM

ETIM 3.0	EC002310
ETIM 4.0	EC002310
ETIM 5.0	EC002310
ETIM 6.0	EC002310
ETIM 7.0	EC002310

### UNSPSC

UNSPSC 6.01	31261501
UNSPSC 7.0901	31261501
UNSPSC 11	31261501
UNSPSC 12.01	31261501
UNSPSC 13.2	31261501
UNSPSC 18.0	39121421
UNSPSC 19.0	39121421
UNSPSC 20.0	39121421
UNSPSC 21.0	39121421

## Approvals

### Approvals

---

Approvals

EAC / UL Listed

---

Ex Approvals

---

### Approval details

## Panel mounting frames - FOC-V14-F1ZNI-EM/SJB - 1413964

### Approvals

EAC		B.01687
-----	--	---------

UL Listed		<a href="http://database.ul.com/cgi-bin/XYV/template/LISEXT/1FRAME/index.htm">http://database.ul.com/cgi-bin/XYV/template/LISEXT/1FRAME/index.htm</a> E308814-20180830
-----------	--	--

### Accessories

#### Accessories

Fiber optic connector (cable side)

FO connectors - FOC-V14-C1ZNI-S/SJFP - 1407896



Push-pull connector (version 14), die-cast zinc, with SC-RJ insert for POF, for cable diameter of 5.5 mm ... 10 mm

#### Panel mounting frame

Screw set - CUC-V14-A-SCREW-M3:20 - 1413987



Screw set, M3 for panel mounting frames

Protective covers - CUC-V14-A1PBK-PC - 1413970



Protective covers, degree of protection: IP65/IP67

Protective covers - CUC-V14-A1RBK-PC - 1413985



Protective covers, degree of protection: IP65/IP67

## Panel mounting frames - FOC-V14-F1ZNI-EM/SJB - 1413964

### Accessories

---

Panel mounting frames - CUC-V14-A1ZNI-R45 - 1413988



45° adapter for panel mounting frames

---

Panel mounting frames - CUC-V14-A1ZNI-S180 - 1413989



Spacer for panel mounting frames

---

Strain relief - CUC-V14-A3ST-SR - 1413990



Strain relief, degree of protection: IP65/IP67, material: Stainless steel

---

Panel mounting frames - CUC-V14-A1PBK-BA:50 - 1413979



Holder for marking element

---

Phoenix Contact 2020 © - all rights reserved  
<http://www.phoenixcontact.com>

PHOENIX CONTACT GmbH & Co. KG  
Flachsmarktstr. 8  
32825 Blomberg  
Germany  
Tel. +49 5235 300  
Fax +49 5235 3 41200  
<http://www.phoenixcontact.com>