

Cable gland - G-INS-M12-S68N-NNES-S - 1411160

Please be informed that the data shown in this PDF Document is generated from our Online Catalog. Please find the complete data in the user's documentation. Our General Terms of Use for Downloads are valid (<http://phoenixcontact.com/download>)



Cable gland, cable gland material: Nickel-plated brass, external cable diameter 3 mm ... 6.5 mm, shielding: no, connecting thread: M12 x 1.5, color: silver, with O-ring



Key Commercial Data

Packing unit	10 pc
GTIN	
GTIN	4046356922968

Technical data

Dimensions

Length	27 mm
Wrench size, union nut	14 mm
Wrench size, support	14 mm
Hexagon angular dimension	15.5 mm
Length of the connecting thread	6 mm
Feed-through hole diameter	12.1 mm ... 12.3 mm
External cable diameter	3 mm ... 6.5 mm
	4 mm ... 6.5 mm (for UL 514 B)

Ambient conditions

Degree of protection (IP)	IP69 (DIN EN 60529 / IEC 60529)
	IP68 (5 bar, 30 min.)
	IP66
Degree of protection (NEMA)	4X
Ambient temperature (operation)	-40 °C ... 100 °C (static)

General

No. of conductors	1
Cable gland material	Nickel-plated brass

Cable gland - G-INS-M12-S68N-NNES-S - 1411160

Technical data

General

Material, insert	Polyamide 6
Cable seal material	CR
O-ring material	Perbunan
Shielded	no
Thread type on connection side	M12 x 1.5
Torque	5 Nm ± ()
Color	silver
Impact category	5
Execution of the strain relief	A
Assembly instructions	1) Mount screw connection support in the housing using the correct torque 2) Insert cable 3) Tighten union nut using the correct torque
Manufacturer	BIMED
Manufacturer Designation	BMBC-0S

Standards and Regulations

Halogen-free	no
--------------	----

Environmental Product Compliance

REACH SVHC	Lead 7439-92-1
China RoHS	Environmentally Friendly Use Period = 50 years
	For details about hazardous substances go to tab "Downloads", Category "Manufacturer's declaration"

Drawings

Cable gland - G-INS-M12-S68N-NNES-S - 1411160

Dimensional drawing

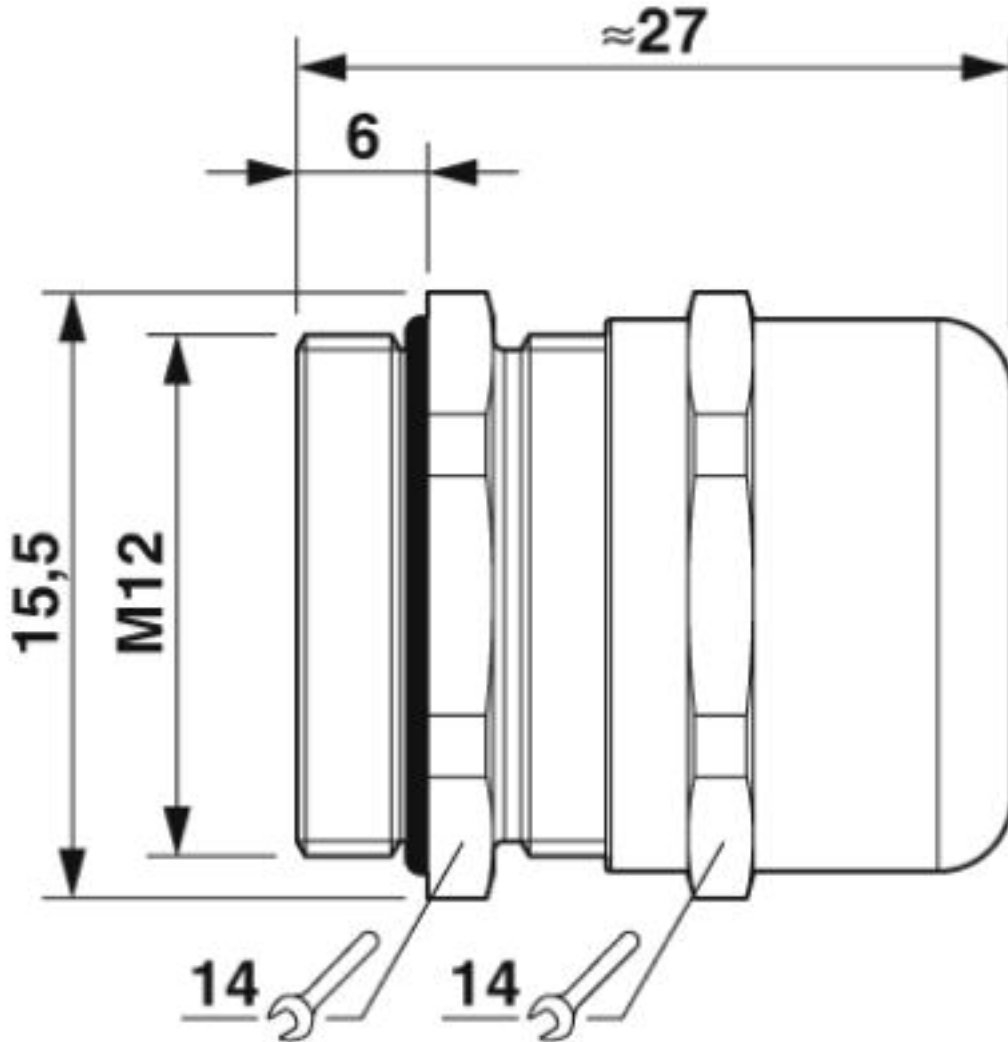

Dimensional drawing

Classifications

eCl@ss

eCl@ss 10.0.1	27144432
eCl@ss 4.0	27081000
eCl@ss 4.1	27081000
eCl@ss 5.0	27149100
eCl@ss 5.1	27081000
eCl@ss 6.0	27149100
eCl@ss 7.0	27149109
eCl@ss 8.0	27149109

Cable gland - G-INS-M12-S68N-NNES-S - 1411160

Classifications

eCl@ss

eCl@ss 9.0	27144432
------------	----------

ETIM

ETIM 4.0	EC000441
ETIM 5.0	EC000441
ETIM 6.0	EC000441
ETIM 7.0	EC000441

UNSPSC

UNSPSC 13.2	39121311
UNSPSC 18.0	39121311
UNSPSC 19.0	39121311
UNSPSC 20.0	39121311
UNSPSC 21.0	39121311

Approvals

Approvals

Approvals

UL Recognized / cUL Recognized / cULus Recognized

Ex Approvals

Approval details

UL Recognized		http://database.ul.com/cgi-bin/XYV/template/LISEXT/1FRAME/index.htm	E199260
---------------	--	---	---------

cUL Recognized		http://database.ul.com/cgi-bin/XYV/template/LISEXT/1FRAME/index.htm	E199260
----------------	--	---	---------

cULus Recognized			
------------------	--	--	--

Accessories

Accessories

Cable gland - G-INS-M12-S68N-NNES-S - 1411160

Accessories

Flat nut

Counter nut - A-INL-M12-N-S - 1411240



Counter nut, material: Brass, nickel-plated, for threads M12 x 1.5, color: silver

Sealing plugs

Closing cap - SEALING PLUG 5X12 RD - 1400253



Closing cap, material: PA, color: red

Phoenix Contact 2020 © - all rights reserved
<http://www.phoenixcontact.com>

PHOENIX CONTACT GmbH & Co. KG
Flachsmarktstr. 8
32825 Blomberg
Germany
Tel. +49 5235 300
Fax +49 5235 3 41200
<http://www.phoenixcontact.com>