

# HD-T1 SERIES

**New**

## LED Type Wafer Alignment Sensor



The use of a safe LED light beam now allows for high precision detection with a resolution of 30  $\mu\text{m}$  (1.181 mil)



### No safety measures are required at all

As a safe red LED is used as the light source, there is no need for time-consuming safety measures. The protective covers usually required when using laser beams are not needed, and FDA approval is not required in order to use this sensor in the US.

### High resolution of 30 $\mu\text{m}$ 1.181 mil

Although the HD-T1 series uses a red LED for its light source, it has the same high level of performance as laser sensors, thus enabling high precision detection.

### Easy installation

This unit utilizes a one-touch connector to connect the sensor head to the controller. The amount of wiring is therefore minimized, resulting in easy maintenance.

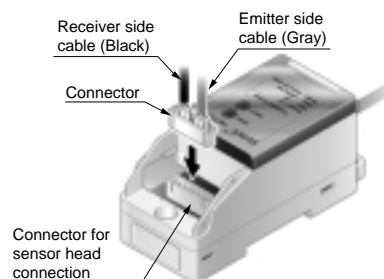

### No need for beam axis alignment

As both the receiver and the emitter are integrated into a single unit, there is no need to perform any troublesome alignment of the beam axis. In addition, as the HD-T1 series can perform its detection function over a broad area - with both a sensing range and a sensing width of 30 mm 1.181 in, this unit can be utilized for sensing wafers of many different sizes.

### Adjustment functions for both span and shift have been incorporated

In addition to the span adjustment function, a convenient shift adjustment function has also been incorporated into the analog output (1 to 5 V). The shift adjustment function allows the analog voltage to be shifted by up to  $\pm 0.5$  V.

### Low current consumption of 70 mA or less

The HD-T1 series has a maximum current consumption of only 70 mA, for both the sensor head and the controller. The current consumption is almost as low as that of photoelectric sensors.

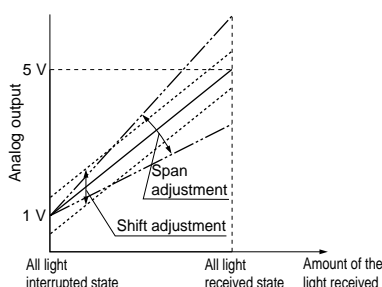

## APPLICATIONS

Detecting wafer eccentricities or notches



## ORDER GUIDE

**Sensor head** Make sure to use the sensor head and the controller together as a set.

Appearance	Sensing range	Sensing width	Model No.
	<div style="border: 1px solid gray; width: 20px; height: 10px; display: inline-block; vertical-align: middle;"></div> 30 mm 1.181 in (fixed) (Note)	30 mm 1.181 in	<b>HD-T1030</b>

Note: The value is in a state that the sensor is mounted on the mounting base at the time of factory shipment.

**Controller** Make sure to use the sensor head and the controller together as a set.

Appearance	Model No.	Output
	<b>HD-T1C</b>	Analog voltage • Output voltage: 1 to 5 V

# HD-T1

## SPECIFICATIONS

### Sensor head

Item	Model No.	HD-T1030
Applicable controller		HD-T1C
Sensing width		30 mm 1.181 in (Linearity is specified at 28 mm 1.102 in width.)
Sensing range		30 mm 1.181 in (fixed)(Note)
Environmental resistance	Pollution degree	3 (Industrial environment)
	Ambient temperature	0 to +40 °C +32 to +104 °F (No dew condensation), Storage: -20 to +55 °C -4 to +131 °F
	Ambient humidity	35 to 85 % RH, Storage: 35 to 85 % RH
	Ambient illuminance	Incandescent light: 3,000 lx at the light-receiving face, Fluorescent light: 3,000 lx at the light-receiving face
	Voltage withstandability	1,000 V AC for one min. between all supply terminals connected together and enclosure
	Insulation resistance	20 MΩ, or more, with 250 V DC megger between all supply terminals connected together and enclosure
	Vibration resistance	10 to 150 Hz frequency, 0.75 mm 0.030 in amplitude in X, Y and Z directions for two hours each
	Shock resistance	490 m/s <sup>2</sup> acceleration (50 G approx.) in X, Y and Z directions for three times each
Emitting element		Red LED (Peak emission wavelength: 650 nm 0.026 mil)
Receiving element		Photodiode
Material		Enclosure: PEI, Front cover: Glass, Mounting base: Aluminum
Cable		Heat-resistant PVC cable, 0.5 m 1.640 ft long, with a connector at the end
Weight		150 g approx.

Note: The value is in a state that the sensor is mounted on the mounting base at the time of factory shipment.

### Controller

Item	Model No.	HD-T1C
Applicable sensor head		HD-T1030
Supply voltage		24 V DC ± 10 % Ripple P-P 10 % or less
Current consumption		70 mA or less (Including sensor head)
Analog output		Analog voltage • Output voltage: 1 ± 0.5 V (all light interrupted) to 5 ± 0.5 V (all light received) • Output impedance: 75 Ω
	Response time	0.5 ms or less (8 V/ms or more)
	Resolution	30 μm 1.181 mil (Note 1)
	Linearity	± 1.0 % F.S. (at 28 mm 1.102 in sensing width of the sensing center)(Note 2)
	Temperature characteristics	± 0.1 % F.S./°C (at 24 ± 2 °C 75.2 ± 35.6 °F)(Note 2)
Span adjustment function		Span of the analog output voltage is adjusted. 15-turn endless adjuster
Shift adjustment function		Offset of the analog output voltage is adjusted. 15-turn endless adjuster
Warming-up period		30 min. or more
Environmental resistance	Pollution degree	3 (Industrial environment)
	Ambient temperature	0 to +40 °C +32 to +104 °F (No dew condensation), Storage: -20 to +70 °C -4 to +158 °F
	Ambient humidity	35 to 85 % RH, Storage: 35 to 85 % RH
	EMC	EN 50081-2, EN 61000-6-2
	Voltage withstandability	1,000 V AC for one min. between all supply terminals connected together and enclosure
	Insulation resistance	20 MΩ, or more, with 250 V DC megger between all supply terminals connected together and enclosure
	Vibration resistance	10 to 150 Hz frequency, 0.75 mm 0.030 in amplitude in X, Y and Z directions for two hours each
	Shock resistance	490 m/s <sup>2</sup> acceleration (50 G approx.) in X, Y and Z directions for three times each
Material		Enclosure: Heat-resistant ABS, Connector cover: Heat-resistant ABS, Adjuster cover: Polycarbonate
Cable		0.22 mm <sup>2</sup> 3-core heat-resistant PVC cable, 0.3 m 0.984 ft long
Cable extension		Extension up to total 3 m 9.843 ft is possible with 0.3 mm <sup>2</sup> , or more, heat-resistant PVC cable.
Weight		85 g approx.

Notes: 1) Resolution refers to the peak to peak distance conversion value of analog output (in the frequency band below 20 MHz).  
2) This is the representative example of measurement with a combination of sensor head and controller.

## I/O CIRCUIT AND WIRING DIAGRAMS (Controller)

### I/O circuit diagram

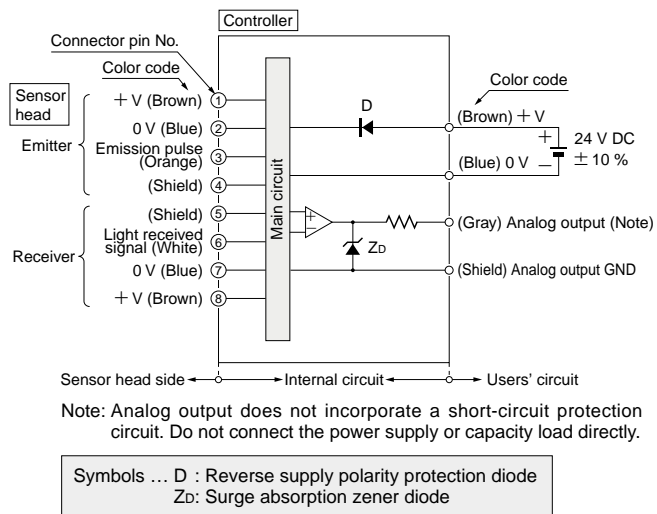

### Terminal arrangement

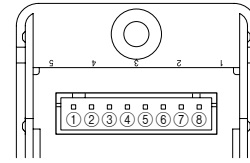

Terminal No.	Description
①	+ V
②	0 V
③	Emission pulse
④	Shield
⑤	Shield
⑥	Light received signal
⑦	0 V
⑧	+ V

## PRECAUTIONS FOR PROPER USE



This product is not a safety sensor. Its use is not intended or designed to protect life and prevent body injury or property damage from dangerous parts of machinery. It is a normal object detection sensor.

- Make sure to use the sensor head and the controller together as a set.

### Mounting

#### Sensor head

- Mount the sensor head using 2 pcs. M4 hexagon-socket-head bolts (please arrange separately) with a tightening torque of 0.5 N·m or less.
- Do not remove the screws fixing the emitter / receiver and the mounting base. If removed, the output value will change.
- Do not fix with the screws, using the mounting hole on the side of emitter / receiver.

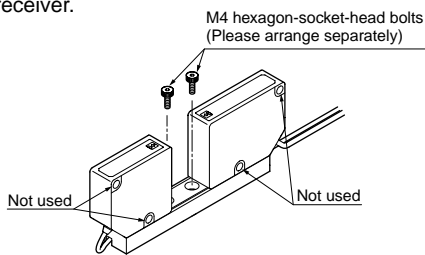

#### Controller

##### <In case of using DIN rail>

- ① Fit the front part of the mounting section of the unit on the 35 mm 1.378 in width DIN rail, pressing the stopper towards the arrow (the stopper is locked) shown in the right figure.
  - ② Press down the rear part of the mounting section of the unit on the 35 mm 1.378 in width DIN rail to fit it.
- ※For removal, insert a flat-bladed screwdriver into the groove of the stopper and pull the handle backwards.

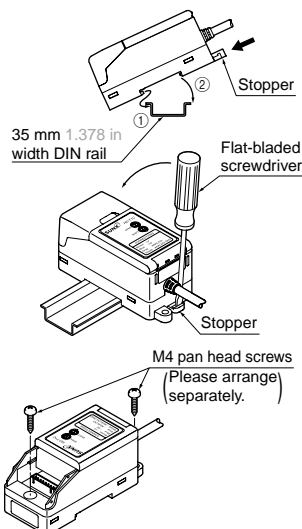

##### <In case of using screws>

- ① Mount using M4 pan head screws with a tightening torque of 1.2 N·m or less.

### Wiring

- Make sure that the power supply is off while wiring.
- Analog output does not incorporate a short-circuit protection circuit. Do not connect the power supply or capacity load directly.
- Care should be taken that static electricity is not applied to the connector during wiring. It may damage the product.
- Take care that wrong wiring will damage the product.
- Verify that the supply voltage variation is within the rating.
- If power is supplied from a commercial switching regulator, ensure that the frame ground (F.G.) terminal of the power supply is connected to an actual ground.
- In case noise generating equipment (switching regulator, inverter motor, etc.) is used in the vicinity of the sensor head and the controller, connect the frame ground (F.G.) terminal of the equipment to an actual ground.
- Do not run the wires together with high-voltage lines or power lines or put them in the same raceway. This can cause malfunction due to induction.
- Cable extension is possible up to total 3 m 9.843 ft with 0.3 mm<sup>2</sup>, or more, cable. Note that the cable length of the sensor head cannot be changed.
- Do not apply stress such as forced bending and pulling to the cable joint.
- Make sure to use an isolation transformer for the DC power supply. If an autotransformer (single winding transformer) is used, this product or the power supply may get damaged.
- In case a surge is generated in the used power supply, connect a surge absorber to the supply and absorb the surge.

#### Connection between the sensor head and the controller

- Make sure that the power supply is off while connecting the sensor head to controller.
- When the sensor head is connected to the controller, hold the connector of sensor head, inserting it to the end of the connector for sensor head connection of the controller.

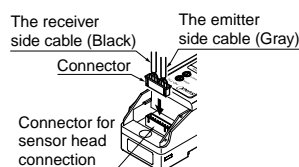

※For removal, hold the connector of sensor head and pull it straight.

Note: Do not pull by holding the cable, as this can cause a cable-break.

# HD-T1

## PRECAUTIONS FOR PROPER USE

### Functional description (Controller)

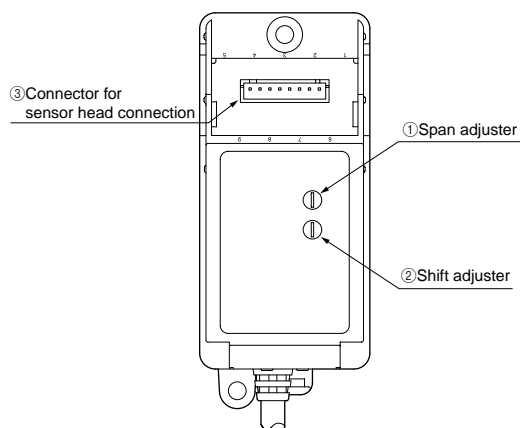

	Description	Function
①	Span adjuster	This is used for adjusting the output voltage range of the analog output.
②	Shift adjuster	This is used for adjusting the offset voltage (the analog output voltage value in all light interrupted state) of the analog output.
③	Connector for sensor head connection	Connector for sensor head connection

### Adjustment

#### Adjustment of analog output

- The following figure shows the relationship between span and shift adjustments and analog output.

#### <To adjust within the range of 1 to 5 V>

- Adjust the shift adjuster such that the analog output is 1 V in **all light interrupted state**.
- Adjust the span adjuster such that the analog output is 5 V in **all light received state**.
- For more accurate adjustment, perform steps ① and ② again.

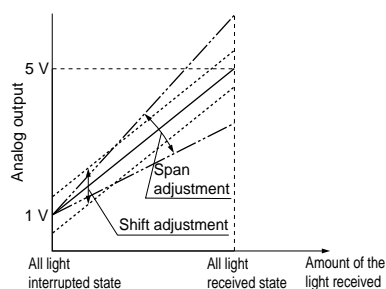

### Application of shift adjuster

- To set a certain analog output voltage for a light interrupted width, use the shift adjuster to adjust the analog output voltage within approx.  $\pm 0.5$  V.

(Ex.) When the analog output voltage, 2.51 V for a light interrupted width, is set to 3 V.

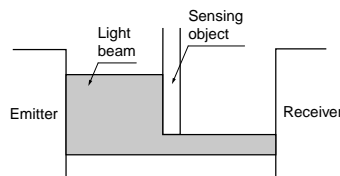

	Before adjustment	After adjustment
All light interrupted state	1 V }	1.49 V }
Sensing state	2.51 V }	<b>3 V</b> }
All light received state	5 V	5.49 V

### Others

- Do not use during the initial transient time (0.5 sec. approx.) after the power supply is switched on.
- Take care that the sensor is not directly exposed to fluorescent light from a rapid-starter lamp or a high frequency lighting device, as it may affect the sensing performance.
- Avoid dust, dirt, and steam.
- Take care that the product does not come in direct contact water, oil, grease or organic solvents, such as, thinner, etc.
- This product outputs according to the amount of LED light received. Optical power varies between the center and the periphery of sensing range, and note that dimensional accuracy cannot be assured.
- Do not allow any water, oil, fingerprints, etc., which may refract light, or dust, dirt, etc., which may block light, to stick to the emitting / receiving surfaces of the sensor head. In case they are present, wipe them with a clean, dust-free soft cloth or lens paper.
- If the sensing object is specular or transparent object, note that accurate measurement may not be possible.
- This sensor is suitable for indoor use only.
- Never disassemble, repair or modification etc. the product.

## DIMENSIONS (Unit: mm in)

### HD-T1030 Sensor head

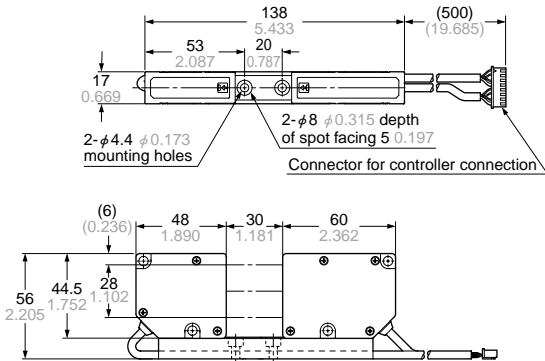

### HD-T1C Controller

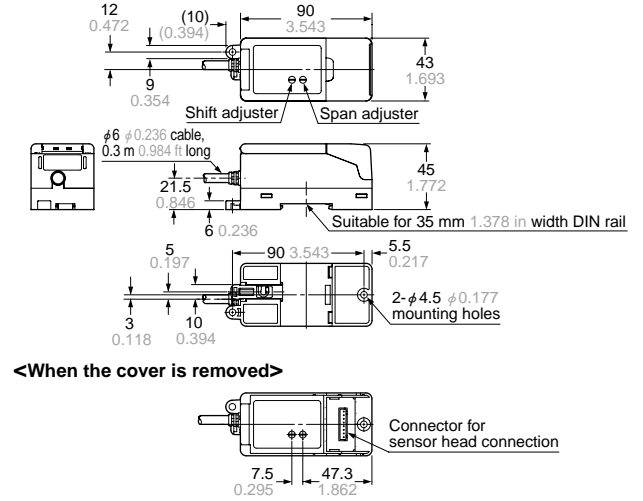

M-DW1

Glass Substrate / Wafer Sensing

M

HD-T1

Liquid Leak / Liquid Level Sensing

FD-F7

FT-F9

FX-301-F

EX-F70/F60