

Transfer or duplication of this document as well as the utilisation or communication of its content are not permitted unless express consent is granted. Violations give rise to claims for damages. All rights reserved in case of patent, utility model or design patent registrations.



**Ratings**

Use Group **B**  
 Rated Voltage **300V**  
 Rated Current **6A**  
 Rated Wire Size  
     solid **AWG 28-16**  
     flexible **AWG 28-16**  
 Screw Size **M2**

**Insulating Material**

Material **PA 6.6**  
 Flammability Class **UL 94 V-0**

**Materials**

Clamp **Brass**  
 Screw **Stainless Steel**  
 Solder Tag **Steel**  
 Temperature Range **-40° C ~ 105° C**  
 RoHS Compliant

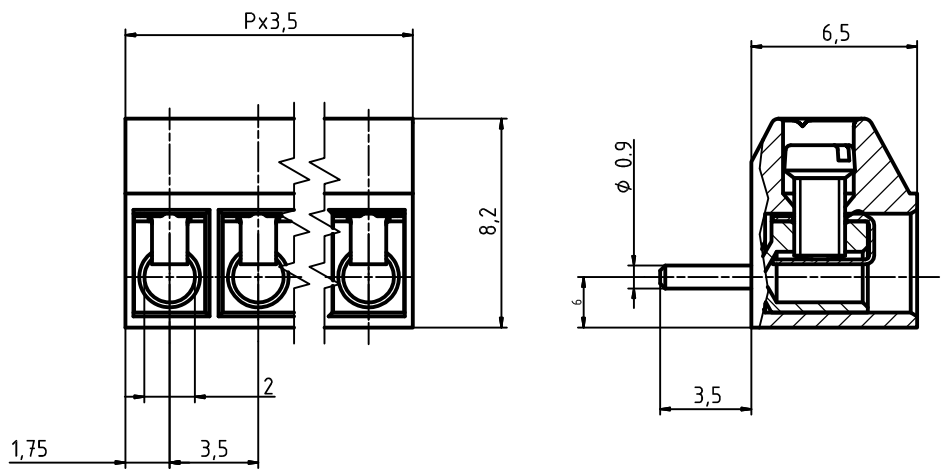

Part No.: **ED550/XDS**

No. of Poles  
 02 2 Poles  
 03 3 Poles  
 ... ..  
 16 16 Poles

DWG	WF. Zhang	DATE	2017.09.11	UNITS:	MM	SHEET:	1 OF 1	Tolerance
CHK.	WF. Zhang	DATE	2017.09.11	SCALE:	NONE 5:1 ( : )	REV:	A	X. ±0.50
APP.		DATE		TITLE:	ED550DS series 3.5 mm, one piece wire protector, vertical wire entry			X.X ±0.30
				PART NO.	ED550/XDS			X.XX ±0.10
				DWG NO.	ED550/XDS.DWG			X° ±1°

△				
SIGN	DESCRIPTION	CHK.	DATE	ON-SHORE TECHNOLOGY, INC.

