



Advanced functionality in an ultra compact design



50 to 400 W Pulse Train Servo Drives and AC Servomotors

-
- » Increase productivity
 - » Solve equipment problems
 - » Maximize performance
 - » Improve accuracy
-

Automation...simple...powerful.

R7-SERIES SERVOS

Compact Design, Easy Application and Advanced Functions



Operation

Adaptive Vibration suppression:

Mechanical vibration is controlled with a vibration control function and adaptive filter. Suitable for Systems with Low Mechanical Rigidity.

Improve Tact Time:

Significantly faster command pulse frequency.

Maintenance

Simplify maintenance using the CX-Drive Software in the CX-One Suite.

Assembly

Installation:

Mount the drive to the DIN Rail using the optional adapter.

Design

Palm-size design:

Reduces the Control Panel.

Simple Integration:

Easy control from PLC with the Smart FB Library. Reduces programming costs.

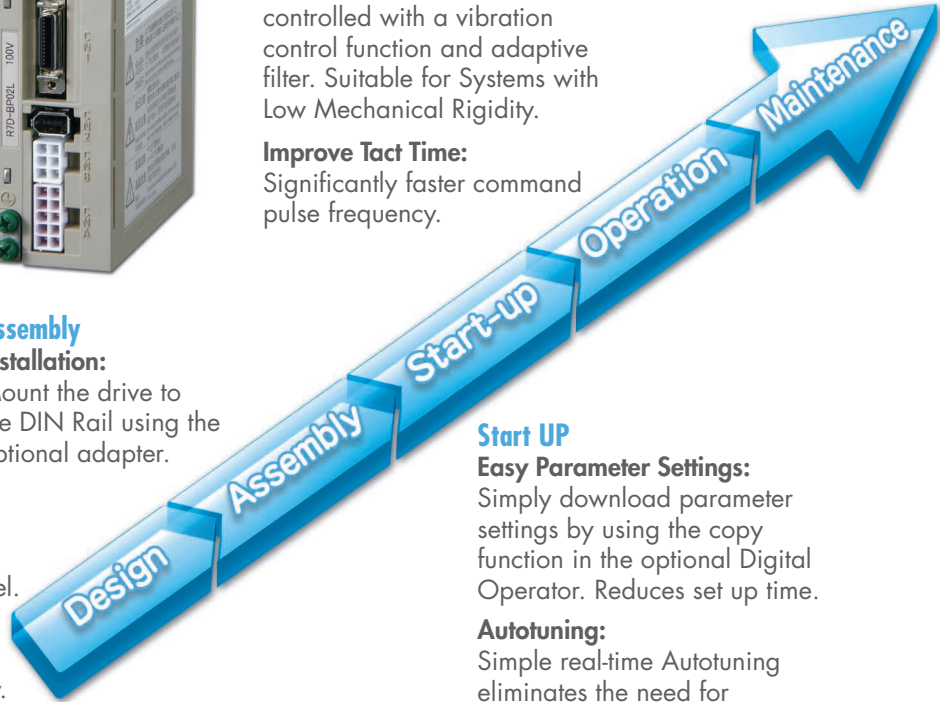

Start UP

Easy Parameter Settings:

Simply download parameter settings by using the copy function in the optional Digital Operator. Reduces set up time.

Autotuning:

Simple real-time Autotuning eliminates the need for complicated adjustments. Reducing start up time.

Integrated development environment reduces your total cost of ownership.

The Servo system can be managed from design to maintenance with the CX-One Automation Suite.

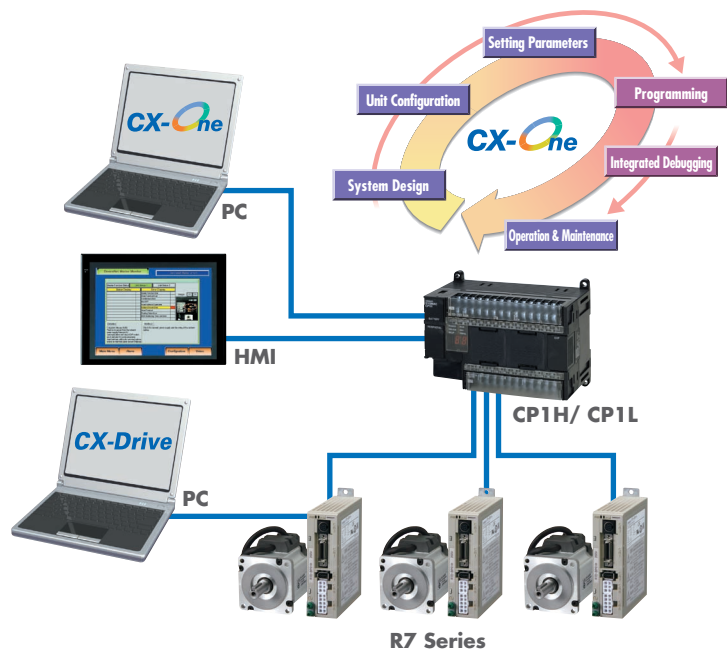

Setting & Programming

Easy programming with the Smart FB Library



Parameter Editing & Monitoring

The Servomotor parameters can be edited, monitored, and saved with the CX-Drive.

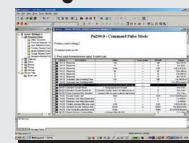

Alarm & Maintenance

Easy monitoring of the Drive errors



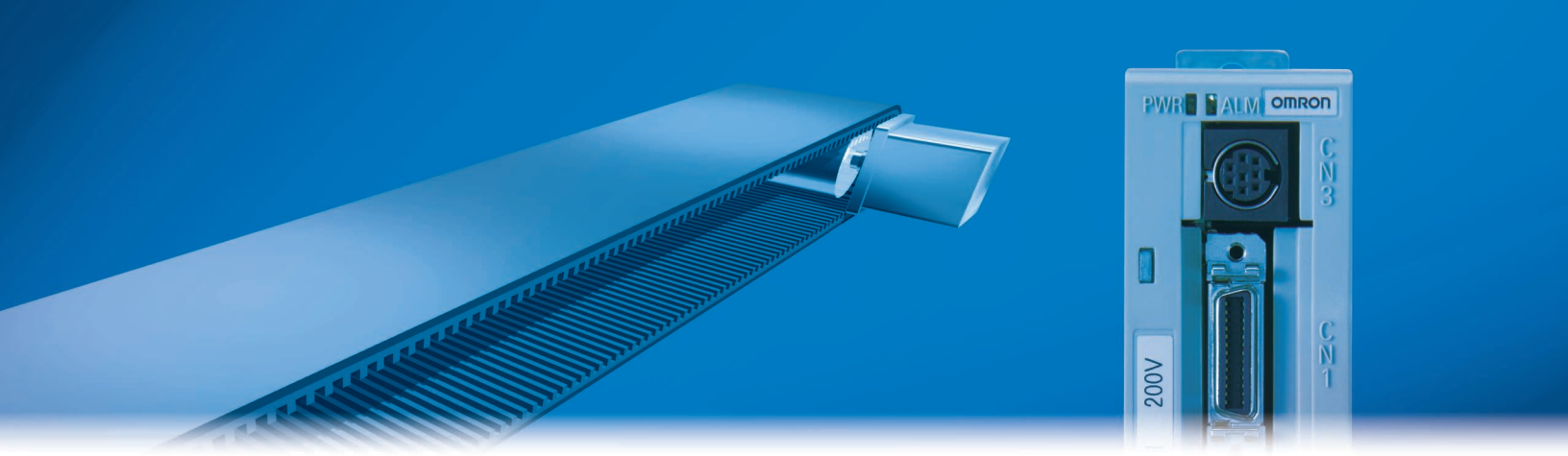

Ideal for a Wide Range of Applications: Ball Screws, Conveyor belts, X-Y Tables and more...

Compact!

A Super-compact, High-performance Servo System That's Easy to Use.

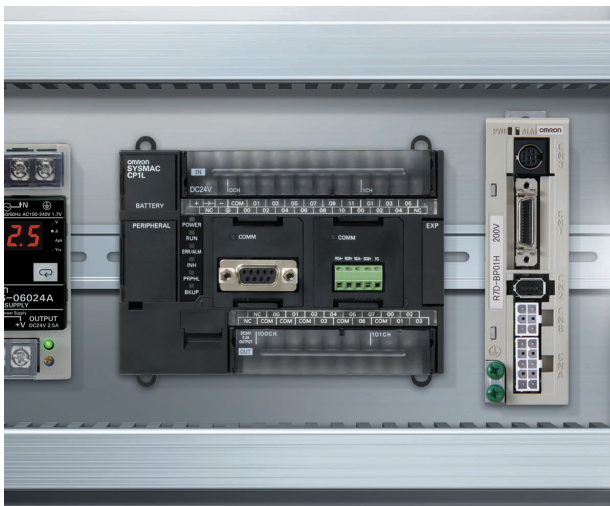

Smaller Servo Drives for Multi-axis Applications

The super-compact R7-Series is now even smaller. The footprint has been reduced by 52% from previous models minimizing control panel size.

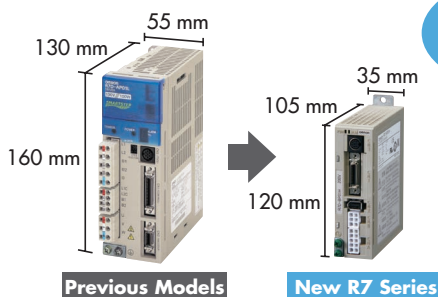

Easy!

Real time autotuning sets the optimum gain.

An auto-tuning function calculates the device load in real time and automatically sets the optimum gain to simplify the adjustment procedure.

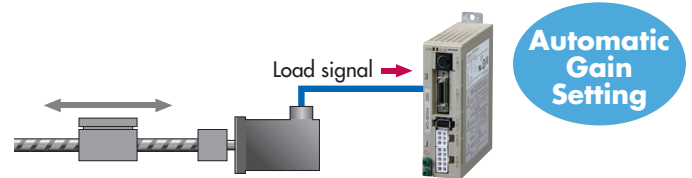

Installation

The Servo Drive can be mounted onto a DIN Rail by using the DIN Rail Mounting Unit (sold separately) for easier assembly and easier maintenance.



Easy Parameter Settings for Mass Production

Parameter can be easily set for many Servo Drives using the copy function in the Digital Operator, enabling easier assembly work in mass production lines.

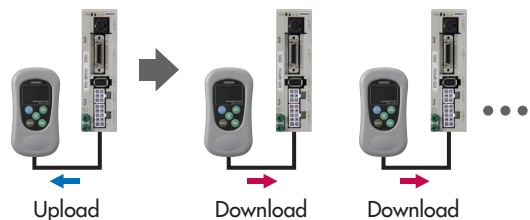



Advanced functionality!

Adaptive Vibration Suppression

The resonant frequency is automatically monitored to remove vibration using the adaptive filter. Even if the resonant frequency changes due to low mechanical rigidity, real time evaluation automatically follows the changes to reduce the effect of vibration.

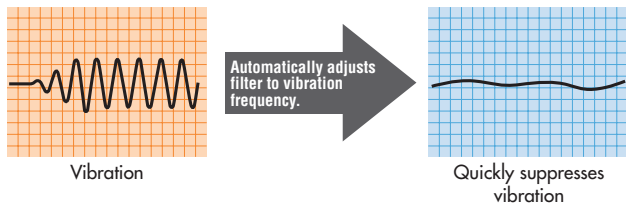

Reducing the amount of vibration improves positioning time and accuracy.

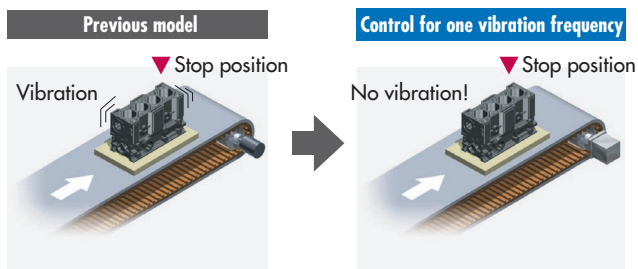

Reduce Process Cycle Time

The R7- Series accepts command pulse frequencies up to 500 kpps enabling high-speed positioning and high-precision control.

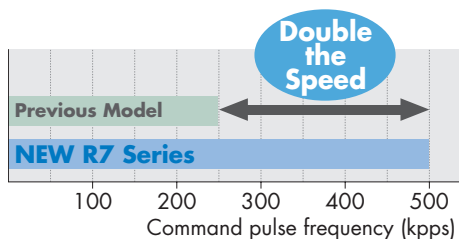

Closed loop system

The present position can be checked using the feedback pulse sent from the Servo Drive to the Controller, allowing positioning errors due to mechanical problems to be monitored and eliminated in the Controller.

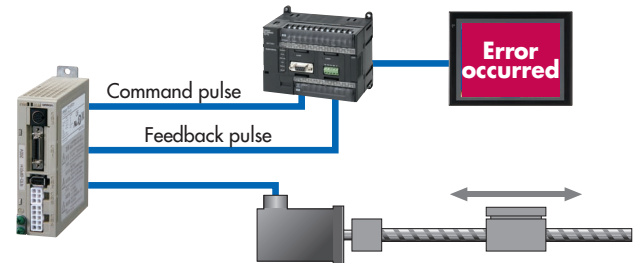

Simplified Synchronization: It is also possible to input encoder output signals directly into the servo drive.

Torque limiting function

Set two torque limits, and switch between them. Great for application, such as pressing or part insertion.

Torque limiting reduces machine or work piece breakdown occurrence.

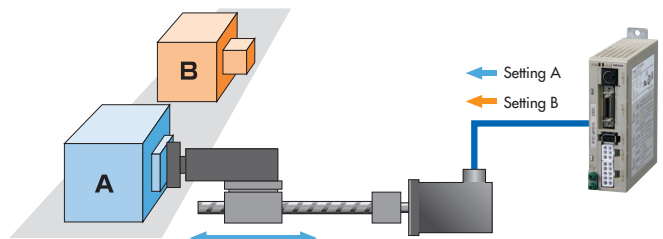

Servo Drive Model Numbers

The model number provides information such as the Servo Drive type, the applicable Servomotor capacity, and the power supply voltage.

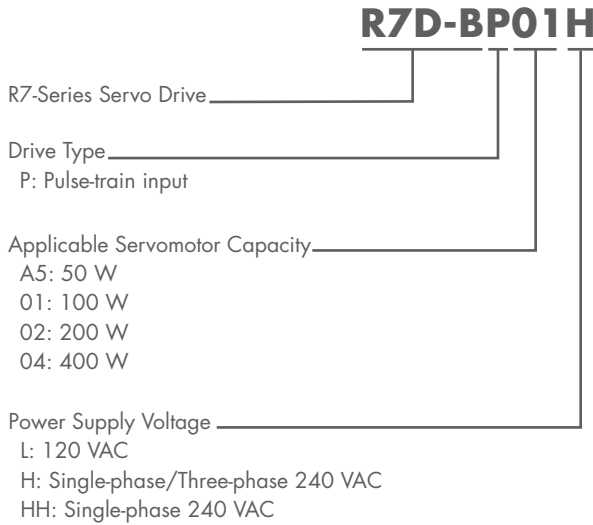

Servomotor Model Numbers

The model number provides information such as the Servomotor type, Servomotor capacity, rated speed and options.

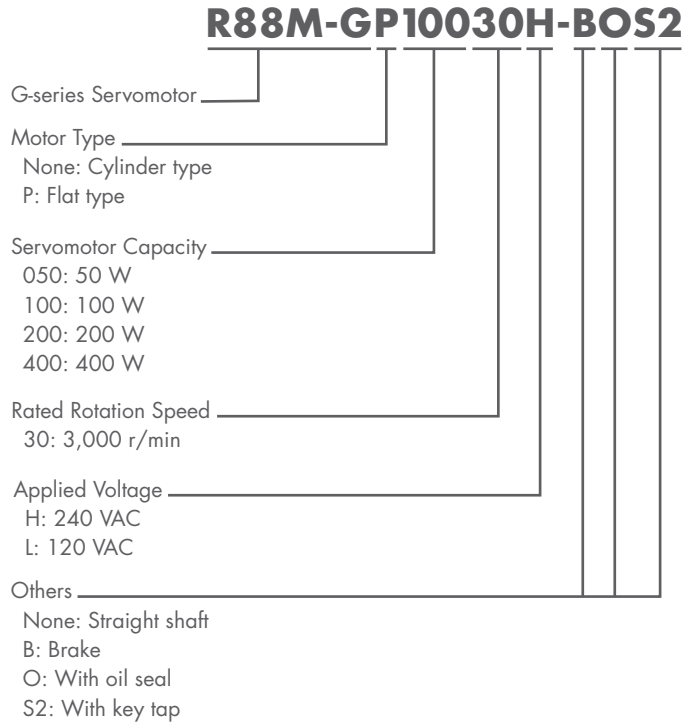

Servo Drive-Servomotor Combinations

Only the Servomotor and Servo Drive combinations listed here can be used. Do not use other combinations.

Cylindrical Servomotor

Servomotors Combinations

Voltage	Servo Drive	Rated output	Servomotor	
	Pulse-train input		Without brake	With brake
Single-phase 120VAC	R 7D-BPA5L	50 W	R 88M-G05030H-S2	R 88M-G05030H-BS2
	R 7D-BP01L	100 W	R 88M-G10030L-S2	R 88M-G10030L-BS2
	R 7D-BP02L	200 W	R 88M-G20030L-S2	R 88M-G20030L-BS2
Single-phase 240 VAC	R7D-BP01H	50 W	R 88M-G05030H-S2	R 88M-G05030H-BS2
		100 W	R 88M-G10030H-S2	R 88M-G10030H-BS2
	R 7D-BP02HH	200 W	R 88M-G20030H-S2	R 88M-G20030H-BS2
	R 7D-BP04H	400 W	R 88M-G40030H-S2	R 88M-G40030H-BS2
Three-phase 240 VAC	R7D-BP01H	50 W	R 88M-G05030H-S2	R 88M-G05030H-BS2
		100 W	R 88M-G10030H-S2	R 88M-G10030H-BS2
	R 7D-BP02H	200 W	R 88M-G20030H-S2	R 88M-G20030H-BS2
	R 7D-BP04H	400 W	R 88M-G40030H-S2	R 88M-G40030H-BS2

Flat Servomotor

Servomotors Combinations

Voltage	Servo Drive	Rated output	Servomotor	
	Pulse-train input		Without brake	With brake
Single-phase 120VAC	R 7D-BP01L	100 W	R 88M-GP10030L-S2	R 88M-GP10030L-BS2
	R 7D-BP02L	200 W	R 88M-GP20030L-S2	R 88M-GP20030L-BS2
Single-phase 240 VAC	R 7D-BP01H	100 W	R 88M-GP10030H-S2	R 88M-GP10030H-BS2
	R 7D-BP02HH	200 W	R 88M-GP20030H-S2	R 88M-GP20030H-BS2
	R 7D-BP04H	400 W	R 88M-GP40030H-S2	R 88M-GP40030H-BS2
Three-phase 240 VAC	R 7D-BP01H	100 W	R 88M-GP10030H-S2	R 88M-GP10030H-BS2
	R 7D-BP02H	200 W	R 88M-GP20030H-S2	R 88M-GP20030H-BS2
	R 7D-BP04H	400 W	R 88M-GP40030H-S2	R 88M-GP40030H-BS2

Accessories and Cables

CN1 Control Cables for CP1H/CP1L or general purpose controllers

Specifications	Model	
Connector-Terminal Block Cables	1 m	XW2Z-100J-B28
	2 m	XW2Z-200J-B28
General-purpose Control Cables	1 m	R7A-CPB001S
	2 m	R7A-CPB002S

Encoder Cables (for CN2) *1

Specifications	Model	
Standard Cables (connectors attached)	3 m	R88A-CRGB003C
	5 m	R88A-CRGB005C
	10 m	R88A-CRGB010C
	15 m	R88A-CRGB015C
	20 m	R88A-CRGB020C

Servomotor Power Cables (for CNB) *1

Specifications	Model	
Standard Cables (connectors attached)	3 m	R7A-CAB003S
	5 m	R7A-CAB005S
	10 m	R7A-CAB010S
	15 m	R7A-CAB015S
	20 m	R7A-CAB020S

Brake Cables

Specifications	Model	
Standard Cables	3 m	R88A-CAGA003B
	5 m	R88A-CAGA005B
	10 m	R88A-CAGA010B
	15 m	R88A-CAGA015B
	20 m	R88A-CAGA020B

Connectors

Specifications	Model
Main Circuit Connector (CNA)	R7A-CNB01P
Servomotor Connector (CNB)	R7A-CNB01A
Control Input Connector (CN1)	R88A-CNW01C
Encoder Input Connector (CN2)	R88A-CNW01R
Servomotor Connector for Encoder Cable	R88A-CNG02R
Servomotor Connector for Servomotor Power Cable	R88A-CNG01A

Power Supply Cables (For CNA)

Specifications	Model	
Power Supply Input Cable for Single-Phase Power (connectors attached)	2 m	R7A-CLB002S2
Power Supply Input Cable for Three-Phase Power (connectors attached)	2 m	R7A-CLB002S3
External Regenerative Resistor Connection Cable	2 m	R7A-CLB002RG

Personal Computer Monitor Cable

Specifications	Model	
Personal Computer Monitor Cable	2 m	R88A-CCG002P2

*1: For high flex cables add an "R" at the end of the part number.

Terminal Blocks for CP1H/CP1L or general purpose controllers

Specifications	Model
With M3 screws	XW2B-34G4
With M3.5 screws	XW2B-34G5
With M3 screws	XW2D-34G6

External Regeneration Resistors

Specifications	Model
220 W, 47 Ω	R88A-RR22047S
80 W, 100 Ω	R88A-RR080100S
80 W, 50 Ω	R88A-RR08050S

Reactors

Specifications	Applicable Servo Drive	Model
Single-phase 120 V	R7D-BPA5L	3G3AX-DL2002
	R7D-BP01L	3G3AX-DL2004
	R7D-BP02L	3G3AX-DL2007
Single-phase 240 V	R7D-BP01H	3G3AX-DL2004
	R7D-BP02HH	3G3AX-DL2004
	R7D-BP04H	3G3AX-DL2007
	Three-phase 240 V	R7D-BP01H
R7D-BP02H		3G3AX-AL2025
R7D-BP04H		3G3AX-AL2025

DIN Rail Mounting Unit

Specifications	Model
DIN Rail Mounting Unit	R7A-DIN01B

Parameter Unit

Specifications	Model
Parameter Unit	R88A-PR02G

Servo Drive Nomenclature

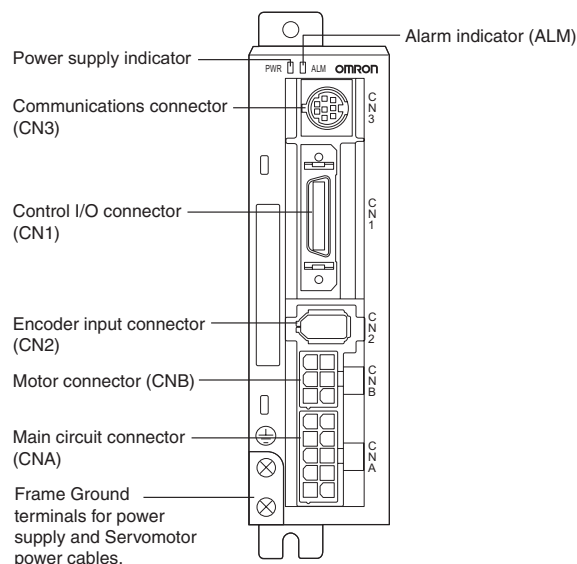

Servo Terminal block (Relay Units) and Cables

Select the Servo Terminal block and Cable according to the model number of the Position Control Unit being used.

Position Control Unit	Position Control Unit Cable	Servo Terminal block (Relay Unit)	Servo Drive Cable ¹	
CJ1W-NC133	XW2Z-050J-A18 XW2Z-100J-A18	XW2B-20J6-1B	XW2Z-100J-B29 XW2Z-200J-B29	
CJ1W-NC233 CJ1W-NC433	XW2Z-050J-A19 XW2Z-100J-A19	XW2B-40J6-2B		
CS1W-NC133	XW2Z-050J-A10 XW2Z-100J-A10	XW2B-20J6-1B		
CS1W-NC233 CS1W-NC433	XW2Z-050J-A11 XW2Z-100J-A11	XW2B-40J6-2B		
CJ1W-NC113	XW2Z-050J-A14 XW2Z-100J-A14	XW2B-20J6-1B		
CJ1W-NC213 CJ1W-NC413	XW2Z-050J-A15 XW2Z-100J-A15	XW2B-40J6-2B		
CS1W-NC113 C200HW-NC113	XW2Z-050J-A6 XW2Z-100J-A6	XW2B-20J6-1B		
CS1W-NC213 CS1W-NC413 C200HW-NC213 C200HW-NC413	XW2Z-050J-A7 XW2Z-100J-A7	XW2B-40J6-2B		
CJ1M-CPU21 CJ1M-CPU22 CJ1M-CPU23	XW2Z-050J-A33 XW2Z-100J-A33	XW2B-20J6-8A XW2B-40J6-9A (for 2 axes)		XW2Z-100J-B32 XW2Z-200J-B32
QCM1H-PLB21	XW2Z-050J-A3 XW2Z-100J-A3	XW2B-20J6-3B		XW2Z-100J-B29 XW2Z-200J-B29

Note: 1. Two Servo Drive Cables are required if 2-axis control is performed.

Note: Cable Length

050 = 0.5 m
100 = 1 m
200 = 2 m

Characteristics

120 VAC specification

Item	Servo Drive model		
	R7D-BPA5L	R7D-BP01L	R7D-BP02L
Continuous output current (rms)	1.0 A	1.6 A	2.5 A
Momentary maximum output current (rms)	3.3 A	5.1 A	7.5 A
Power supply capacity	0.16 KVA	0.25 KVA	0.42 KVA
Input power supply voltage (main circuit)	Single-phase 120 VAC (85 to 127 V), 50/60 Hz		
Input power supply current (rms) (main circuit)	1.4 A	2.2 A	3.7 A
Heat generated (main circuit)	12 W	16 W	22 W
Control method	All-digital servo		
Inverter method	IGBT-driven PWM method		
PWM frequency	12 kHz		6 kHz
Maximum response frequency (command pulses)	Line drive: 500 kpps, Open collector: 200 kpps		
Weight	0.35 kg		0.42 kg
Applicable motor capacity	50 W	100 W	200 W

240 VAC specification

Item	Servo Drive model			
	R7D-BP01H	R7D-BP02HH	R7D-BP02H	R7D-BP04H
Continuous output current (rms)	1.0 A	1.6 A	1.6 A	2.5 A
Momentary maximum output current (rms)	3.3 A	4.9 A	4.9 A	7.8 A
Power supply capacity	0.27 KVA (0.30 KVA) See note	(0.35 KVA) See note	0.42 KVA	0.69 KVA (0.77 KVA) See note
Input power supply voltage (main circuit)	Both single-phase and three-phase 200 to 240 VAC (170 to 264 V), 50/60 Hz			
Input power supply current (rms) (main circuit)	0.7 A (1.5 A) See note	(1.6 A) See note	1.1 A	1.8 A (3.5 A) See note
Heat generated (main circuit)	14 W	16 W	20 W	26W
Control method	All-digital servo			
Inverter method	IGBT-driven PWM method			
PWM frequency	12 kHz		6 kHz	
Maximum response frequency (command pulses)	Line drive: 500 kpps, Open collector: 200 kpps			
Weight	0.35 kg		0.42 kg	
Applicable motor capacity	100 W	200 W	200 W	400 W

Note: Values inside parentheses () are for single-phase 240-V use.

3,000-r/min Cylindrical Servomotors

120 VAC specification

Item	Unit	R88M-G05030H-S2	R88M-G10030L-S2	R88M-G20030L-S2
Rated output ^{*1}	W	50	100	200
Rated torque ^{*1}	N·m	0.16	0.32	0.64
Rated rotation speed	r/min	3000		
Max. rotation speed	r/min	5000		
Max. momentary torque ^{*1}	N·m	0.48	0.95	1.78
Rated current ^{*1}	A (rms)	1.1	1.7	2.5
Max. momentary current ^{*1}	A (rms)	3.4	5.1	7.6
Rotor inertia	kg·m ²	2.5 × 10 ⁻⁶	5.1 × 10 ⁻⁶	1.4 × 10 ⁻⁵
Applicable load inertia	---	30 times rotor inertia max.		

*1. These are the values when the Servomotor is combined with a Servo Drive at room temperature.
The momentary maximum torque shown above indicates the standard value.

3,000-r/min Cylindrical Servomotors

240 VAC specification

Item	Unit	R88M-G05030H-S2	R88M-G10030H-S2	R88M-G20030H-S2	R88M-G40030H-S2
Rated output ^{*1}	W	50	100	200	400
Rated torque ^{*1}	N·m	0.16	0.32	0.64	1.3
Rated rotation speed	r/min	3000			
Max. rotation speed	r/min	5000			
Max. momentary torque ^{*1}	N·m	0.48	0.95	1.78	3.60
Rated current ^{*1}	A (rms)	1.1	1.1	1.6	2.6
Max. momentary current ^{*1}	A (rms)	3.4	3.4	4.9	7.9
Rotor inertia	kg·m ²	2.5 × 10 ⁻⁶	5.1 × 10 ⁻⁶	1.4 × 10 ⁻⁵	2.6 × 10 ⁻⁵
Applicable load inertia	---	30 times rotor inertia max.			

* 1. These are the values when the Servomotor is combined with a Servo Drive at room temperature.
The momentary maximum torque shown above indicates the standard value.

3,000-r/min Flat Servomotors

120 VAC specification

Item	Unit	R88M-GP10030L-S2	R88M-GP20030L-S2
Rated output ^{*1}	W	100	200
Rated torque ^{*1}	N·m	0.32	0.64
Rated rotation speed	r/min	3000	
Max. rotation speed	r/min	5000	
Max. momentary torque ^{*1}	N·m	0.85	1.86
Rated current ^{*1}	A (rms)	1.6	2.5
Max. momentary current ^{*1}	A (0-p)	6.9	10.5
Rotor inertia	kg·m ²	9.0 × 10 ⁻⁶	3.4 × 10 ⁻⁵
Applicable load inertia	---	20 times rotor inertia max.	

*1. These are the values when the Servomotor is combined with a Servo Drive at room temperature.
The momentary maximum torque shown above indicates the standard value.

3,000-r/min Flat Servomotors

240 VAC specification

Item	Unit	R88M-GP10030H-S2	R88M-GP20030H-S2	R88M-GP40030H-S2
Rated output ^{*1}	W	100	200	400
Rated torque ^{*1}	N·m	0.32	0.64	1.3
Rated rotation speed	r/min	3000		
Max. rotation speed	r/min	5000		
Max. momentary torque ^{*1}	N·m	0.90	1.82	3.60
Rated current ^{*1}	A (rms)	1.0	1.6	4.4
Max. momentary current ^{*1}	A (0-p)	4.3	6.8	18.6
Rotor inertia	kg·m ²	9.0 × 10 ⁻⁶	3.4 × 10 ⁻⁵	6.4 × 10 ⁻⁵
Applicable load inertia	---	20 times rotor inertia max.		

*1. These are the values when the Servomotor is combined with a Servo Drive at room temperature.
The momentary maximum torque shown above indicates the standard value.



OMRON ELECTRONICS LLC • THE AMERICAS HEADQUARTERS • Schaumburg, IL USA • 847.843.7900 • 800.556.6766 • www.omron247.com

OMRON CANADA, INC. • HEAD OFFICE

Toronto, ON, Canada • 416.286.6465 • 866.986.6766 • www.omron.ca

OMRON ELETRÔNICA DO BRASIL LTDA • HEAD OFFICE

São Paulo, SP, Brasil • 55.11.2101.6300 • www.omron.com.br

OMRON ELECTRONICS MEXICO SA DE CV • HEAD OFFICE

Apodaca, N.L. • 52.811.156.99.10 • 001.800.556.6766 • mela@omron.com