

Broad Slot-type Photomicrosensor EE-SPX303/403

Long sensing distance (13 mm) without external light interference.

- Easy adjustment and optical axis monitoring with a light indicator.
- Connection possible with Programmable Controllers (PLCs).
- Easy-to-wire connector assures ease of maintenance.
- Wide operating voltage range: 12 to 24 VDC





 Refer to *Precautions* on page 53.

Ordering Information

List of Models

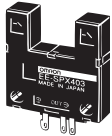
 Infrared light

Appearance	Sensing method	Sensing distance (slot width)		Output type	Output configuration	Model
	Through-beam type (with slot)		13 mm (slot width)	NPN output	Dark-ON	EE-SPX303
					Light-ON	EE-SPX403

Accessories (Order Separately)

Type	Cable length	Model	
Connector		EE-1001	
		EE-1009	
	Connector with Cable	1 m	EE-1006
			EE-1010
		2 m	EE-1006
			EE-1010
	Connector with Robot Cable	1 m	EE-1010-R
		2 m	EE-1010-R
NPN/PNP Conversion Connector	0.46 m (total length)	EE-2002	

Refer to *Accessories* on page 97 for details.

Ratings/Characteristics

Item	Models	EE-SPX303, EE-SPX403
Sensing distance		13 mm (slot width)
Sensing object		Opaque: 2.2 × 0.5 mm min.
Differential distance		0.05 mm max.
Light source		GaAs infrared LED (pulse lighting) with a peak wavelength of 940 nm
Indicator *1		Light indicator (red)
Supply voltage		12 to 24 VDC ±10%, ripple (p-p): 5% max.
Current consumption		Average: 15 mA max., Peak: 50 mA max.
Control output		NPN voltage output: Load power supply voltage: 12 to 24 VDC Load current: 80 mA max. 80 mA load current with a residual voltage of 1.0 V max. 10 mA load current with a residual voltage of 0.4 V max.
Response frequency *2		100 Hz min.
Ambient illumination		3,000 lx max. with incandescent light or sunlight on the surface of the receiver.
Ambient temperature		Operating: -10 to +55°C Storage: -25 to +65°C
Ambient humidity		Operating: 5% to 85% Storage: 5% to 95%
Vibration resistance		Destruction: 10 to 55 Hz, 1.5-mm double amplitude for 2 h each in X, Y, and Z directions
Shock resistance		Destruction: 500 m/s ² for 3 times each in X, Y, and Z directions
Enclosure rating		IEC IP50
Connecting method		Special connector (soldering not possible)
Weight		Approx. 3 g
Material		Polycarbonate

- *1. The indicator is a GaP red LED (peak emission wavelength: 700 nm).
- *2. The response frequency was measured by detecting the following rotating disk.

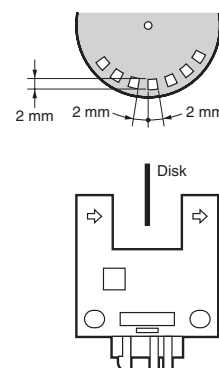

Engineering Data

Sensing Position Characteristics (Typical)

EE-SPX303

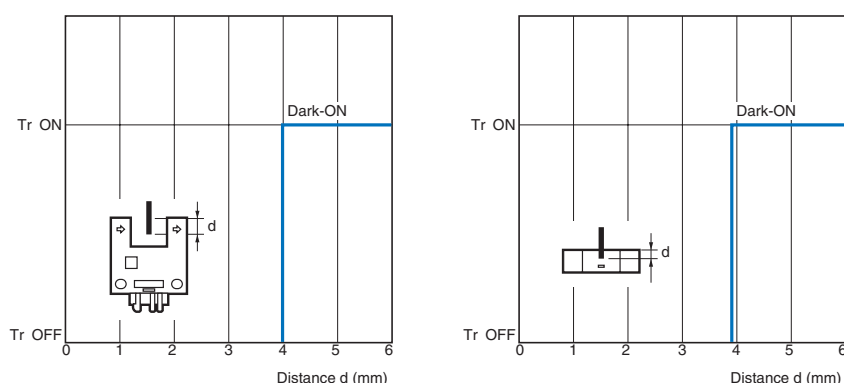

I/O Circuits

NPN Output

Model	Output configuration	Timing charts	Output circuit
EE-SPX403	Light-ON		<p>* Voltage output (when the sensor is connected to a transistor circuit)</p>
EE-SPX303	Dark-ON		

Precautions

Refer to *General Precautions* on page 23 to 28 for general precautions.

Warning

Do not use this product in sensing devices designed to provide human safety.



Precautions for Correct Use

Make sure that this product is used within the rated ambient environment conditions.

Wiring

- Connection is made using a connector. Do not solder to the pins (leads). The pins (leads) are soldered to the internal board of the Sensor. Therefore, direct soldering of the pins (leads) may result in an internal disconnection causing malfunction.

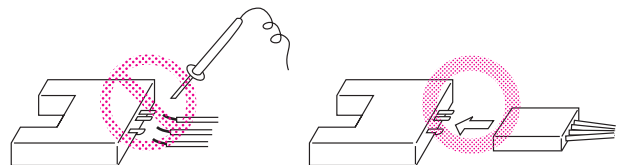

- When extending the cable, use an extension cable with conductors having a total cross-section area of 0.3 mm². The total cable length must be 2 m maximum.
- To use a cable length longer than 2 m, attach a capacitor with a capacitance of approximately 10 μF to the wires as shown below. The distance between the terminal and the capacitor must be within 2 m. (Use a capacitor with a dielectric strength that is at least twice the Sensor's power supply voltage.)

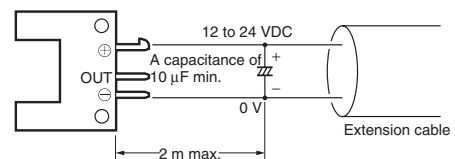

Dimensions (Unit: mm)

EE-SPX303, EE-SPX403

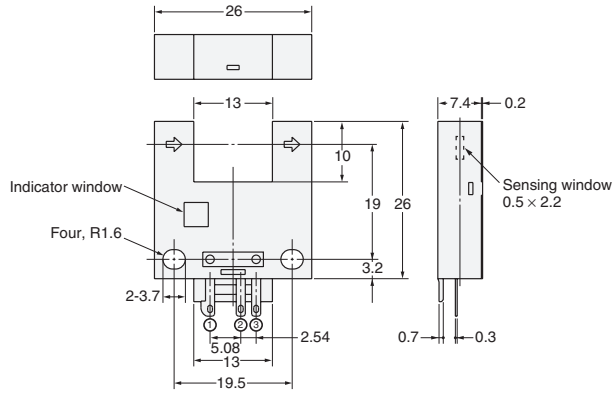
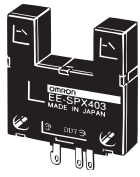

Terminal Arrangement

(1)	+	Vcc
(2)	OUT	OUTPUT
(3)	-	GND (0 V)

Accessories (Order Separately)

Refer to *Connectors* on page 97 for details on connectors.