

TGH600 Series

600 Watt Thick Film SOT227 Package



Due to the TGH600's non-inductive design, they are ideally suited for high-frequency and pulse-load applications. The TGH600 series resistors are designed for direct mounting onto a heatsink and provides up to 600 watts of power dissipation. Popular applications include variable speed drives, power supplies, control devices, telecom, robotics, motor controls, and other switching designs.



CHARACTERISTICS

Ohmic range	0.25 to 1K
Resistance tolerance	±10%; ±5% on request
Temperature coefficient	±250ppm/°C (others on request)
Maximum working voltage	1000V DC (higher voltage on request)
Power rating	600W at 85°C bottom case temperature. Note: Liquid cooling required to achieve full power rating.
Electric strength voltage	Dielectric strength up to 4,000VDC against ground
Isolation voltage	between R1 and R2: 500V; 1,000V on request
Partial discharge	2kVrms, <80pC
Insulation resistance	10GΩ min. at 1kV
Short time overload	1.25 x rated power at 85°C bottom case temp. for 10 sec, ΔR = 0.4% max.
Operating temperature	-55°C to +155°C
Mtg. torque for base plate	(static) 1.3 Nm to 1.5 Nm M4 screws
Mtg. torque for contacts	(static) 1.1 Nm to 1.3 Nm M4 screws, screw-in depth max. 5mm

Derating

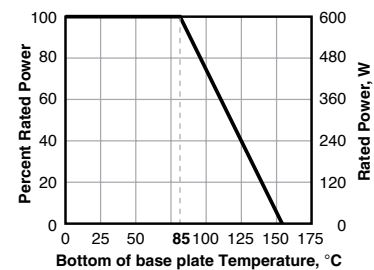

Derating (thermal resistance): 8.33 W/K (0.12 K/W) (for conf. 1, 2, 3) Best results can be obtained by using a thermal transfer compound with a heat conductivity of at least 2.9 W/mK. The flatness of the cooling plate must be better than 0.05 mm overall. Surface roughness should not exceed 6.4 μm.

PERFORMANCE DATA

Test	Method	ΔR
Moisture Resistance	MIL-Std-202, Method 106	(0.5% + 0.001W) max
Thermal shock	Mil-Std-202, Method 107, Cond F	(0.3% + 0.01W) max
Terminal Strength	MIL-Std-202, Method 211, Cond A (pull test) 2.4N	(0.2% = 0.01W) max
Vibration, High Frequency	MIL-Std-202, Method 204, Cond D	(0.2% + 0.01W) max
Life	20 years (120,000 hours) Operating failure rate of 8.3 x 10 ⁻⁷ fail/hour.	

Requirements to be achieved under the following conditions: T_{amb}=25°C, T_{HS}=70°C, P_{applied}=P_n

(continued)

TGH600 Series

600 Watt Thick Film SOT227 Package

DIMENSIONS

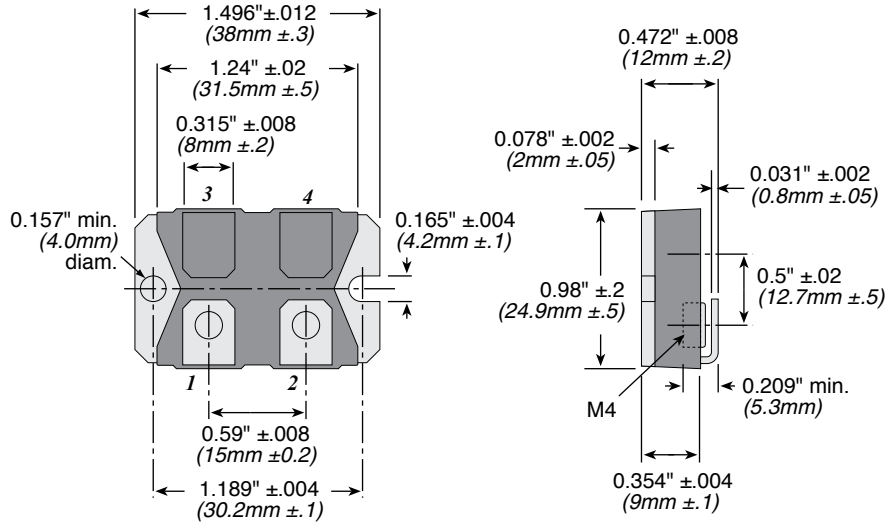

ORDERING INFORMATION

Configuration		E = RoHS compliant	
T G H P V 5 0 R 0 K E			
SOT227 Series	Wattage P = 600W	Resistance Value Example: R500 = 0.500Ω 1R00 = 1Ω 250R = 250Ω 1K00 = 1,000Ω 10K0 = 10,000Ω	Tolerance J = 5% K = 10%

Standard part numbers

TGHPVR500KE	TGHPV68R0KE
TGHPV1R00KE	TGHPV100RKE
TGHPV5R00KE	TGHPV150RKE
TGHPV7R50KE	TGHPV250RKE
TGHPV10R0KE	TGHPV470RKE
TGHPV15R0KE	TGHPV750RKE
TGHPV27R0KE	TGHPV1K00KE
TGHPV50R0KE	

THIS PRODUCT IS DESIGNED FOR USE WITH PROPER HEATSINKING.

Maximum base plate temperature of the resistor must be monitored and kept within specified limits to establish the power rating. Best technique is to attach a thermocouple to the side of the base plate of the resistor. Temperature of plastic housing or heat sink cannot be used to establish rating of the resistor.