

TAP600 Series

600 Watt Heat Sinkable Planar



Ohmite's TAP600 delivers 600 watts of reliable power to a variety of power conditioning, power transmission, and power control applications. These resistors can be designed for liquid or air cooled heat sink systems. Applications include variable speed drives, power supplies, robotics, motor control, and other control devices.

FEATURES

- Dielectric Strength up to 12KV
- Special Design for Low Inductance and Capacitance Values
- Contacts allow for easy load connection with M5 screws (not included) available with M4 as special request. Thread depth 7mm
- Encapsulated with a special resin filled epoxy casing with a large creepage distance to mass, large air distance between terminals, and a high insulation resistance (CTI 600).
- Materials meet the requirements of UL94-V0



CHARACTERISTICS

Resistance Values	0.25Ω to 100KΩ
Resistance Tolerance	±10% Std., 5% available on request.
Temperature Coefficient	±150ppm/°C (others upon request)
Maximum Working Voltage	5,000V DC, higher voltage on request, not exceeding max. power
Power Rating	600W at 70°C heat sink temperature or 85°C bottom case temperature. This value is only valid by using a thermal conduction to the heat sink Rth -cs<0.025°C/W. The value can be reached by using thermal transfer compound with a heat conductivity of 1w/mk. The flatness of the cooling plate must be better than 0.05mm overall. The roughness of the surface should not exceed 6.4µm.
Dielectric Strength Voltage	7K Vrms, 50Hz, 1min standard; up to 12k Vrms available
Single Shot Voltage	Up to 12KV Normwave (1.5/50 µsec)
Insulation Resistance	10GΩ min. at 500V
Creeping Distance	42mm min.
Air Distance	14mm min.
Inductance	≤80nH
Capacitance/Mass	≤110pF
Capacitance/Parallel	≤40pF
Operation Temperature	-55°C to +150°C
Max. Torque for Contacts	2 Nm
Max. Torque for Mounting	1.8 Nm
Derating (thermal resist.)	8.33W/°C (0.12°C/W) element to case

Test	Method	Typical Results - ΔR
Short Time Overload	1000 W/10 Sec. @ 70°C	0.4%
Humidity Steady State	56 Days/40°C/ 95°C	0.25%
Temp. Cycling	-55/+125/5 Cycles	0.20%
Shock	40g/4,000 Times	0.25%
Vibrations	2 - 500Hz/10g	0.25%
Load Life 1,000 Cycles	Pn 30 min. ON/30 min. OFF	0.40%
Terminal Strength of Contacts	200N	0.05%

Derating

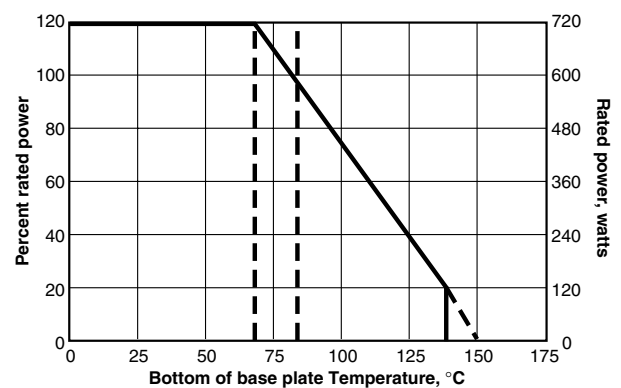

(continued)

TAP600 Series

600 Watt Heat Sinkable Planar

DIMENSIONS

(iin./mm)

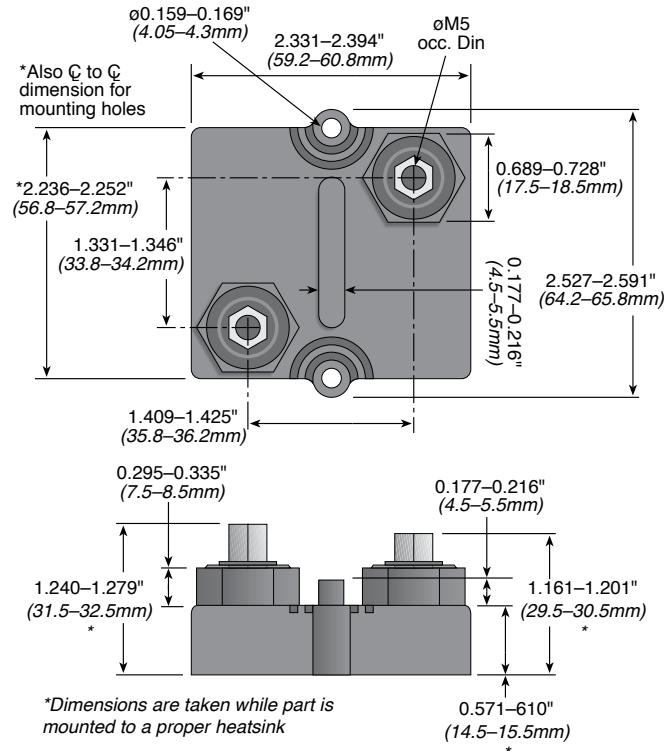

ORDERING INFORMATION

RoHS compliant
Non-compliant version
unavailable

TAP600K5R0E

Style	Tolerance	Resistance
	J = 5%	1 Ohm = 1R0
	K = 10%, Std.	10 Ohm = 10R
	L = 20%	1000 Ohm = 1K0

Standard Values

10% tol.

TAP600KR25E
TAP600KR33E
TAP600KR50E
TAP600K100E
TAP600K10KE
TAP600K10RE
TAP600K1K0E
TAP600K1R0E

TAP600K4R0E
TAP600K40RE
TAP600K20RE
TAP600K200E
TAP600K22RE
TAP600K2R0E
TAP600K3R0E
TAP600K50RE

TAP600K5R0E
TAP600K7K5E
TAP600K7R5E
TAP600K75RE
TAP600K750E
TAP600K30RE
TAP600K500E

5% tol.

TAP600J1R0E
TAP600J10RE
TAP600J50RE
TAP600J100E
TAP600J500E
TAP600J1K0E

THIS PRODUCT IS DESIGNED FOR USE WITH PROPER HEATSINKING.

Maximum base plate temperature of the resistor must be monitored and kept within specified limits to establish the power rating. Best technique is to attach a thermocouple to the side of the base plate of the resistor. Temperature of plastic housing or heat sink cannot be used to establish rating of the resistor.

The Ohmite CP4 (http://www.ohmite.com/cat/sink_cp4.pdf) is an example of properly designed heat sink.