

DESCRIPTION: FEMALE - 0.370 RIGHT ANGLE / MACHINED - ECONOMY

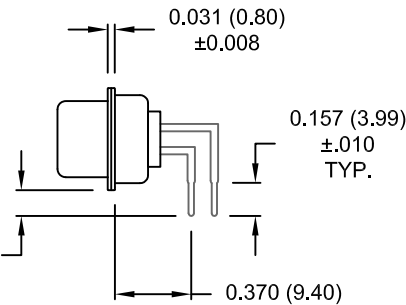
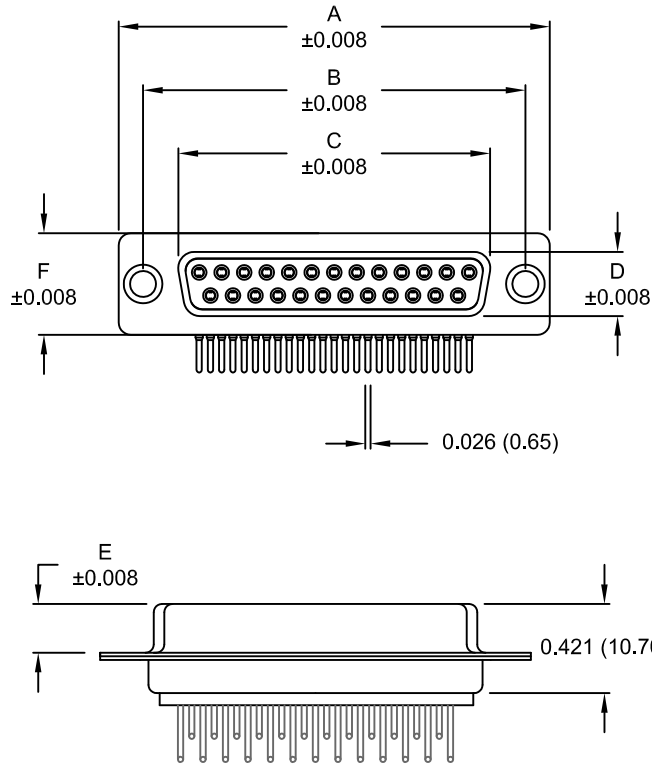

| DIMENSIONS (inch/mm) | | | | | | |
|----------------------|-------|-------|-------|-------|-------|-------|
| No. OF PINS | A | B | C | D | E | F |
| 9 | 1.213 | 0.984 | 0.642 | 0.311 | 0.228 | 0.492 |
| | 30.80 | 25.00 | 16.30 | 7.90 | 5.80 | 12.50 |
| 15 | 1.541 | 1.312 | 0.970 | 0.311 | 0.228 | 0.492 |
| | 39.20 | 33.30 | 24.60 | 7.90 | 5.80 | 12.50 |
| 25 | 2.089 | 1.852 | 1.512 | 0.311 | 0.228 | 0.492 |
| | 53.05 | 47.05 | 38.40 | 7.90 | 5.80 | 12.50 |
| 37 | 2.728 | 2.500 | 2.157 | 0.311 | 0.228 | 0.492 |
| | 69.40 | 63.50 | 54.80 | 7.90 | 5.80 | 12.50 |
| 50 | 2.638 | 2.402 | 2.055 | 0.429 | 0.236 | 0.602 |
| | 67.00 | 61.00 | 52.20 | 10.90 | 6.00 | 15.30 |

174-EYY-21YRYY1

SERIES _____
 POSITIONS _____
 E09 _____
 E15 _____
 E25 _____
 E37 _____
 E50 _____
 GENDER _____
 2 = FEMALE
 TERMINATION _____
 1 = PC MOUNTING
 SHELL PLATING _____
 3 = NICKEL
 RoHS COMPLIANT _____
 HARDWARE OPTIONS _____
 00 = NO HARDWARE
 01 = 0.098" CLINCH NUT (BOARD SIDE)
 14 = SHORT BRACKET WITH 4-40 SCREW LOCK
 24 = SHORT BRACKET WITH 4-40 SCREW
 46 = BRACKET WITH 4-40 INSERT AND BOARDLOCK
 PLATING OPTIONS _____
 1 = GOLD FLASH
 2 = 30MICRO-INCH GOLD
 3 = 50MICRO-INCH GOLD

MATERIAL:

SHELL: STEEL, NICKEL PLATED
 INSULATOR: UL 94V-O RATED, WHITE PA6T
 PROCESS TEMP.: 260° PROCESS TEMPERATURE
 CONTACT: PRECISION MACHINED COPPER ALLOY

ELECTRICAL:

CURRENT RATING: 5 AMPS
 CONTACT RESISTANCE: 10 mOhms Max.
 INSULATION RESISTANCE: 5 GOhms Min.
 VOLTAGE: 1000 V AC FOR 1 MINUTE
 TEMPERATURE: -55° C TO +125° C

UNITS = inch [mm]

DO NOT SCALE FROM DRAWING

RoHS COMPLIANT

| | | | |
|-------------------------|---|-----------------------|-------------------|
| | THESE DRAWINGS AND SPECIFICATIONS ARE THE PROPERTY OF NorComp AND SHALL NOT BE REPRODUCED, COPIED OR USED AS THE BASIS FOR THE MANUFACTURE OF SALE OF APPARATUS WITHOUT WRITTEN PERMISSION. | DRAWN: PAM JENKINS | DATE: 11-28-05 |
| | | SCALE: NTS | SHEET OF 1 3 |
| DWG NO. 174-EYY-21YRYY1 | | | |

DESCRIPTION: PCB LAYOUT

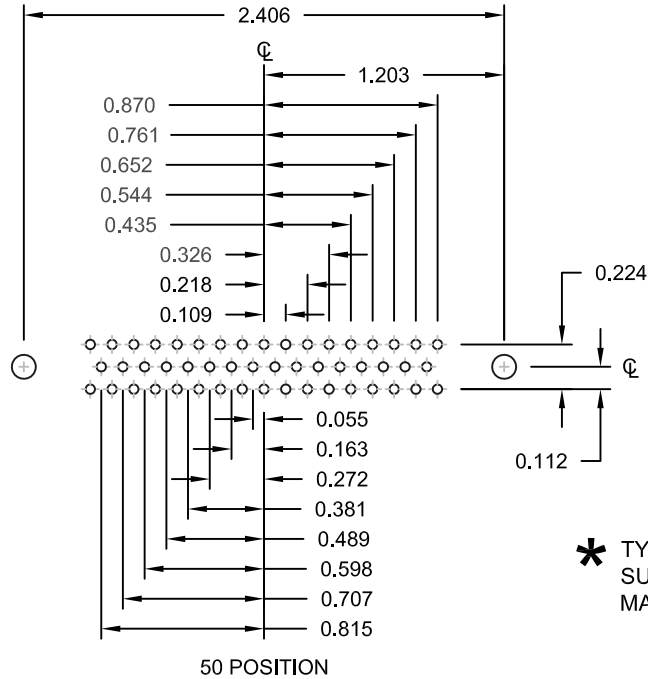
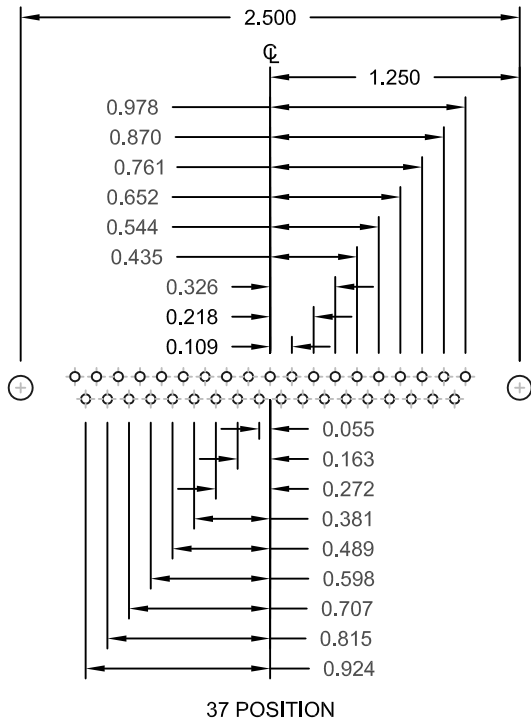
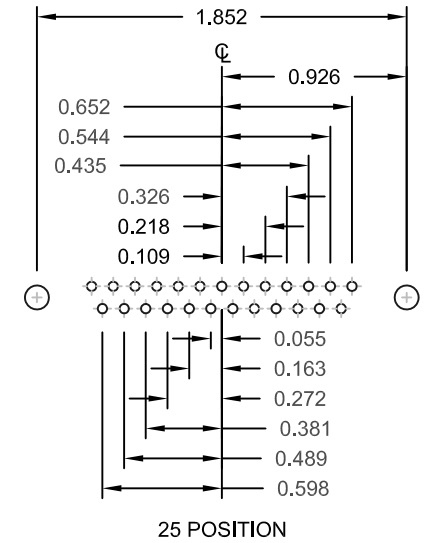
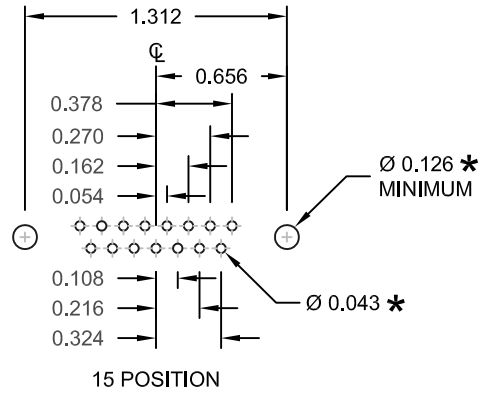
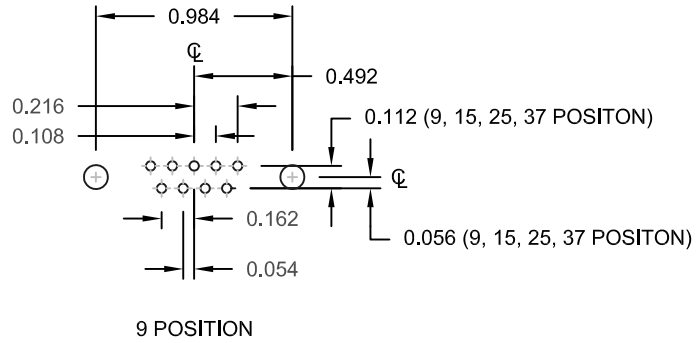

UNITS = inch

* TYP. SUGGESTED SIZE MAY NOT BE SUITABLE FOR ALL APPLICATIONS

DO NOT SCALE FROM DRAWING



THESE DRAWINGS AND SPECIFICATIONS ARE THE PROPERTY OF NorComp AND SHALL NOT BE REPRODUCED, COPIED OR USED AS THE BASIS FOR THE MANUFACTURE OF SALE OF APPARATUS WITHOUT WRITTEN PERMISSION.

| | | | |
|------------------------|------------|-------------------|-----------|
| DRAWN: PAM JENKINS | | DATE: 11-28-05 | |
| SCALE: NTS | SHEET 2 | OF 3 | REV 15 |
| DWG NO. 174-EYY-21YRY1 | | | |

NorComp

DESCRIPTION: HARDWARE

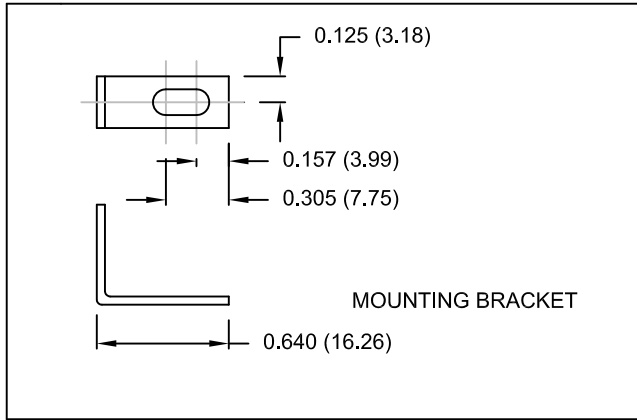

14Y = SHORT BRACKET & 4-40 FEMALE HEX SOCKET
 24Y = SHORT BRACKET & 4-40 SCREW

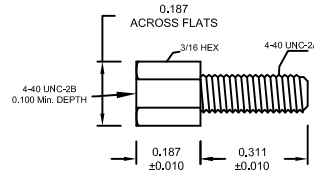

CLINCH-NUT HAS 4-40 INTERNAL THREADS

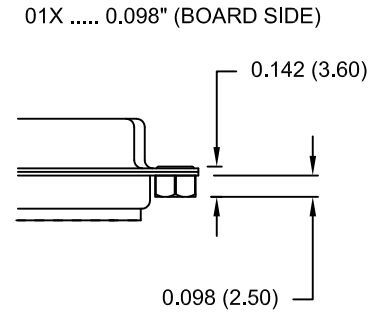

46Y = BRACKET WITH 4-40 INSERT AND BOARDLOCK

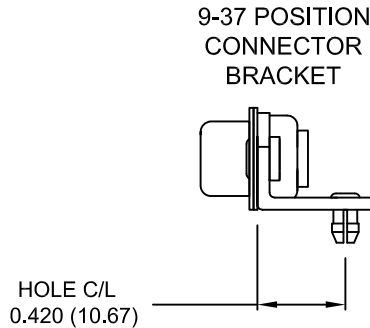

50 POSITION CONNECTOR BRACKET
 NOTE: LOCATOR PLATE PRESENT ON 50 PIN ONLY

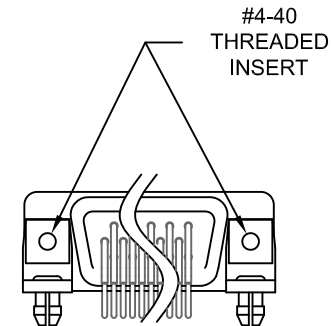
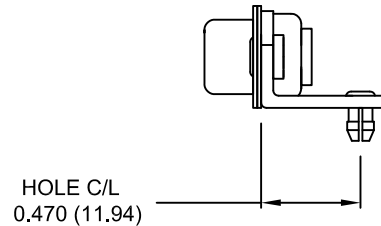

BRACKETS MOUNTED ON CONNECTOR

DO NOT SCALE FROM DRAWING

UNITS = inch [mm]



THESE DRAWINGS AND SPECIFICATIONS ARE THE PROPERTY OF NorComp AND SHALL NOT BE REPRODUCED, COPIED OR USED AS THE BASIS FOR THE MANUFACTURE OF SALE OF APPARATUS WITHOUT WRITTEN PERMISSION.

| | | | |
|------------------------|------------|-------------------|-----------|
| DRAWN: PAM JENKINS | | DATE: 11-28-05 | |
| SCALE: NTS | SHEET 3 | OF 3 | REV 15 |
| DWG NO. 174-EYY-21YRY1 | | | |

RoHS COMPLIANT

NorComp