

Skywire Global 4G LTE Cat M1, NB-IOT, 2G w/ GNSS Embedded Cellular Modem

Datasheet

NimbeLink Corp

Updated: May 2020



© NimbeLink Corp. 2020. All rights reserved.

NimbeLink Corp. provides this documentation in support of its products for the internal use of its current and prospective customers. The publication of this document does not create any other right or license in any party to use any content contained in or referred to in this document and any modification or redistribution of this document is not permitted.

While efforts are made to ensure accuracy, typographical and other errors may exist in this document. NimbeLink reserves the right to modify or discontinue its products and to modify this and any other product documentation at any time.

All NimbeLink products are sold subject to its published Terms and Conditions, subject to any separate terms agreed with its customers. No warranty of any type is extended by publication of this documentation, including, but not limited to, implied warranties of merchantability, fitness for a particular purpose and non-infringement.

NimbeLink is a registered trademark, and Skywire is a registered trademark, of NimbeLink Corp. All trademarks, service marks and similar designations referenced in this document are the property of their respective owners.

Table of Contents

Table of Contents	2
Introduction	4
Scope	4
Contact Information	4
Orderable Part Numbers	4
Additional Resources	4
Product Overview	5
Block Diagram	5
Technical Specifications	6
Electrical Specifications	6
Absolute Maximum Ratings	6
Typical Power Consumption	6
Module Pinout for Connectors J1 and J2	7
Module Pinout for Connectors J3, X1, X3	9
RF Specifications	9
Mechanical Specifications	10
Mechanical Characteristics	10
Mechanical Drawing	10
Mating Connectors	11
Device Placement	11
Environmental Specifications	11
Design Considerations	12
Power Supply Requirements	12
Power Supply Design Guidelines	13
Serial Communications	14
Serial UART Interface	14
USB Interface	14
VREF	14
Power Control	15
ON_OFF Signal	15
Power Monitoring	16
Shutdown	16
Firmware Updates Over the Air (FOTA)	16
Soldered-Down SIM	17
GNSS	17

GNSS Antenna Requirements	18
Active GNSS Antenna Control	18
GNSS Antenna Placement	19
Recommended Antennas	19
Cellular Antenna Requirements	20
Primary Antenna Requirements	20
Antenna Placement	21
Recommended Antennas	21
Skywire Reference Design	21
Mounting Guidelines	22
Board-to-Board Connectors Approach	22
Mechanical Retention	22
Solder to Board Connection	23
Regulatory information	23
Carrier Specific Certifications	23
Export Control Classification Number (ECCN)	23
RoHS Compliance	24
Interference statement	24
FCC & IC Compliance	24
Wireless Notice	25
Modification Statement	25
End Product Labeling Requirements	25
Document Version Information	26

1. Introduction

1.1 Scope

The aim of this document is to serve as a hardware reference datasheet for the NL-SW-LTE-QBG96 Skywire® modem family.

1.2 Contact Information

NimbeLink's goal is to make integrating the Skywire modem into your product as easy as possible. Please send any feedback, documentation requests, or technical support questions to Nimbelink's product support team at:

product.support@nimbelink.com

For purchasing information, please visit the "Part Ordering Information" section on the modem's [product page](#). Any additional sales questions or requests for quotation can be directed to NimbeLink's sales team at:

sales@nimbelink.com

1.3 Orderable Part Numbers

Orderable Device	Operating Temperature	4G LTE Bands	Fallback?	Applicable Networks
NL-SW-LTE-QBG96	-40 to +85°C	LTE-FDD: B1, B2 B3, B4, B5, B8, B12, B13, B18, B19, B20, B26, B28 LTE-TDD: B39 (LTE-M only)	2G GSM: GSM850, GSM900, DCS1800, PCS1900	AT&T, Orange, Telstra, Telus, Verizon, Vodafone, And more

1.4 Additional Resources

- [Skywire® Global 4G LTE Cat M1 Embedded Modem Product Page](#)
- [Skywire® Global 4G LTE Cat M1 AT Command Manual](#)
- [Skywire® Global 4G LTE Cat M1 Application Notes](#)
- [4G LTE Cat M1 Skywire NL-SWDK User Manual](#)
- [Skywire Hardware Design Developers Guide](#)
- [Skywire Hardware Design Checklist](#)
- [Skywire Software Developers Guide](#)

1.5 Product Overview

The Skywire® Global 4G LTE Cat M1 embedded modem is purpose-designed for IoT applications, particularly those requiring location-based functionality. Based on the Quectel BG96 module, it has full FCC, IC, and carrier end-device certifications, which can save users months of testing and tens of thousands of dollars in cost. Like all Skywire modems, the QBG96 is among the smallest embedded modems in the industry, and is compatible with a wide range of Skywire development kits and microprocessor shields, helping to accelerate product development and prototyping.

LTE Cat M1 modems have the lowest power requirements of any cellular modem type, making them ideal for battery operated, mobile, or off-grid applications. Depending on the application, they may be able to run for years unattended and without requiring a battery replacement or recharge.

1.6 Block Diagram

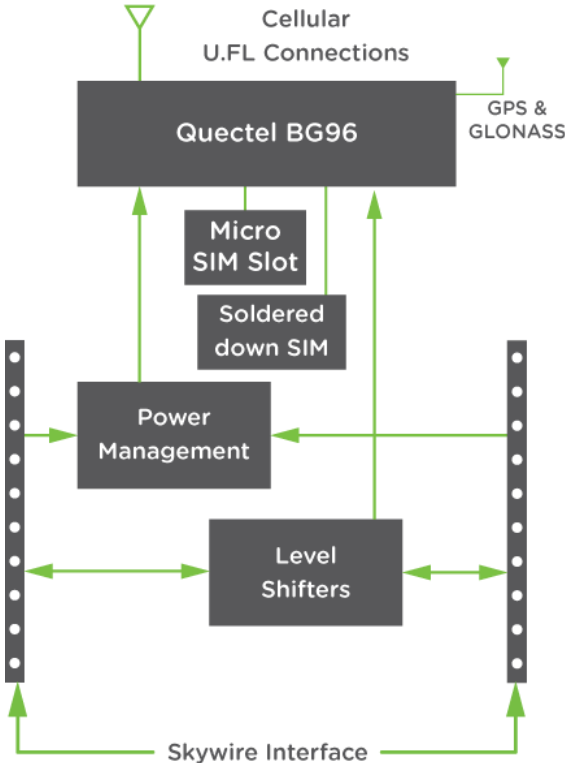

2. Technical Specifications

2.1 Electrical Specifications

2.1.1 Absolute Maximum Ratings

Parameter	Signal	Maximum Rating
Main Power Supply	VCC	4.3V
I/O Voltage Reference	VREF	5.5V

2.1.2 Typical Power Consumption

Mode	Signal Attenuation (dB)	RSRQ	RSRP	Average Current (mA)	Peak Current (mA)	Average Charge (μAh)	Measurement Notes
Active Socket Dial - Normal SIM	0	12	65	70.6492	339.977	408.524	Tested at 3.8V Time elapsed: 20.474s Test: Open socket, HTTP POST, read HTTP response, power off
Active Socket Dial - Normal SIM	20	13	50	71.184	359.832	414.546	Tested at 3.8V Time elapsed: 20.740s Test: Open socket, HTTP POST, read HTTP response, power off
Active Socket Dial - Normal SIM	40	13	26	75.193	625.849	435.851	Tested at 3.8V Time elapsed: 20.653s Test: Open socket, HTTP POST, read HTTP response, power off
Active Socket Dial - Integrated SIM	0	15	65	57.455	337.342	714.196	Tested at 3.8V Time elapsed: 44.720s Test: Open socket, HTTP POST, read HTTP response, power off
Active Socket Dial - Integrated SIM	20	15	50	58.314	409.365	734.491	Tested at 3.8V Time elapsed: 45.301s Test: Open socket, HTTP POST, read HTTP response, power off

Mode	Signal Attenuation (dB)	RSRQ	RSRP	Average Current (mA)	Peak Current (mA)	Average Charge (μAh)	Measurement Notes
Active Socket Dial - Integrated SIM	40	14	26	60.932	570.067	743.264	Tested at 3.8V Time elapsed: 43.868s Test: Open socket, HTTP POST, read HTTP response, power off
Off	0	12	64	6.474 (uA)	301.26 (uA)	551.336 (nAh)	Tested at 3.8V Issued AT+CFUN=0, AT+QPOWD, 5 minute sample
Idle	0	15	64	61.862	354.820	2817.362	Tested at 3.8V Powered on and registered on the network, 5 minute sample
PSM	0	16	65	12.310 (uA)	406.448 (uA)	286.584 (nAh)	Tested at 3.8V PSM State, 289s sample

2.1.3 Module Pinout for Connectors J1 and J2

The following table details the pinout of the NL-SW-LTE-QBG96 Skywire modem, and recommended ratings for the Skywire interface on connectors J1 and J2. Further details and design requirements for these pins are documented in Section 3.

Pin	Name	Direction	Description	Min	Typ.	Max	If not used	
1 (J1-1)	VCC	Input	Main Power supply	3.4V	3.8V	4.3V	Must be implemented	
2 (J1-2)	DOUT	Output	UART data out, I/O level tied to VREF	0V		VREF	Must be implemented if USB not used	
3 (J1-3)	DIN	Input	UART data in, I/O level tied to VREF	VREF Range		VIL	VIH	Must be implemented if USB not used
				1.65V to 1.95V	VREF x 0.35V	VREF x 0.65		
				2.3V to 2.7V	0.7V	1.7V		
				3.0V to 3.6V	0.8V	2V		
				4.5V to 5.5V	VREF x 0.3V	VREF x 0.7		
4 (J1-4)	GND	Input	Ground Pin		0V		Must be implemented	
5 (J1-5)	nRESET	Input	Reset signal for the Quectel BG96 module	VIL: GND to 0.5V		VIH: 1.3V to 2.1V	No connection	
6 (J1-6)	VUSB	Input	USB connection detection	3.0V	5.0V	5.25V	No connection	

Pin	Name	Direction	Description	Min	Typ.	Max	If not used	
7 (J1-7)	USB_P	I/O	USB differential data bus (+) Requires differential impedance of 90Ω.	Compliant with USB 2.0 standard specification.			No connection	
8 (J1-8)	USB_N	I/O	USB differential data bus (-) Requires differential impedance of 90Ω.	Compliant with USB 2.0 standard specification.			No connection	
9 (J1-9)	DTR	Input	Data terminal ready (sleep mode control), tied to internal reference voltage of 1.8V	VIL: GND to 0.45V		VIH: 1.35V to 5.5V	Tie to GND	
10 (J1-10)	GND	Input	Ground Pin		0V		Must be implemented	
11 (J2-1)	GND	Input	Ground Pin		0V		Must be implemented	
12 (J2-2)	CTS	Output	Clear to send	0V		VREF	No connection	
13 (J2-3)	STATUS	Output	Indicates the current operation status of the BG96 module. Driven high when the module is on.	0V		1.8V	No connection	
14 (J2-4)	VREF	Input	Voltage reference for offboard I/O signals.	0V	1.8V or 3.3V	5.5V	Must be implemented	
15 (J2-5)	GND	Input	Ground Pin		0V		Must be implemented	
16 (J2-6)	RTS	Input	Modem "Request to Send" hardware flow control input	VREF Range	VIL		VIH	No connection
				1.65V to 1.95V	VREF x 0.35V		VREF x 0.65	
				2.3V to 2.7V	0.7V		1.7V	
				3.0V to 3.6V	0.8V		2V	
				4.5V to 5.5V	VREF x 0.3V		VREF x 0.7	
17 (J2-7)	I2C SDA	I/O	I2C serial data. Used for external codec.	Pulled up to 1.8V internally			No connection	
18 (J2-8)	I2C SCL	I/O	I2C serial clock. Used for external codec.	Pulled up to 1.8V internally			No connection	
19 (J2-9)	RING	Output	Ring Indicator Output. Normally high, 120ms low pulse when URC present. Open Drain output, 1M pull-up on modem.	VOL 0 to 0.1V		VREF	No connection	
20 (J2-10)	ON_OFF	Input	Modem On/Off signal. See Section 3.5 for additional requirements.	1.3V ≤ VIH ≤ 2.1V 0V ≤ VIL ≤ 0.5V			Must be implemented.	

Additional information on the Skywires pinout is available in Section 3.

2.1.4 Module Pinout for Connectors J3, X1, X3

Connector Designator	Description	Connector Location
J3	Micro SIM Connector	Bottom Side of Modem
X1	Primary Cellular Antenna Connection	Top side of Modem
X3	GPS/GNSS Satellite Receiver	Top Side of Modem

2.2 RF Specifications

Parameter		Value	
4G LTE Technology		4G Cat M1, 4G Cat NB1	
4G LTE TX output power		23dBm ± 2dB	
4G LTE RX Sensitivity	Band	Cat M1/3GPP (dBm)	Cat NB1/3GPP (dBm)
	B1	-107.0/-102.7	-112.5/-107.5
	B2	-106.7/-100.3	-112.5/-107.5
	B3	-106.8/-99.3	-113/-107.5
	B4	-106.9/-102.3	-112.5/-107.5
	B5	-107.0/-100.8	-114/-107.5
	B8	-107.3/-99.8	-113/-107.5
	B12	-107.7/-99.3	-113.5/-107.5
	B13	-106.5/-99.3	-112/-107.5
	B18	-107.5/-102.3	-113.5/-107.5
	B19	-107.1/-102.3	-114/-107.5
	B20	-107.2/-99.8	-114/-107.5
	B26	TBD/-100.3	TBD/-107.5
	B28	-107.2/-100.8	-113/-107.5
B39	TBD /-103	Not Supported	
GSM RX Sensitivity	GSM850/GSM900	-109/-102	
	DCS1800/PCS1900	-108.5/-102	
Peak Uplink and Downlink Speeds	Connection Type	Downlink	Uplink
	4G LTE Cat M1	300 Kbps	375 Kbps
	4G Cat NB1	32 Kbps	70 Kbps
	GSM	296 Kbps	236.8 Kbps

2.3 Mechanical Specifications

2.3.1 Mechanical Characteristics

Parameter	Typical	Unit
Dimensions (excluding pin height, for solder to board applications)	29.0 x 33.60 x 6.63	mm
Dimensions (including pin height, for board to board connector applications)	29.0 x 33.60 x 10.73	mm
Weight	8	Grams
Connector Insertion/Removal	hundreds	Cycles

2.3.2 Mechanical Drawing

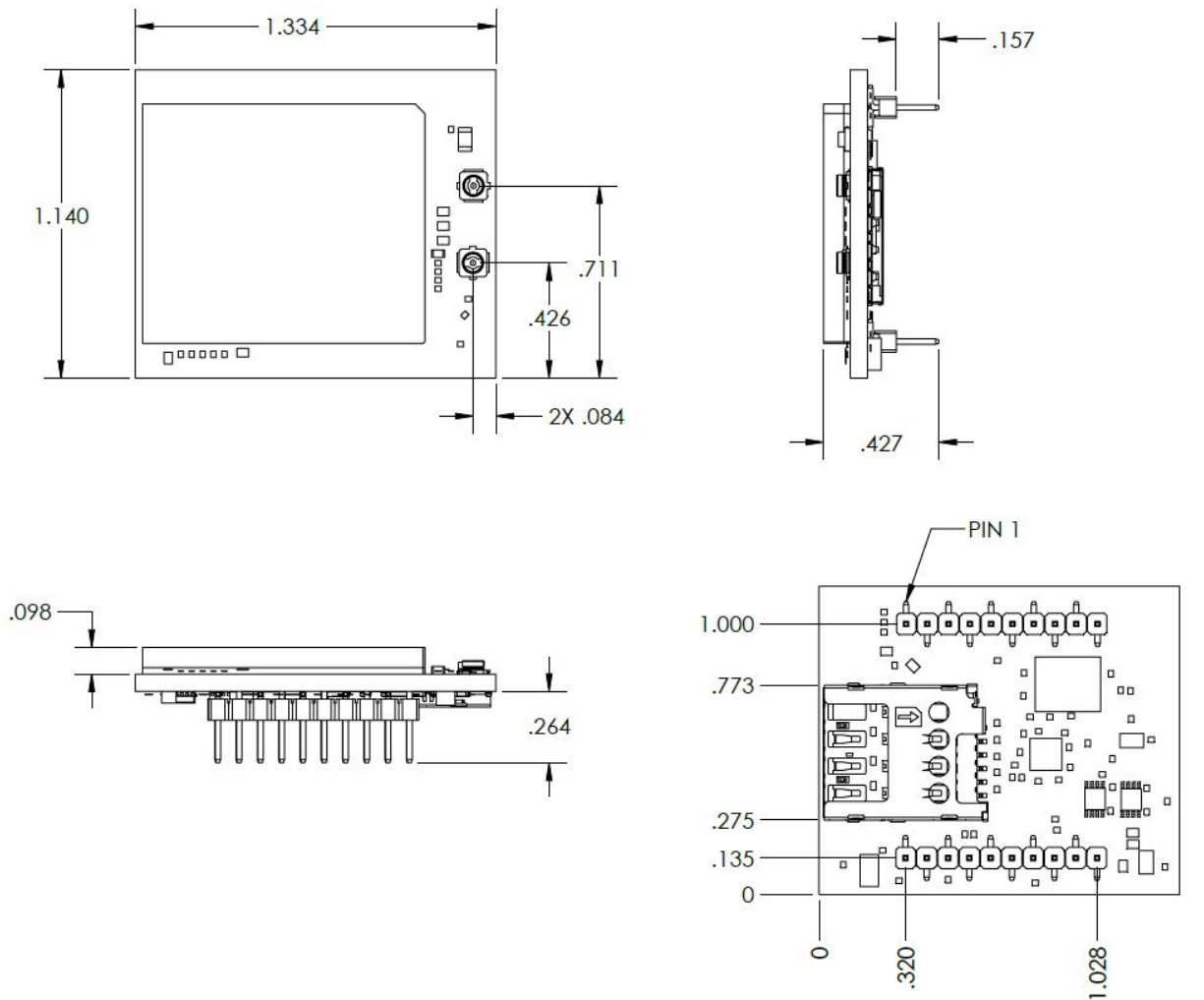

Units in mils.

2.3.3 Mating Connectors

Connector Designator	Manufacturer	Populated on Modem	Recommended Mate	Mate Manufacture
J1, J2	3M	951110-2530-AR-PR	950510-6102-AR	3M
			Acceptable alternate: NPPN101BFCN-RC	Sullins Connector Solutions
J3	Molex	786463001	Micro SIM 3FF Size	Micro SIM Card
X1, X3	Hirose	U.FL-R-SMT(10)	CAB.011	Taoglas

2.3.4 Device Placement

⚠ Make sure the Skywire is installed in the correct orientation in your host board. Failure to do so will damage the device and void the warranty.

2.3.5 Environmental Specifications

Parameter	Min	Typical	Max	Unit	Note
Operating Temperature	-40	25	+85	°C	
Storage Temperature	-40	25	+90	°C	
Operating Humidity	20		90	%	Non-condensing

3. Design Considerations

The following sections detail various design considerations that system designers should follow when designing the Skywire modem into their system. NimbeLink offers free schematic and layout design reviews for customers integrating a Skywire modem into their design. For more details please reach out to Nimbelink product support team at product.support@nimbelink.com.

3.1 Power Supply Requirements

NL-SW-LTE-QBG96 modems will regularly consume high amounts of current on its Main Power Supply (Pin 1, VCC) input, up to 1.2A during LTE-M1 transmits and receives, 2G GSM connections will repeatedly hit 2A during transmissions. In order to maintain compatibility with other 4G Skywire modems, the baseboard power supply should be designed to support peak currents of at least 2 Amps. A 0.1 uF & 100uF low ESR ceramic capacitor should be placed on the baseboard near the VCC pin of the Skywire to ensure ample energy is available, with a low inductance path to the VCC pin.

Parameter	Value
Nominal Supply Voltage	3.8V
Operating Voltage Range	3.40V to 4.30V
Extended Operating Voltage Range	3.30V to 4.50V

NL-SW-LTE-QBG96 modems have a normal operating voltage range of 3.40V to 4.30V, with a recommended input voltage of 3.80V. The modems also support an extended operating voltage range of 3.30V to 4.50V. The extended operating voltage range is the maximum/minimum range for voltage transients on the modems power line. Extreme care must be taken to ensure that the modem power supply stays within the extended operating voltage range.

If there is a voltage drop or overshoot that exceeds the limits of the extended operating voltage range, it may cause damage to the modem and void the modem's warranty. The extended operating voltage range should only be used with thoroughly tested power supply systems that have been shown to be able to handle the rigorous current demands of an LTE modem without falling out of the extended operating voltage range.

3.1.1 Power Supply Design Guidelines

When designing the power supply for a Skywire modem it is recommended to adhere to the following design guidelines:

- For most applications, a switching power supply is recommended to supply power to the Skywire modem. This is because switching power supplies are able to rapidly respond to the sudden current demands of an LTE modem. To ensure compatibility with other Skywire modems, it is recommended to use a switching regulator capable of supporting up to 2A. Example designs using a switching DC/DC regulator can be found in the reference schematics below.
- To reduce EMI from the switching regulator, it is important to follow the design guidelines from the device manufacturer.
- Bypass ceramic capacitors (low ESR) with adequate capacity must be placed near the input to pin 1 (VCC) of the Skywire modem. It is recommended that the capacitor have a rated voltage of at least 2x the input voltage to the Skywire. A minimum of a 100 uF & 0.1uF capacitor is recommended for all Skywire modems. The 0.1uF capacitor should be placed as close as possible to pin 1 of the Skywire modem, followed by the 100 μ F capacitor.
- The PCB traces from the power regulator and the bypass capacitors must be at least 80 mils to ensure that there is a low impedance power delivery circuit available to the modem. This ensures that no significant voltage drops occur. Try to keep the trace as short as possible.
- A dedicated ground plane is recommended.
- Power supply input cables should be kept away from noise sensitive lines, such as antennas.

NimbeLink offers multiple power supply reference designs in order to assist customers with their designs at no extra charge. Two of the designs are linked to below:

[NL-AB-BBCL Reference Schematic](#)

[NL-SWDK Reference Schematic](#)

Nimbelink highly recommends prototyping with a Skywire Development kit as opposed to a breadboard, which will not work with a Skywire modem. Please refer to the following application note, which explains this incompatibility in more detail:

[Prototyping with Cellular Modems and Modules](#)

3.2 Serial Communications

The NL-SW-LTE-QBG96 modem has two communication paths: serial (UART) and USB. The serial UART interface is targeted for applications using lower speed 8/16/32 bit microcontrollers that do not have a USB interface or easily available USB interface drivers. The USB interface for the modem is meant for use by higher end systems with a native USB interface controller or operating system (Single board computers, Linux/Windows).

For designs that are only using the serial UART interface, NimbeLink recommends designers include test points or a non-populated USB connector footprint in their designs. This allows access to the modem's USB interface to enable easy debugging and firmware updates.

3.2.1 Serial UART Interface

All Skywire modems support a serial UART interface with transmit and receive on pins 2 (DOUT) and 3 (DIN). On the NL-SW-LTE-QBG96 modem, the baud rate defaults to 115200 Baud 8N1. If a different baud rate is required, it can be changed with the **AT+IPR** command as defined in the AT command manual. The modem also supports RTS/CTS flow control on pins 12 (CTS) and 16 (RTS).

By default, the modem does have flow control enabled. To modify the flow control setting, please see the **AT+IFC** command in the AT command manual. It is recommended that any designs using the serial UART interface connect the RTS/CTS flow control lines to the host microcontroller and enable them in their application.

3.2.2 USB Interface

The NL-SW-LTE-QBG96 modem supports a USB 2.0 interface on pins 6 (VUSB), 7 (USB_P), and 8 (USB_N). Systems connecting to the modem's USB interface must observe proper design practices for connecting to a high speed USB device including, but not limited to, the following:

- The USB D± traces should be routed as a 90 ohm impedance differential pair.
- The USB D± traces should length matched.
- USB trace lengths should be minimized.
- USB differential pairs should be carefully routed to ensure they have a continuous return path beneath the traces. Do not route differential pairs over splits in ground or power planes.
- If the USB signals will be used off-board, ESD protection should be implemented near the off-board connector.

Pin 6 is the VUSB detection pin that the modem uses to detect if a USB host controller has been connected to the modem. This pin has an internal pulldown and must have a voltage between 3.0V and 5.5V applied to it in order to activate the USB interface. The VUSB pin will draw less than 5mA when connected. VUSB must be disconnected or asserted to ground before activating Power Saving Mode.

3.3 VREF

The VREF signal drives the input voltage side of an onboard buffer which converts external I/O voltage from the VREF range to the 1.8V range in order to drive the onboard Quectel BG96 module. System designers should connect the reference voltage of their system to this pin. The VREF signal will draw less than 1mA when the modem is powered.

To enable low power operation, system designers should include a method of removing the voltage from VREF when the system is in Power Save Mode (PSM). One such method would be to power VREF from a GPIO or to have a P-CH MOSFET in the VREF signal path.

3.4 nRESET Signal

In the event that the modem becomes unresponsive, pin 5 (nRESET) can be grounded to unconditionally shut down the modem. When pin 5 is grounded, the modem will cease all ongoing operations, and reset itself. Please note: the modem will not detach itself from the network before resetting.

Network providers request that a device gracefully detach from the network before shutting down. Accordingly, this functionality should only be used as an emergency reset when the modem is not responding to commands.

To unconditionally shut down the modem with the nRESET signal, tie the pin low for at least 150 ms, and then release. The signal is internally pulled up to the modem's internal 1.8V rail.

If the signal is unused, it can be left floating, but it is highly recommended that the signal be connected to the host system. If the signal is used, it should be driven with an open collector output from the host system or a discrete open collector transistor.

In high noise (high EMI) environments, we recommend designers place a 0.01-0.1 uF capacitor on the nRESET line near the J1 connector.

3.5 Power Control

3.5.1 ON_OFF Signal

The ON_OFF signal on pin 20 is used to trigger the modem to turn on, and to turn the modem off. Please note: do not power this pin nor apply a pullup resistor.

To conserve power, the onboard cellular module does not automatically startup when power is applied. Therefore, the baseboard design must supply a means to assert a logic-low level on the ON_OFF pin. To initiate the startup procedure, tie ON_OFF to ground for at least 100 ms. Similarly, if the modem is currently running, the ON_OFF pin can be pulled low for at least 650 ms to initiate a power-down sequence.

The ON_OFF signal should be driven with an open collector output or with an open collector transistor. The signal is internally pulled up and should not be driven high, as doing so may prevent the modem from booting.

3.5.2 Power Monitoring

Applications can check to see if the modem has powered up by reading the logic state on pin 13 (STATUS). When the Quectel BG96 module is powered up and running, pin 13 will be driven high to 1.8 V. When the module is not running, this pin will be grounded.

3.5.3 Shutdown

The modem should be shut down in a controlled manner, so as to gracefully disconnect it from the network. Failure to do so violates carrier requirements. In rare events, failure to properly shut down the modem could render the modem inoperable due to firmware corruption.

To gracefully shut down the modem, the host system should do the following:

- Shut down the modem with the **AT+QPOWD=1** command. This command will gracefully disconnect the modem from the network and shut down the modem. This process will take no longer than a couple of seconds. After this command is issued, the host system should cease any communications with the modem.
- If power is to be cut from the modem, ensure that the host system is not back powering the modem through any of the modem's I/O lines.
- Users should monitor the STATUS pin (as described in Section 3.5.2) to ensure the modem has powered down.
- Remove VREF (if VCC is being removed).
- Remove VCC.

In the event of power failure, the modem may need to be shut down faster than the **AT+QPOWD=1** command can manage. To immediately power down the modem in the event of power failure, the **AT+QPOWD=0** command can be used to force a fast shutdown.

3.6 Network Status Monitoring

In order to conserve power, the NL-SW-LTE-QBG96 does not have a status LED. It is recommended to monitor the modem's network status using AT commands and the serial interface.

3.7 Firmware Updates Over the Air (FOTA)

LTE networks are constantly being updated, improved, and enhanced with new features. As a result, carriers are making frequent network changes. Most will not negatively affect devices connected to those networks, but occasionally an update will prevent an unprepared device from reconnecting to the network permanently.

To account for these future changes, FOTA (Firmware over the Air) capability is being added to cellular modules by each manufacturer. Accordingly, NimbeLink supports this functionality in the entire Skywire family of embedded modems. As such, it is highly recommended that designers implement provisions to accommodate for FOTA processes.

Failure to accommodate FOTA processes may result in interruptions in cellular connectivity in the event of network changes. If a device can no longer access the network, FOTA cannot be used to remedy the problem. The only way to recover functionality is to physically update the device firmware.

FOTA Instructions are available by contacting NimbeLink's product support team at product.support@nimbelink.com.

3.8 Soldered-Down SIM

The NL-SW-LTE-QBG96 modem has the ability to select between a soldered-down SIM or a removable SIM inserted into the SIM card slot on the modem.

By default, the modem is configured to attempt to use the SIM card slot. However, users can select which SIM the modem is using by controlling the onboard SIM selection switch with AT commands. Whenever SIM selection is switched, the modem's RF system will need to be toggled with the AT+CFUN command.

To configure the modem to use the soldered down SIM issue the following commands to the modem in the order they appear below:

```
AT+CFUN=0
AT+QCFG="gpio",1,26,1,0,0,1
AT+QCFG="gpio",3,26,1,1
AT+CFUN=1
```

To configure the modem to use the SIM in the SIM card socket issue the following commands to the modem in the order they appear below:

```
AT+CFUN=0
AT+QCFG="gpio",1,26,1,0,0,1
AT+QCFG="gpio",3,26,0,1
AT+CFUN=1
```

Note: GPIO states will persist after reset, and the above AT commands will not need to be reissued each time the modem is powered on. Firmware updates may overwrite saved GPIO states, however.

3.9 GNSS

The onboard Quectel BG96 module includes a fully integrated global navigation satellite system solution that supports Gen8C-Lite of Qualcomm (GPS, GLONASS, BeiDou/Compass, Galileo and QZSS). The BG96 has an embedded low-noise amplifier (LNA) that is utilized by the GNSS system. The modem supports both passive GNSS antennas and active antennas with a gain, at the modems RF connector, of <20dB.

The requirements for the GNSS antenna are available in Section 3.9.1.

3.9.1 GNSS Antenna Requirements

Item	Value
Frequency Range	1559 – 1609 MHz
Impedance	50 Ω
Polarization	RHCP or linear
VSWR	< 2 (Typ.)
Passive Antenna Gain	> 0 dBi
Active Antenna Noise Figure	< 1.5 dB
Active Antenna Gain	> 0 dBi
Active Antenna Embedded LNA Gain	< 17 dB
GNSS Frequency	Frequency
GPS/Galileo/QZSS	1575.42 \pm 1.023 MHz
GLONASS	1597.5 – 1605.8 MHz
Galileo	1575.42 \pm 2.046 MHz
BeiDou	1561.098 \pm 2.046 MHz
QZSS	1575.42 MHz

3.9.2 Active GNSS Antenna Control

A 3.3VDC, 100 mA source is available on the modem to bias the GPS line in order to power the modem. Control of the GNSS power source is done via GPIO64 on the modem. To conserve power, the GNSS power is off by default.

To turn on the DC power to the GNSS antenna, and save it in this state across power off, issue the following commands to the modem:

```
AT+QCFG="gpio",1,64,1,0,0,1
```

```
AT+QCFG="gpio",3,64,1,1
```

To turn off the DC power to the GNSS antenna, and save this state after power off, issue the following commands to the modem:

```
AT+QCFG="gpio",1,64,1,0,0,1
```

```
AT+QCFG="gpio",3,64,0,1
```

Note: GPIO states will persist after reset, and the above AT commands will not need to be reissued each time the modem is powered on. Firmware updates may overwrite saved GPIO states, however.

3.9.3 GNSS Antenna Placement

- The antenna must be installed according to the antenna manufacturer's instructions in order to obtain the maximum performance of the GNSS receiver.
- The antenna location must be evaluated carefully if operating in conjunction with any other antenna or transmitter.
- The antenna must not be installed inside metal cases or near any obstacle that may degrade features like antenna lobes and gain.
- Keep the antenna and the antenna cabling away from any power supply lines, noisy EM devices, and wireless RF lines.

3.9.4 Recommended Antennas

Type	Manufacturer	Part Number
GPS/GALILEO Antenna, Internal ¹	Taoglas	AP.17E.07.0064A
GPS/GALILEO Antenna, External ¹	Taoglas	AA.108.301111

Note 1: U.FL to SMA adapter required.

3.10 Cellular Antenna Requirements

NL-SW-LTE-QBG96 modems support one primary cellular antenna connection for RX & TX communication via the X1 connector on the top of the modem. The X1 connector is a U.FL connector. Many antennas will require the use of a U.FL to SMA cable, such as the Taoglas CAB.011.

3.10.1 Primary Antenna Requirements

Depending on the frequency band(s) provided by the network operator, the customer shall use the most suitable antenna for that/those band(s):

Item		Value	
Frequency Range	Band	Uplink (MHz)	Downlink (MHz)
	B1	1920 – 1980	2110 – 2170
	B2, PCS1900	1850 – 1910	1930 – 1990
	B3, DCS1800	1710 – 1785	1805 – 1880
	B4	1710 – 1755	2110 – 2155
	B5, GSM850	824 – 849	869 – 894
	B8, EGSM900	880 – 915	925 – 960
	B12	699 – 716	729 – 746
	B13	777 – 787	746 – 756
	B18	815 – 830	860 – 875
	B19	830 – 845	875 – 890
	B20	832 – 862	791 – 821
	B26	814 – 849	859 – 894
	B28	703 – 748	758 – 803
	B39	1880 – 1920	1880 – 1920
VSWR		≤ 2 (Typ.)	
Efficiency		> 30%	
Max Input Power		50 W	
Input Impedance		50 Ω	
Cable Insertion Loss (LTE B5/B8/B12/B13/B18/B19/B20/B26/B28 GSM850/GSM900)		< 1 dB	
Cable Insertion Loss (LTE B1/B2/B3/B4/B39, DCS1800/PCS1900)		< 1.5 dB	

Note: Any antennas used with the modem will need to comply with the Wireless Notice detailed in Section 5.7.

3.10.2 Antenna Placement

The modem's cellular antenna placement will directly affect the modem's performance. It is vital that system designers carefully consider the placement of the antenna and follow all of the guidelines & specifications set by the antenna manufacturer. The following guidelines are general recommendations for antenna installation:

- Make sure the antenna has an impedance of 50 ohms.
- Keep the antenna cable as short as possible.
- The antenna must not be installed inside a metal enclosure, nor near metal objects unless specified by the antenna manufacturer.
- The antenna must be installed according to the manufacturer's instructions.
- Antenna gain must not exceed the values indicated in the regulatory requirements.
- Antenna integration should optimize antenna efficiency. Antennas are recommended to have >50% efficiency on all frequency bands.
- Additional FCC/IC testing may be required for applications where the antenna is located closer than 20 CM from the body.
- If the device antenna is located farther than 20cm from the human body and there are no co-located transmitter, the Quectel FCC/IC approvals can be re-used by the end product
- Antenna should not be mounted near noisy EM devices.

3.10.3 Recommended Antennas

Type	Manufacturer	Part Number
Internal Cellular Antenna	Taoglas	FXUB65.07.0180C
External Cellular Antenna ¹	Taoglas	TG.30.8113

Note 1: U.FL to SMA adapter required.

3.11 Skywire Reference Design

NimbeLink offers free reference schematic and layout files as examples of how to integrate Skywire modems into various systems. Schematics, design files, gerber files, and tutorials for a variety of different systems can be found on the [Skywire Development Tools webpage](#).

4. Mounting Guidelines

Skywire embedded cellular modems support multiple connection methods. The two primary methods are board-to-board connectors and soldering directly to the baseboard.

4.1 Board-to-Board Connectors Approach

The Skywire interface calls for two 10-pin, 2mm pitch, female receptacles spaced 22 mm apart. There are many connector manufacturers that can be used. Below is one readily available product:

Manufacturer: Sullins Connector Solutions, **Part Number:** NPPN101BFCN-RC

Typical part drawing and footprint information for the NPPN101BFCN-RC connector:

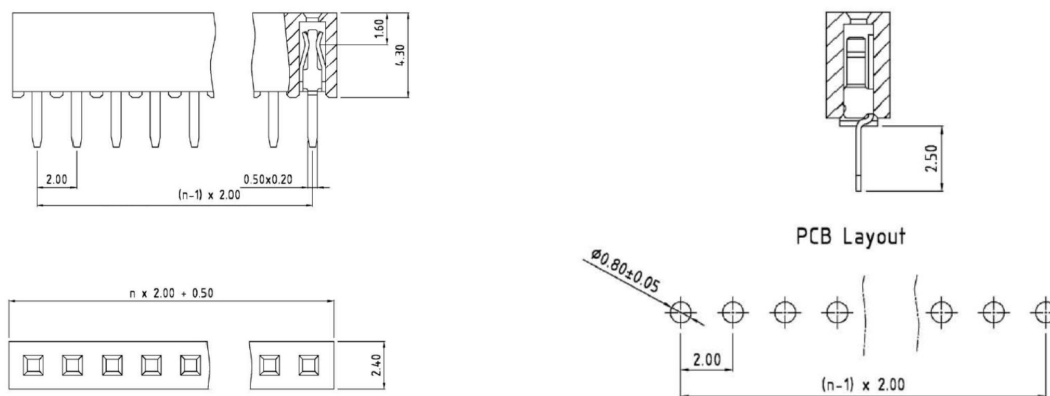

When using the recommended connector, ensure that any baseboard components placed under the Skywire (between the baseboard header pin connectors) are no taller than 4 mm. However, please note that the maximum component height may change based on the chosen baseboard connector.

4.1.1 Mechanical Retention

Certain applications where the modem is mounted on the host board using the connector approach detailed in section 4.1 may need to mechanically secure the Skywire modem & its SIM card in order to prevent the modem from vibrating out of the mating connectors. Skywire modems do not have any dedicated attachment points for securing to the host board, however it can easily be secured by one of the following methods:

- Zip ties
- Foam tape mounted on the Skywire to press against the enclosure
- Mechanical retention of the modem & SIM by the enclosure ([example](#))
- Solder the Skywire to the host board (as described in Section 4.2)

4.2 Solder to Board Connection

Alternatively, Skywires can be soldered directly to a PCB. The PCB should be designed with two rows of ten 0.8mm plated through holes spaced 2mm apart. See the figure below for the recommended footprint.

Note: All measurements are in millimeters. U.FL connectors X1 and X3 are on the top side of the board. Micro SIM card slot J3 is on the bottom of the board.

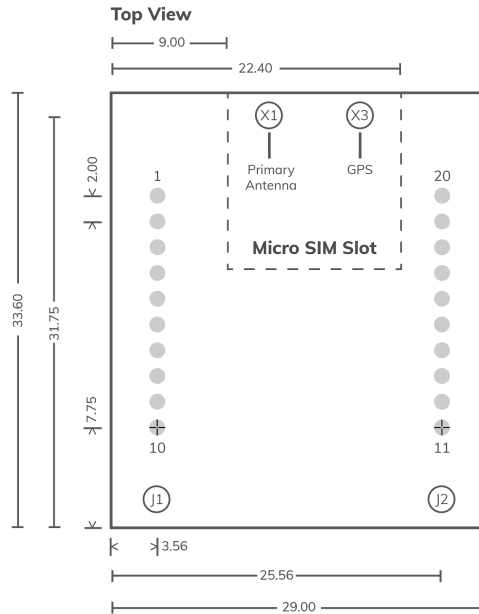

When using soldering directly to a PCB, ensure that any baseboard components placed under the Skywire (between the baseboard header pin connectors) are no taller than 0.5 mm.

5. Regulatory information

5.1 Carrier Specific Certifications

NL-SW-LTE-QBG96: Verizon ODI, PTCRB, AT&T, GCF, Telus, Orange

5.2 Export Control Classification Number (ECCN)

ECCNs are five character alphanumeric designations used on the Commerce Control List (CCL) to identify dual-use items for export control purposes. An ECCN categorizes items based on the nature of the product, i.e. type of commodity, software, or technology and its respective technical parameters.

ECCN for All Skywire Modems: 5A992.c

5.3 Harmonized Tariff Schedule Code

HTS Code: 8517.62.0010

5.4 RoHS Compliance

The NL-SW-LTE-QBG96 modem family complies with the RoHS (Restriction of Hazardous Substances) directive of the European Union, EU Directive 2011/65/EU.

5.5 Interference statement

This device complies with Part 15 of the FCC Rules and Industry Canada licence-exempt RSS standards. Operation is subject to the following two conditions: (1) This device may not cause harmful interferences, and (2) this device must accept any interference received, including interference that may cause undesired operation.

5.6 FCC & IC Compliance

If the modem's antenna is located farther than 20cm from the human body and there are no adjacent transmitters, the FCC/IC approvals of the on-board Quectel BG96 cellular module can be reused by the end product.

Should the modems antenna be mounted closer than 20cm from the human body or if there are adjacent transmitters, additional FCC/IC testing may be required for the end product.

NL-SW-LTE-QBG96 modems make use of the on-board Quectel module's FCC & IC identification numbers.

Orderable Device	FCC ID	IC ID (certification number)
NL-SW-LTE-QBG96	XMR201707BG96	10224A-201709BG96

The FCC certificate is available at the following link by searching for the FCCID listed above:

<https://www.fcc.gov/oet/ea/fccid>

The IC ID certificate is available at the following link by searching for the IC ID listed above:

<https://sms-sgs.ic.gc.ca/equipmentSearch/searchRadioEquipments?execution=e1s1&lang=en>

5.7 Wireless Notice

In order to maintain FCC/IC radiation exposure limits set forth for an uncontrolled environment alongside carrier specific certifications the antennas cannot exceed the maximum gain levels listed here:

Band	Max Antenna Gain
GSM 850	10.446 dB
GSM 1900	12.030 dB
Band 2	9.000 dB
Band 4	7.000 dB
Band 5	10.416 dB
Band 12	9.734 dB
Band 13	10.173 dB
Band 25	8.000 dB

5.8 Modification Statement

Nimbelink has not approved any changes or modifications to this device by the user. Any changes or modifications could void the user's authorization to operate the equipment.

5.9 End Product Labeling Requirements

End products utilizing NL-SW-LTE-QBG96 modems should be labeled with the following information:

Device Uses Approved Radio: NL-SW-LTE-QBG96

Contains FCC ID: XMR201707BG96

Contains IC: 10224A-201709BG96

This device complies with Part 15 of the FCC Rules and Industry Canada licence-exempt RSS standards. Operation is subject to the following two conditions: (1) This device may not cause harmful interferences, and (2) this device must accept any interference received, including interference that may cause undesired operation.

6. Document Version Information

Revision	Description	Date
12	-Corrected height of modem in modem drawing.	12/13/2019
13	-Update ON_OFF information.	4/9/2020
14	-Clarified DTR usage information.	4/20/2020
15	-Updated extended voltage range spec.	5/21/2020