

PIANO SWITCHES (FULL PITCH)

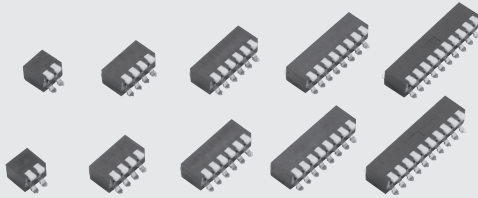

RoHS compliant



FEATURES

- Low profile design of 5 mm
- Excellent contact stability by twin gold-plated contact
- Washable type available by seal tape
- RoHS compliant
- Fine click action

INTERNAL STRUCTURE

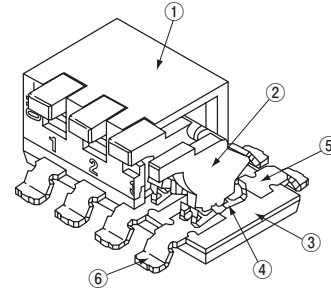

Part name	Material	Flammability
① Cover	Polyamide	UL94V-0
② Lever		
③ Base		
④ Slider contact	Copper alloy, Gold-plated	-
⑤ Fixed contact		
⑥ Terminal pin		

APPLICATIONS

- OA equipments, communication devices
- Measurement equipment, FA equipment

PART NUMBER DESIGNATION

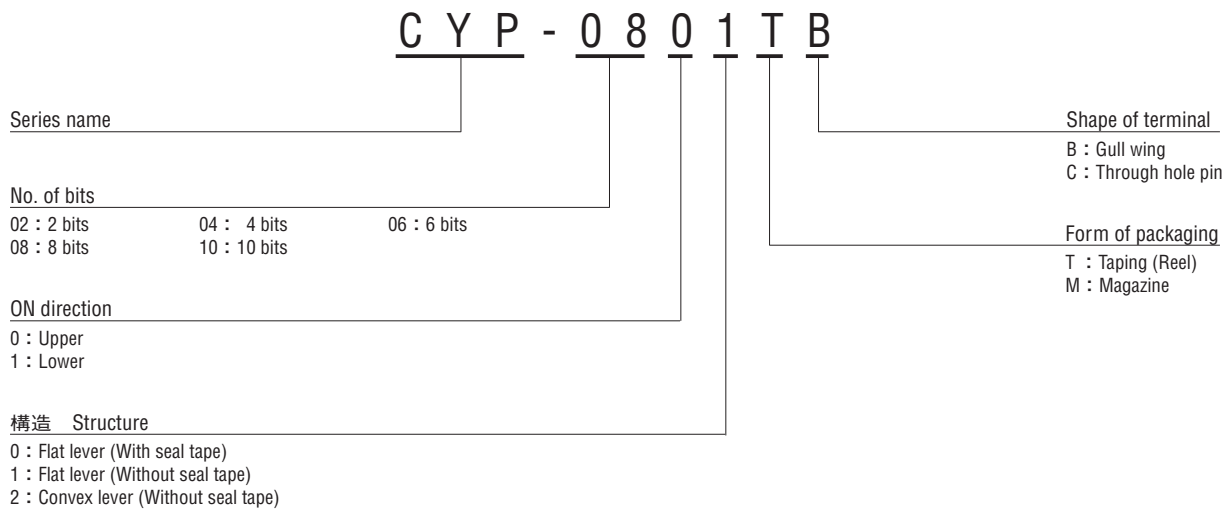

※ Please refer to the LIST OF PART NUMBERS when placing orders.

CYP

PIANO SWITCHES (FULL PITCH)

LIST OF PART NUMBERS

No. of bits	ON direction	Structure Form of packaging	Flat lever (Without seal tape)		Convex lever (Without seal tape)		Flat lever (With seal tape)		Pieces in package
			B (Gull wing)	C (Through hole pins)	B (Gull wing)	C (Through hole pins)	B (Gull wing)	C (Through hole pins)	
2	Upper	Taping	CYP-0201TB	—	CYP-0202TB	—	CYP-0200TB	—	700 pcs./reel
		Magazine	CYP-0201MB	CYP-0201MC	CYP-0202MB	CYP-0202MC	CYP-0200MB	CYP-0200MC	70 pcs./stick
	Lower	Taping	CYP-0211TB	—	CYP-0212TB	—	CYP-0210TB	—	700 pcs./reel
		Magazine	CYP-0211MB	CYP-0211MC	CYP-0212MB	CYP-0212MC	CYP-0210MB	CYP-0210MC	70 pcs./stick
4	Upper	Taping	CYP-0401TB	—	CYP-0402TB	—	CYP-0400TB	—	700 pcs./reel
		Magazine	CYP-0401MB	CYP-0401MC	CYP-0402MB	CYP-0402MC	CYP-0400MB	CYP-0400MC	40 pcs./stick
	Lower	Taping	CYP-0411TB	—	CYP-0412TB	—	CYP-0410TB	—	700 pcs./reel
		Magazine	CYP-0411MB	CYP-0411MC	CYP-0412MB	CYP-0412MC	CYP-0410MB	CYP-0410MC	40 pcs./stick
6	Upper	Taping	CYP-0601TB	—	CYP-0602TB	—	CYP-0600TB	—	700 pcs./reel
		Magazine	CYP-0601MB	CYP-0601MC	CYP-0602MB	CYP-0602MC	CYP-0600MB	CYP-0600MC	28 pcs./stick
	Lower	Taping	CYP-0611TB	—	CYP-0612TB	—	CYP-0610TB	—	700 pcs./reel
		Magazine	CYP-0611MB	CYP-0611MC	CYP-0612MB	CYP-0612MC	CYP-0610MB	CYP-0610MC	28 pcs./stick
8	Upper	Taping	CYP-0801TB	—	CYP-0802TB	—	CYP-0800TB	—	700 pcs./reel
		Magazine	CYP-0801MB	CYP-0801MC	CYP-0802MB	CYP-0802MC	CYP-0800MB	CYP-0800MC	20 pcs./stick
	Lower	Taping	CYP-0811TB	—	CYP-0812TB	—	CYP-0810TB	—	700 pcs./reel
		Magazine	CYP-0811MB	CYP-0811MC	CYP-0812MB	CYP-0812MC	CYP-0810MB	CYP-0810MC	20 pcs./stick
10	Upper	Taping	CYP-1001TB	—	CYP-1002TB	—	CYP-1000TB	—	700 pcs./reel
		Magazine	CYP-1001MB	CYP-1001MC	CYP-1002MB	CYP-1002MC	CYP-1000MB	CYP-1000MC	16 pcs./stick
	Lower	Taping	CYP-1011TB	—	CYP-1012TB	—	CYP-1010TB	—	700 pcs./reel
		Magazine	CYP-1011MB	CYP-1011MC	CYP-1012MB	CYP-1012MC	CYP-1010MB	CYP-1010MC	16 pcs./stick

STANDARD SPECIFICATIONS

Operating temp. range	- 40 ~ 85 °C
Storage temp. range	
Sealing	Washable type available with seal tape
Net weight	Approx. 0.28 g (CYP-02) Approx. 0.50 g (CYP-04) Approx. 0.73 g (CYP-06) Approx. 0.97 g (CFP-08) Approx. 1.16 g (CFP-10)

ELECTRICAL CHARACTERISTICS

Contact rating Non-switching Switching Minimum	DC50 V 100 mA DC6 V, 100 mA DC24 V, 25 mA DC20 mV 1 μA
Contact resistance	100 m Ω maximum
Insulation resistance	1000 M Ω (DC100 V) minimum
Dielectric strength	AC500 V, 60 s

MECHANICAL CHARACTERISTICS

Operation force	0.3 ~ 5 N {0.03 ~ 0.51 kgf} maximum
Stop strength	8 N {0.82 kgf} 60 s
Solderability	245 ± 3 °C, 2 ~ 3 s
Soldering heat	Reflow : 255 °C (Peak temperature) Flow : 260 ± 3 °C, 5 ~ 6 s, two times maximum (Please refer to the profile below)
	Manual soldering : 350 ± 10 °C, 3 ~ 4 s
Shear (Adhesion)	5 N {0.51 kgf} 10 s
Substrate bending	Width 90 mm, bend 3 mm, 5 s, 1 time
Pull-off strength	5 N {0.51 kgf} 10 s

ENVIRONMENTAL CHARACTERISTICS

Vibration	(Amplitude) 1.5 mm or (Acceleration) 98 m/s ² , 10-500 Hz, 3 directions for 10 cycles each
Shock	490 m/s ² , 11 ms, 6 directions for 3 times each
Load life	Continuous load 500 cycles, DC6 ± 0.5 V, 100 ± 10 mA
Humidity	-10 ~ 65 °C, Relative humidity 0 ~ 96 %, 24 h for 10 cycles
High temp. exposure	85 °C, 96 h
Low temp. exposure	-40 °C, 96 h
Thermal shock	-40 (0.5 h) ~ 85 °C (0.5 h), 5 cycles

{ } : Reference only

◀Reflow profile for soldering heat evaluation▶

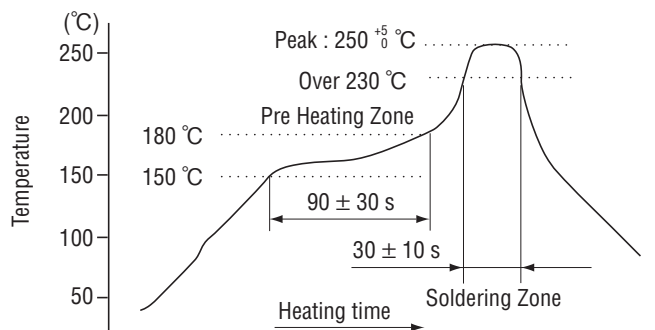

Reflow : two times maximum

OUTLINE DIMENSIONS

Unless otherwise specified, tolerance : ± 0.3 (Unit : mm)

● Flat lever, Gull wing

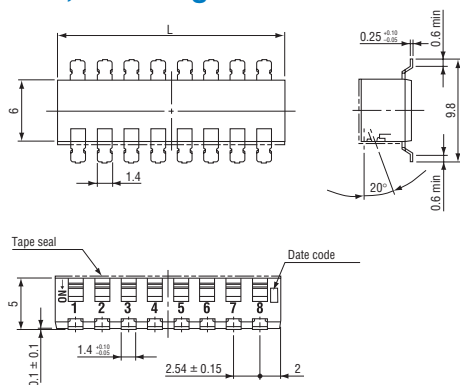

● Flat lever, Through hole pin

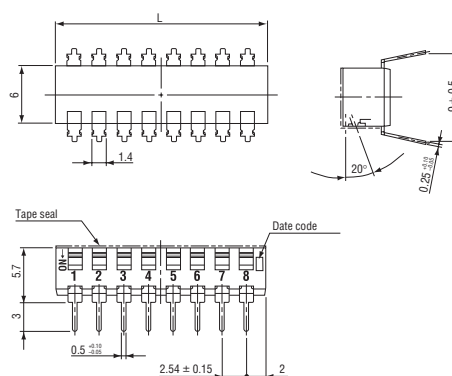

● Convex lever, Gull wing

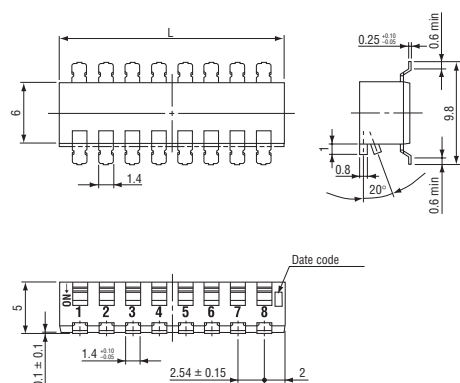

● Convex lever, Through hole pin

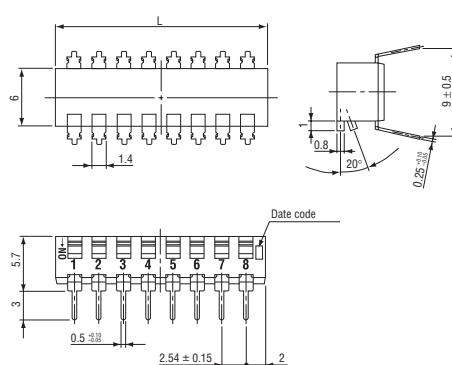

Part number	Schematic	No. of bits.	L dimension
CYP-02		2	6.48
CYP-04		4	11.56
CYP-06		6	16.64
CYP-08		8	21.72
CYP-10		10	26.8

CYP

PIANO SWITCHES (FULL PITCH)

RECOMMENDED P.C.B. PAD DIMENSIONS

(Unit : mm)

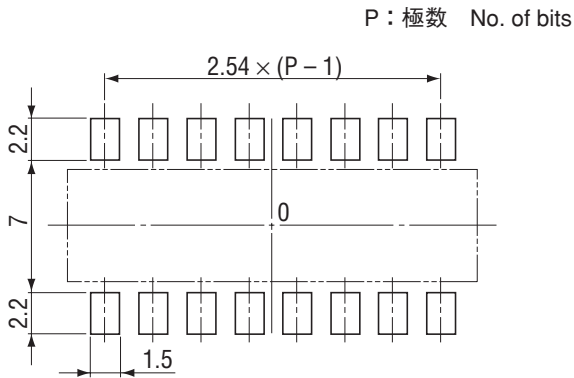

SIZE OF P.C.B. PROCESSING

(Unit : mm)

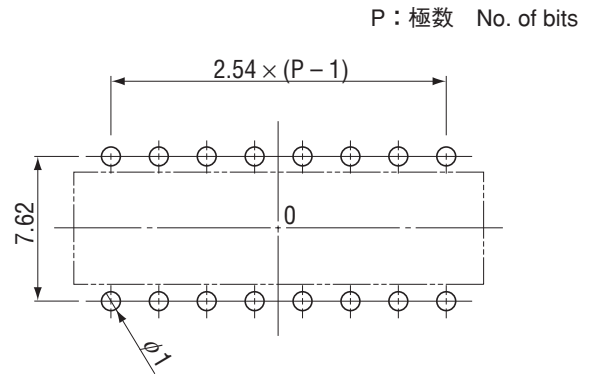

PACKAGING SPECIFICATIONS

<Taping packaging specifications>

- Taping version are packaged in 700 pcs. per reel. Orders will be accepted for units of 700 pcs., i.e., 700, 1400, 2100 pcs., etc.

- Taping version is boxed with 1 reel.

Maximum number of consecutive missing pieces = 2
Leader length and reel dimension are shown in the diagrams below:

● Embossed tape dimensions

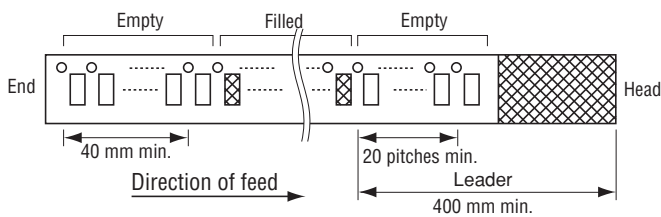

● Reel dimensions

(Unit: mm)

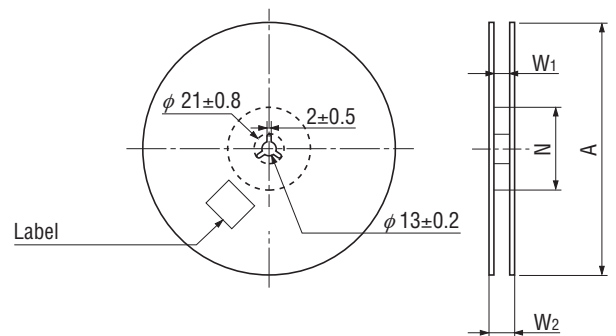

(Unit: mm)

No. of bits	A	W ₁	W ₂	N
2	$\phi 330 \pm 2$	17.4 ± 1	21.4 ± 1	$\phi 80 \pm 1$
4		25.4 ± 1	29.4 ± 1	
6		33.4 ± 1	37.4 ± 1	
8		45.4 ± 1	49.4 ± 1	
10		45.4 ± 1	49.4 ± 1	

CYP

PIANO SWITCHES (FULL PITCH)

Unless otherwise specified, tolerance : ± 0.3 (Unit : mm)

● 2 bits, 4 bits, 6 bits

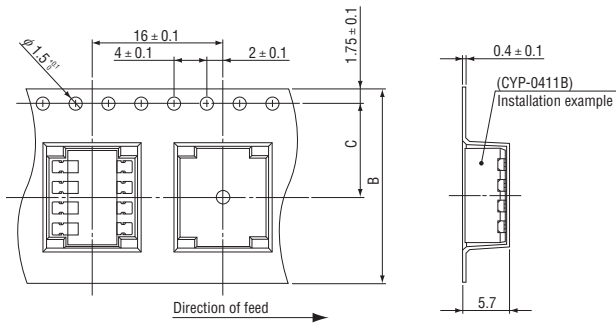

● 8 bits, 10 bits

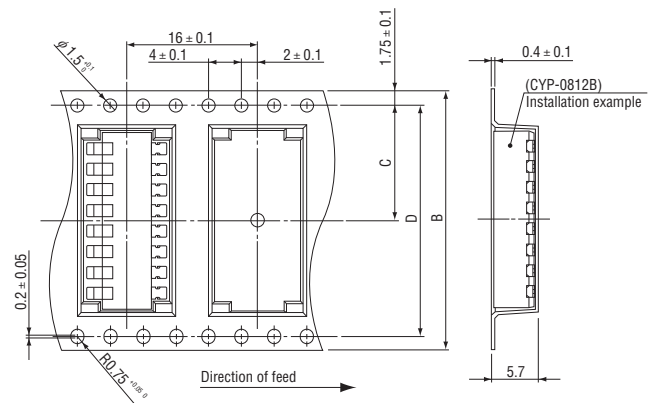

(Unit: mm)

No. of bits	B	C	D
2	16	7.5 ± 0.1	—
4	24	11.5 ± 0.1	
6			
8	32	14.2 ± 0.1	28.4 ± 0.1
10	42	20.2 ± 0.1	40.4 ± 0.1

<Magazine packaging specifications>

- Packing quantities of magazines are different depending on the bit number of the switches.
Please order the multiple numbers of the specific packing quantities. (e.g. 70 pcs., 140 pcs., 210 pcs., etc., in case of 2 bits version)

Pieces in package : 2 bits, 70 pcs./stick
 4 bits, 40 pcs./stick
 6 bits, 28 pcs./stick
 8 bits, 20 pcs./stick
 10 bits, 16 pcs./stick