

# NHD-C12864A1Z-FSR-FBW-HTT

## COG (Chip-On-Glass) Liquid Crystal Display Module

NHD- Newhaven Display  
C12864- 128 x 64 Pixels  
A1Z- Model  
F- Transflective  
SR- Side Red LED Backlight  
F- FSTN Positive  
B- 6:00 Optimal View  
W- Wide Temp  
HTT- With 12V Heater (-40°C to +70°C)  
**RoHS Compliant**

### Newhaven Display International, Inc.

2661 Galvin Ct.

Elgin IL, 60124

Ph: 847-844-8795

Fax: 847-844-8796

[www.newhavendisplay.com](http://www.newhavendisplay.com)

[nhtech@newhavendisplay.com](mailto:nhtech@newhavendisplay.com)

[nhsales@newhavendisplay.com](mailto:nhsales@newhavendisplay.com)

## Document Revision History

Revision	Date	Description	Changed by
0	10/20/10	Initial Release	-
1	10/26/10	Pin Length Adjusted from 0.5" to 0.3" on Mechanical drawing.	MC
2	10/27/10	Supply Current and block diagram updated	BE
3	1/20/11	Operating Temp updated	BE
4	8-31-11	Electrical characteristics updated	AK
5	7/30/12	Electrical characteristics updated	AK
6	8/31/15	Electrical characteristics, Mechanical drawing updated	SB
7	6/4/19	Added PCB Footprint Drawing	AS
8	1/31/20	Glass Panel Updated	SB

## Functions and Features

- 128 x 64 pixels
- Built-in ST7565P controller
- +3.3V power supply
- 1/65 duty cycle; 1/9 bias
- Built-in Heater
- RoHS Compliant

SYMBOL	REVISION	DATE

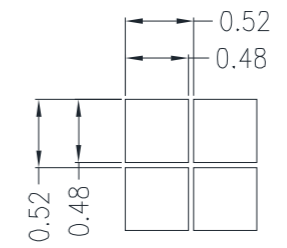
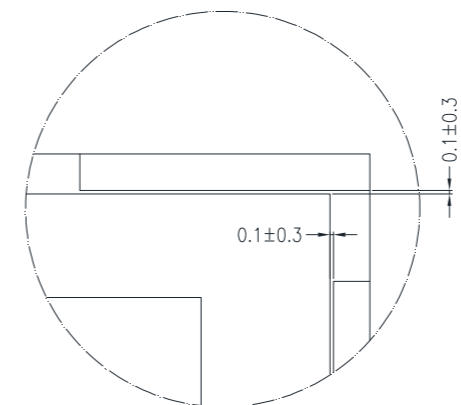
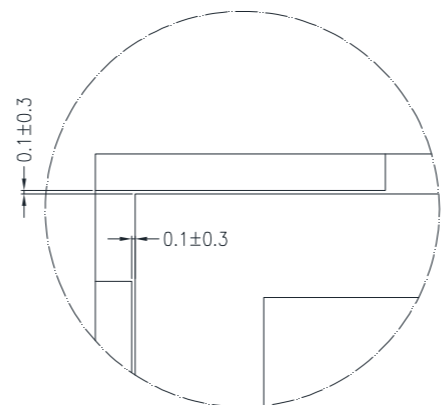
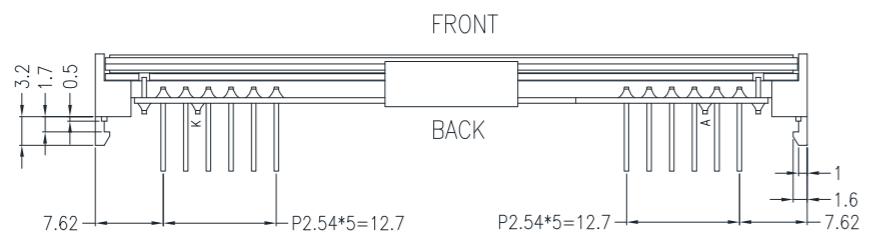
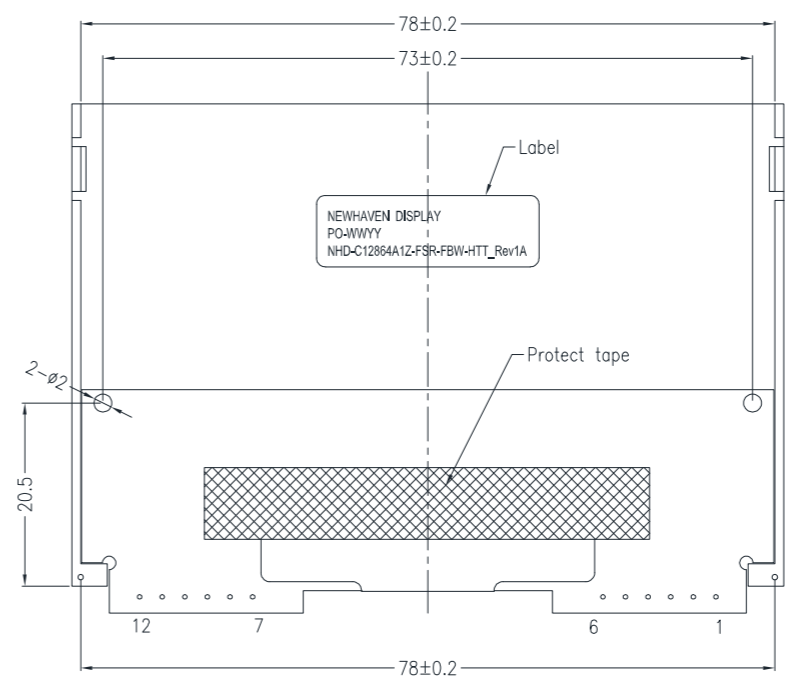
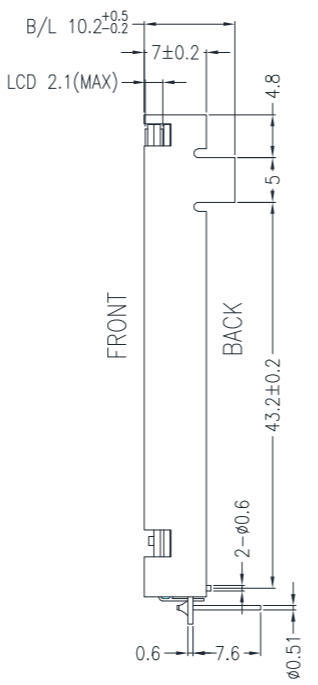
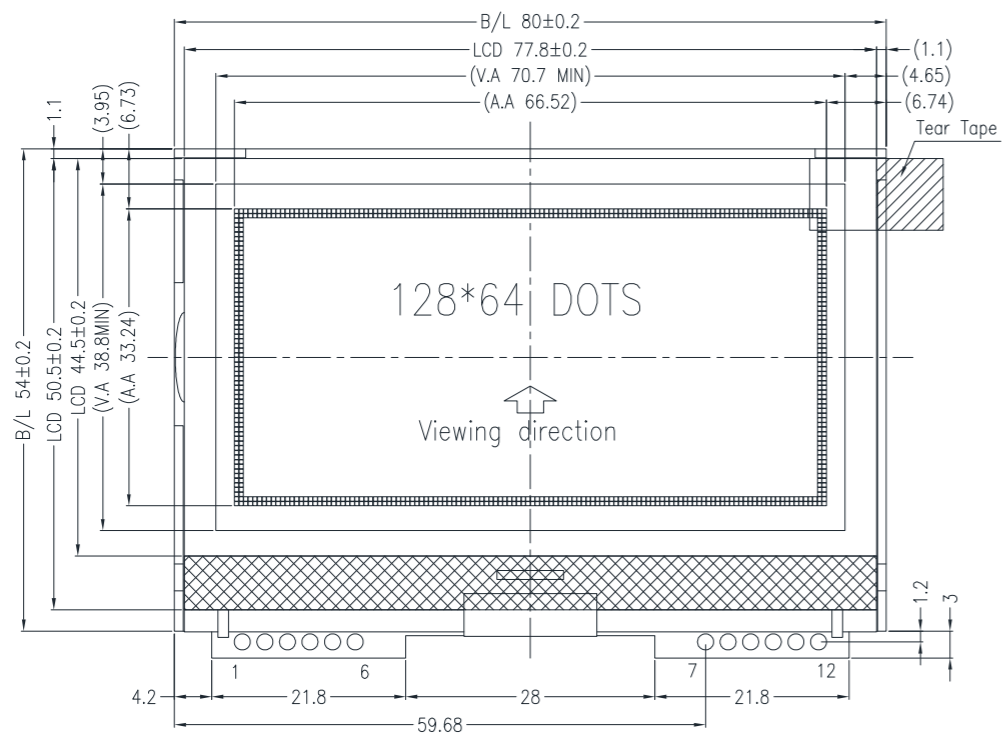

Pin assignment	
NO.	Symbol
1	SCL
2	SI
3	VDD
4	A0
5	/RESET
6	/CS
7	VSS
8	H-
9	H+
10	LED-
11	LED+
12	NC

**Notes:**

- Driving: 1/65 duty, 1/9 bias
- Voltage: 3.3V V<sub>DD</sub>, 8.7V V<sub>LCD</sub>
- Display Type: FSTN Positive / Transflective
- Optimal View: 6:00
- Backlight: Red Edge light LED`
- Driver IC: ST7565 2-Line SPI Interface
- Built-in Heater

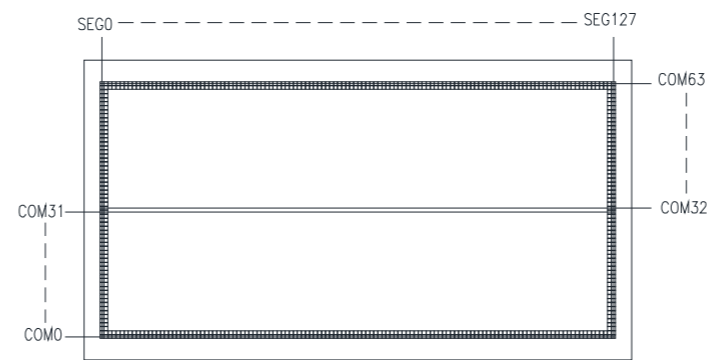

STANDARD TOLERANCE: (UNLESS OTHERWISE SPECIFIED)	NEWHAVEN DISPLAY INTERNATIONAL	
LINEAR: ±0.3mm	DRAWING/PART NUMBER: NHD-C12864A1Z-FSR-FBW-HTT	REVISION: 1A
UNLESS OTHERWISE SPECIFIED: - DIMENSIONS ARE IN MILLIMETERS - THIRD ANGLE PROJECTION	DRAWN BY: S. Baxi	APPROVED BY: S. Baxi
	DRAWN DATE: 1/31/20	APPROVED DATE: 1/31/20
	DO NOT SCALE DRAWING	
	SHEET 1 OF 1	

THIS DRAWING IS SOLELY THE PROPERTY OF NEWHAVEN DISPLAY INTERNATIONAL, INC. THE INFORMATION IT CONTAINS IS NOT TO BE DISCLOSED, REPRODUCED OR COPIED IN WHOLE OR PART WITHOUT WRITTEN APPROVAL FROM NEWHAVEN DISPLAY.

# Recommended PCB Footprint

SYMBOL	REVISION	DATE

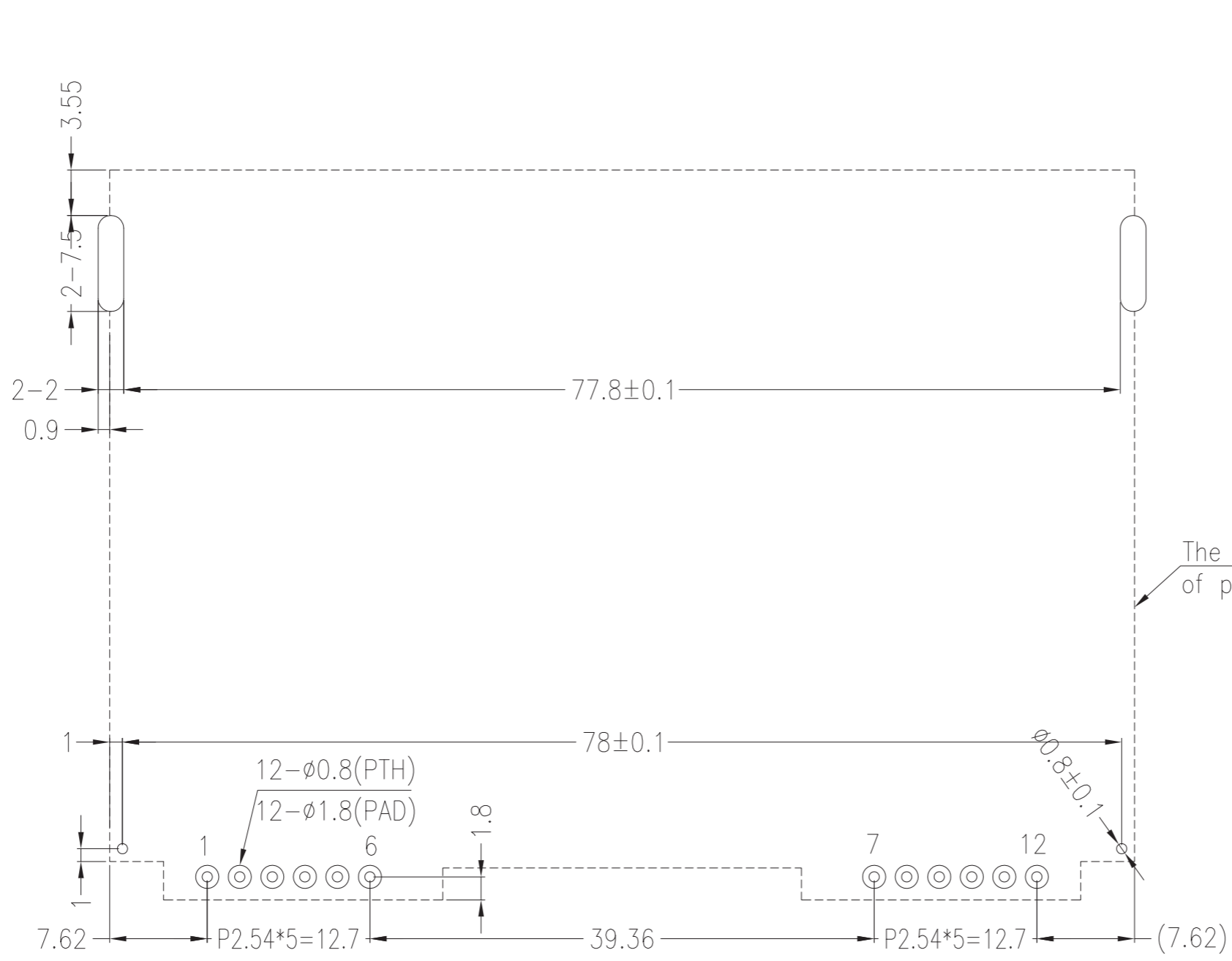

- Applicable Displays:**
- 1) NHD-C12864A1Z-FSW-FBW-HTT
  - 2) NHD-C12864A1Z-FSR-FBW-HTT
  - 3) NHD-C12864A1Z-FSB-FBW-HTT

STANDARD TOLERANCE: (UNLESS OTHERWISE SPECIFIED)		
	LINEAR: ±0.3mm	REVISION: 1.0
UNLESS OTHERWISE SPECIFIED: - DIMENSIONS ARE IN MILLIMETERS - THIRD ANGLE PROJECTION	DRAWING/PART NUMBER: NHD-C12864A1Z-Monochrome-Footprint	
	DRAWN BY: A. Shah	APPROVED BY: A. Khan
DO NOT SCALE DRAWING	DRAWN DATE: 6/3/19	APPROVED DATE: 6/3/19
	SHEET 1 OF 1	
THIS DRAWING IS SOLELY THE PROPERTY OF NEWHAVEN DISPLAY INTERNATIONAL, INC. THE INFORMATION IT CONTAINS IS NOT TO BE DISCLOSED, REPRODUCED OR COPIED IN WHOLE OR PART WITHOUT WRITTEN APPROVAL FROM NEWHAVEN DISPLAY.		

## Pin Description and Wiring Diagram

Pin No.	Symbol	External Connection	Function Description
1	SCL	MPU	Serial Clock Input
2	SI	MPU	Serial Data Input
3	V <sub>DD</sub>	Power Supply	Supply Voltage for LCD and Logic (+3.0V)
4	A0	MPU	Register Select. 0: instruction; 1: data
5	/RESET	MPU	Operation Active LOW Reset signal
6	/CS	MPU	Active LOW Chip Select Signal
7	V <sub>SS</sub>	Power Supply	Ground
8	H-	Power Supply	Ground for Heater
9	H+	Power Supply	Power for Heater (+12V)
10	LED-	Power Supply	Backlight Cathode (Ground)
11	LED+	Power Supply	Backlight Anode (+3.3V)
12	NC	-	No Connect

**Recommended LCD connector:** 2.54mm pitch thru-hole connection on PCB

**Backlight connector:** --- Mates with: ---

**Recommended Breakout Board:** [NHD-PCB40](#)

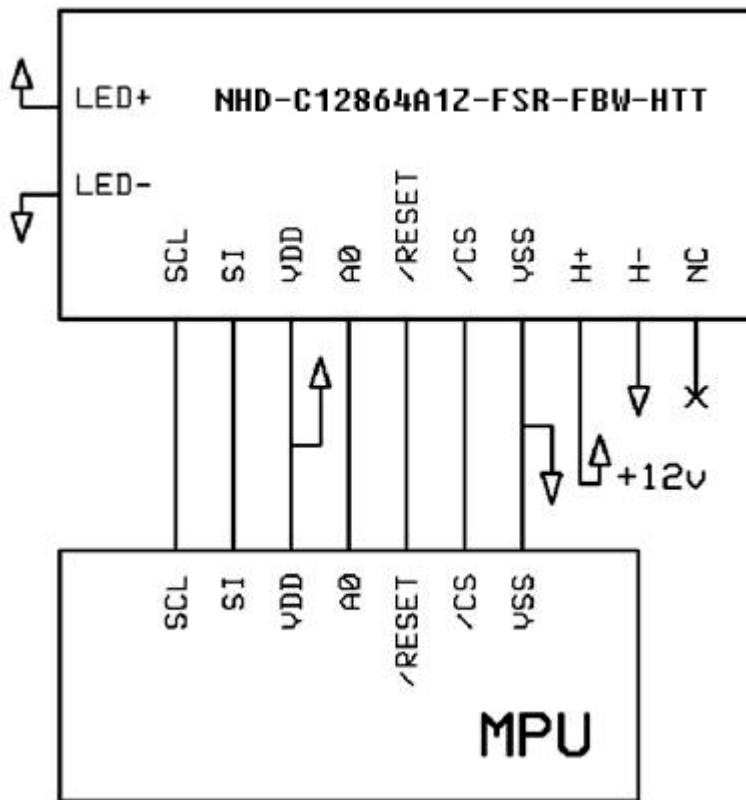

## Electrical Characteristics

Item	Symbol	Condition	Min.	Typ.	Max.	Unit
Operating Temperature Range	T <sub>OP</sub>	Absolute Max	-40	-	+70	°C
Storage Temperature Range	T <sub>ST</sub>	Absolute Max	-30	-	+80	°C
Supply Voltage	V <sub>DD</sub>	-	2.7	3.0	3.3	V
Supply Current	I <sub>DD</sub>	T <sub>OP</sub> =25°C	0.1	0.5	1.0	mA
Supply for LCD (contrast)	V <sub>DD-V0</sub>	V <sub>DD</sub> =3.3V	8.5	8.7	8.9	V
"H" Level input	V <sub>IH</sub>	-	0.8 * V <sub>DD</sub>	-	V <sub>DD</sub>	V
"L" Level input	V <sub>IH</sub>	-	V <sub>SS</sub>	-	0.2 * V <sub>DD</sub>	V
"H" Level output	V <sub>OH</sub>	-	0.8 * V <sub>DD</sub>	-	V <sub>DD</sub>	V
"L" Level output	V <sub>OL</sub>	-	V <sub>SS</sub>	-	0.2 * V <sub>DD</sub>	V
Backlight Supply Voltage	V <sub>LED</sub>	-	3.2	3.3	3.4	V
Backlight Supply Current	I <sub>LED</sub>	V <sub>LED</sub> = 3.3V	30	60	75	mA
Heater panel resistance	R <sub>H+/-</sub>	-	10	20	30	Ω
Heater Voltage Supply	V <sub>H</sub>	-	-	12	15	V
Heater Current	I <sub>H</sub>	V <sub>H</sub> = 12.0V	0.40	0.6	1.2	A
Heater Power	W <sub>H</sub>	-	4.8	7.2	14.4	W

## Optical Characteristics

Item	Symbol	Condition	Min.	Typ.	Max.	Unit
Optimal Viewing Angles	Top	CR ≥ 2	-	20	-	°
	Bottom		-	40	-	°
	Left		-	40	-	°
	Right		-	40	-	°
Contrast Ratio	CR	-	2	8	-	-
Response Time	Rise	T <sub>OP</sub> = 25°C	-	200	250	ms
	Fall		-	250	320	ms

## Controller Information

Built-in ST7565P controller.

Please download specification at [http://www.newhavendisplay.com/app\\_notes/ST7565.pdf](http://www.newhavendisplay.com/app_notes/ST7565.pdf)

# Timing Characteristics

## The Serial Interface

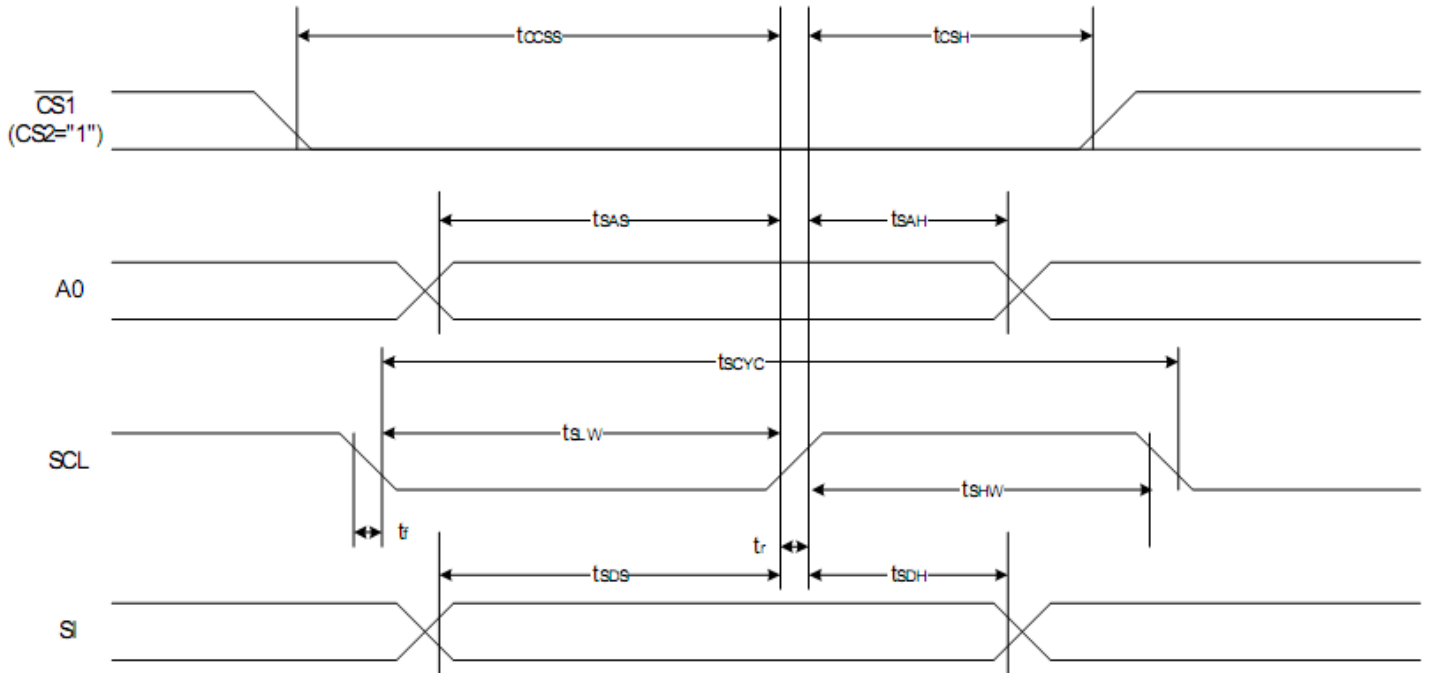

Item	Signal	Symbol	Condition	Rating		Units
				Min.	Max.	
Serial Clock Period	SCL	$t_{SCYC}$		400	—	ns
SCL "H" pulse width		$t_{SHW}$		120	—	
SCL "L" pulse width		$t_{SLW}$		120	—	
Address setup time	A0	$t_{SAS}$		50	—	
Address hold time		$t_{SAH}$		50	—	
Data setup time	SI	$t_{SDS}$		50	—	
Data hold time		$t_{SDH}$		50	—	
CS-SCL time	CS	$t_{CSS}$		50	—	
CS-SCL time		$t_{CSH}$		150	—	

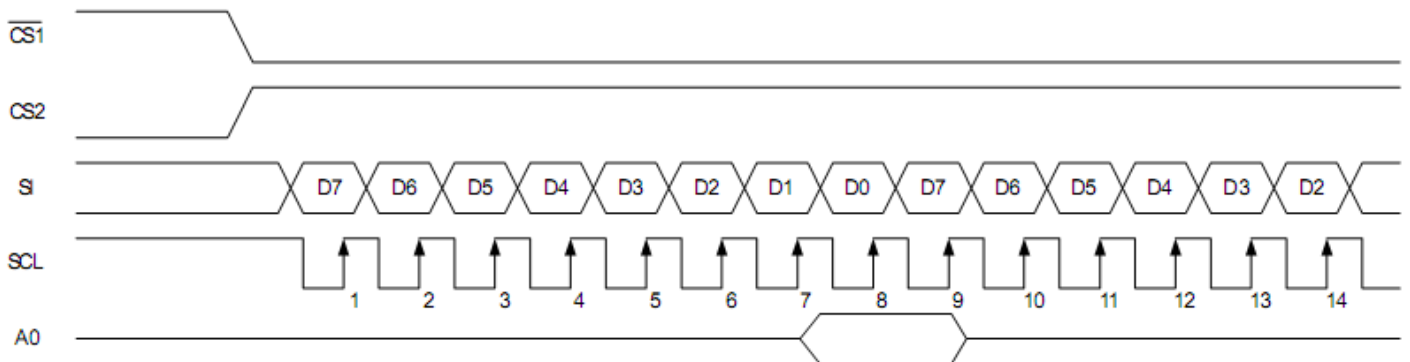

## Table of Commands

Command	Command Code									Function			
	A0	/RD	/WR	D7	D6	D5	D4	D3	D2		D1	D0	
(1) Display ON/OFF	0	1	0	1	0	1	0	1	1	1	0	1	LCD display ON/OFF 0: OFF, 1: ON
(2) Display start line set	0	1	0	0	1	Display start address						Sets the display RAM display start line address	
(3) Page address set	0	1	0	1	0	1	1	Page address				Sets the display RAM page address	
(4) Column address set upper bit	0	1	0	0	0	0	1	Most significant column address				Sets the most significant 4 bits of the display RAM column address.	
Column address set lower bit	0	1	0	0	0	0	0	Least significant column address				Sets the least significant 4 bits of the display RAM column address.	
(5) Status read	0	0	1	Status				0	0	0	0	0	Reads the status data
(6) Display data write	1	1	0	Write data								Writes to the display RAM	
(7) Display data read	1	0	1	Read data								Reads from the display RAM	
(8) ADC select	0	1	0	1	0	1	0	0	0	0	0	1	Sets the display RAM address SEG output correspondence 0: normal, 1: reverse
(9) Display normal/reverse	0	1	0	1	0	1	0	0	1	1	0	1	Sets the LCD display normal/reverse 0: normal, 1: reverse
(10) Display all points ON/OFF	0	1	0	1	0	1	0	0	1	0	0	1	Display all points 0: normal display 1: all points ON
(11) LCD bias set	0	1	0	1	0	1	0	0	0	1	0	1	Sets the LCD drive voltage bias ratio 0: 1/9 bias, 1: 1/7 bias (ST7565)
(12) Read/modify/write	0	1	0	1	1	1	0	0	0	0	0	0	Column address increment At write: +1 At read: 0
(13) End	0	1	0	1	1	1	0	1	1	1	0	0	Clear read/modify/write
(14) Reset	0	1	0	1	1	1	0	0	0	1	0	0	Internal reset
(15) Common output mode select	0	1	0	1	1	0	0	0	1	*	*	*	Select COM output scan direction 0: normal direction 1: reverse direction
(16) Power control set	0	1	0	0	0	1	0	1	Operating mode			Select internal power supply operating mode	
(17) Vs voltage regulator internal resistor ratio set	0	1	0	0	0	1	0	0	Resistor ratio			Select internal resistor ratio(Rb/Ra) mode	
(18) Electronic volume mode set	0	1	0	1	0	0	0	0	0	0	0	1	Set the Vs output voltage electronic volume register
Electronic volume register set				0	0	Electronic volume value							
(19) Static indicator ON/OFF	0	1	0	1	0	1	0	1	1	0	0	1	0: OFF, 1: ON
Static indicator register set				0	0	0	0	0	0	0	Mode	Set the flashing mode	
(20) Power saver													Display OFF and display all points ON compound command
(21) NOP	0	1	0	1	1	1	0	0	0	1	1	1	Command for non-operation
(22) Test	0	1	0	1	1	1	1	*	*	*	*	*	Command for IC test. Do not use this command



# Example Initialization Program

```
.....  
Sub Command  
Reset P3.7  
Reset P3.4  
For Writecount = 1 To 8  
Rotate A , Left , 1  
Reset P3.1  
P1 = A  
Set P3.1  
Next Writecount  
Set P3.7  
End Sub  
.....
```

```
Sub Write  
Reset P3.7  
Set P3.4  
For Writecount = 1 To 8  
Rotate A , Left , 1  
Reset P3.1  
P1 = A  
Set P3.1  
Next Writecount  
Set P3.7  
End Sub  
.....
```

```
Sub Init  
Waitms 100  
A = &HA0  
Call Command  
A = &HAE  
Call Command  
A = &HC0  
Call Command  
A = &HA2  
Call Command  
A = &H2F  
Call Command  
A = &H26  
Call Command  
A = &H81  
Call Command  
A = &H11  
Call Command  
A = &HAF  
Call Command  
End Sub  
.....
```

## Quality Information

Test Item	Content of Test	Test Condition	Note
High Temperature storage	Endurance test applying the high storage temperature for a long time.	+80°C, 96hrs	2
Low Temperature storage	Endurance test applying the low storage temperature for a long time.	-30°C, 96hrs	1,2
High Temperature Operation	Endurance test applying the electric stress (voltage & current) and the high thermal stress for a long time.	+70°C, 96hrs	2
Low Temperature Operation	Endurance test applying the electric stress (voltage & current) and the low thermal stress for a long time.	-20°C, 96hrs	1,2
High Temperature / Humidity Operation	Endurance test applying the electric stress (voltage & current) and the high thermal with high humidity stress for a long time.	+50°C, 90% RH, 96hrs	1,2
Thermal Shock resistance	Endurance test applying the electric stress (voltage & current) during a cycle of low and high thermal stress.	-0°C, 30min -> 25°C, 5min -> 50°C, 30min = 1 cycle For 10 cycles	
Vibration test	Endurance test applying vibration to simulate transportation and use.	10-55Hz, 1.5mm amplitude. 60 sec in each of 3 directions X, Y, Z For 15 minutes	3
Static electricity test	Endurance test applying electric static discharge.	VS=800V, RS=1.5kΩ, CS=100pF Ten Times	

**Note 1:** No condensation to be observed.

**Note 2:** Conducted after 4 hours of storage at 25°C, 0%RH.

**Note 3:** Test performed on product itself, not inside a container.

## Precautions for using LCDs/LCMs

See Precautions at [www.newhavendisplay.com/specs/precautions.pdf](http://www.newhavendisplay.com/specs/precautions.pdf)

## Warranty Information and Terms & Conditions

[http://www.newhavendisplay.com/index.php?main\\_page=terms](http://www.newhavendisplay.com/index.php?main_page=terms)