

NHD-2.8-25664UCY2

Graphic OLED Display Module

NHD-	Newhaven Display
2.8-	2.8" Diagonal Size
25664-	256 x 64 Pixel Resolution
UC-	Model
Y-	Emitting Color: Yellow
2-	3V Power Supply

Newhaven Display International, Inc.

2661 Galvin Ct.

Elgin IL, 60124

Ph: 847-844-8795

Fax: 847-844-8796

www.newhavendisplay.com

nhtech@newhavendisplay.com

nhsales@newhavendisplay.com

Document Revision History

Revision	Date	Description	Changed by
0	5/1/11	Initial Product Release	-
1	2/22/13	Electrical characteristics and mechanical drawing updated	JN
2	3/16/20	Electrical Characteristics & Segment Layout Updated	SB

Functions and Features

- 256 x 64 pixel resolution
- Built-in SSD1322 controller
- Parallel or serial MPU interface
- Single, low voltage power supply
- RoHS compliant

SYMBOL	REVISION	DATE

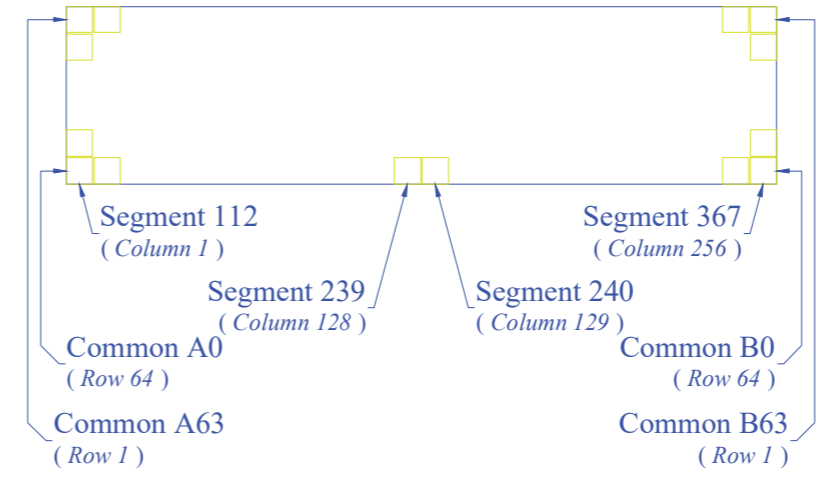
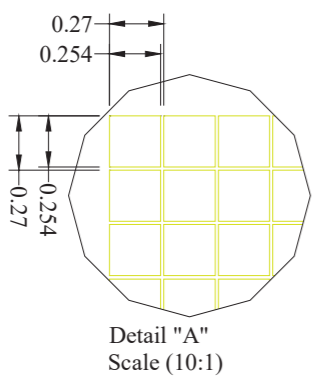
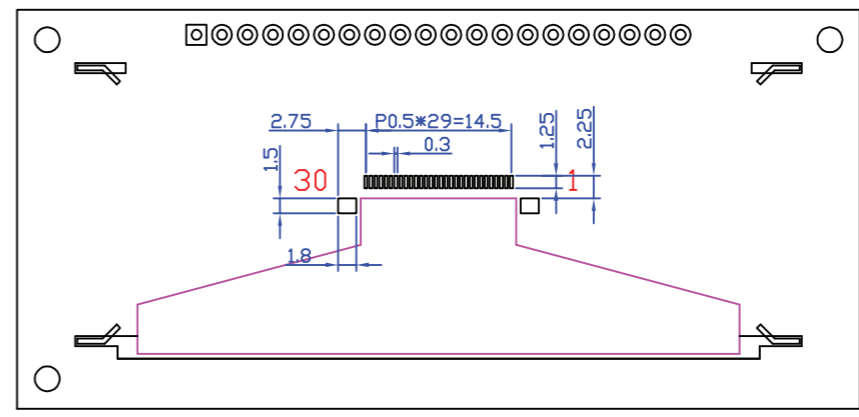
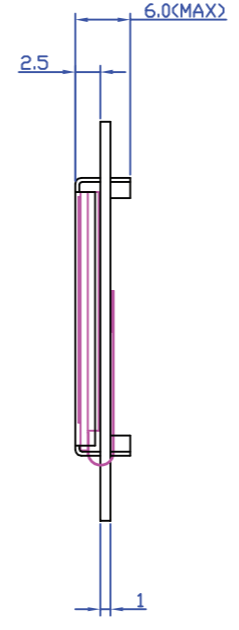
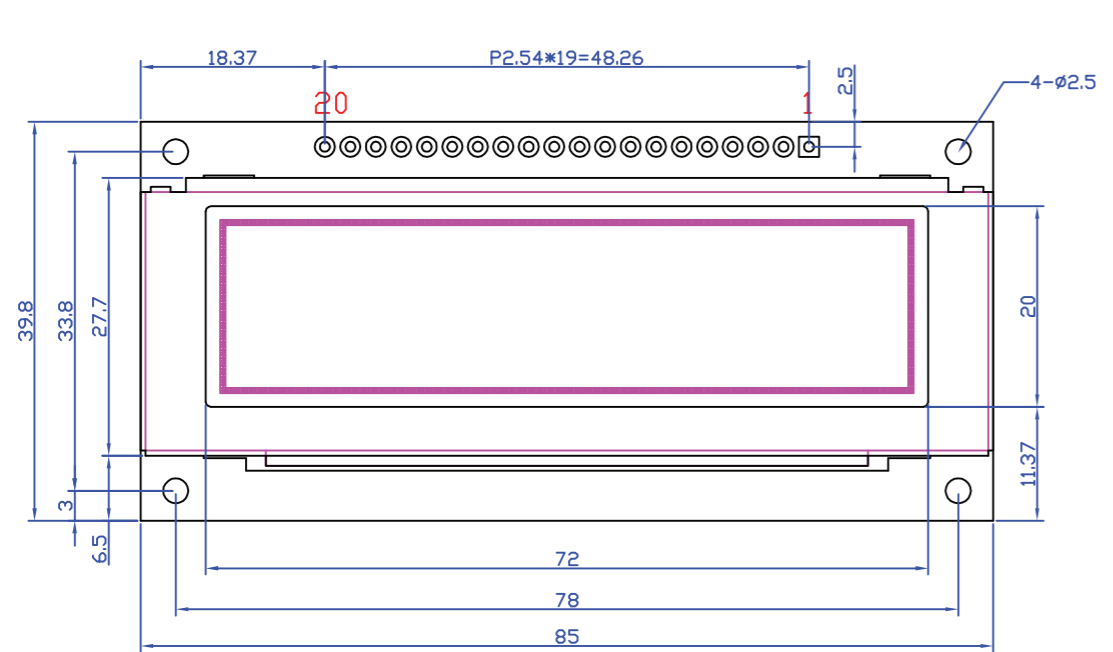

Pin No.	Symbol
1	VSS
2	VDD
3	NC
4	D/C
5	R/W or /WR
6	E or /RD
7-14	DB0 – DB7
15	NC
16	/RES
17	/CS
18	NC
19	BS1
20	BS0

- Notes:**
- 1. Driver: 1/64 Duty
 - 2. Display Type: PMOLED
 - 3. Voltage: 3V VDD
 - 4. Emitting Color: Yellow
 - 5. Driver IC: SD1322
 - 6. Interface: 8-Bit 68XX/80XX Parallel, 3-/4-Wire SPI

STANDARD TOLERANCE: (UNLESS OTHERWISE SPECIFIED)

LINEAR: ±0.3mm

UNLESS OTHERWISE SPECIFIED: - DIMENSIONS ARE IN MILLIMETERS - THIRD ANGLE PROJECTION

DO NOT SCALE DRAWING

NEWHAVEN DISPLAY INTERNATIONAL

DRAWING/PART NUMBER: NHD-2.8-25664UCY2

REVISION: 1.0

SIZE: A3

SCALE: NS

SHEET 1 OF 1

THIS DRAWING IS SOLELY THE PROPERTY OF NEWHAVEN DISPLAY INTERNATIONAL, INC. THE INFORMATION IT CONTAINS IS NOT TO BE DISCLOSED, REPRODUCED OR COPIED IN WHOLE OR PART WITHOUT WRITTEN APPROVAL FROM NEWHAVEN DISPLAY.

Interface Description

Parallel Interface:

Pin No.	Symbol	External Connection	Function Description
1	V _{SS}	Power Supply	Ground
2	V _{DD}	Power Supply	Supply Voltage for OLED and logic.
3	NC	-	No Connect
4	D/C	MPU	Register select signal. D/C=0: Command; D/C=1: Data
5	R/W or /WR	MPU	6800-interface: Read/Write select signal, R/W=1: Read; R/W=0: Write 8080-interface: Active LOW Write signal.
6	E or /RD	MPU	6800-interface: Operation enable signal. Falling edge triggered. 8080-interface: Active LOW Read signal.
7-14	DB0 – DB7	MPU	8-bit Bi-directional data bus lines.
15	NC	-	No Connect
16	/RES	MPU	Active LOW Reset signal.
17	/CS	MPU	Active LOW Chip Select signal.
18	NC	-	No Connect
19	BS1	MPU	MPU Interface Select signal.
20	BS0	MPU	MPU Interface Select signal.

Serial Interface:

Pin No.	Symbol	External Connection	Function Description
1	V _{SS}	Power Supply	Ground
2	V _{DD}	Power Supply	Supply Voltage for OLED and logic.
3	NC	-	No Connect
4	D/C	MPU	Register select signal. D/C=0: Command; D/C=1: Data Tie LOW for 3-wire Serial Interface.
5-6	VSS	Power Supply	Ground
7	SCLK	MPU	Serial Clock signal.
8	SDIN	MPU	Serial Data Input signal.
9	NC	-	No Connect
10-14	VSS	Power Supply	Ground
15	NC	-	No Connect
16	/RES	MPU	Active LOW Reset signal.
17	/CS	MPU	Active LOW Chip Select signal.
18	NC	-	No Connect
19	BS1	MPU	MPU Interface Select signal.
20	BS0	MPU	MPU Interface Select signal.

MPU Interface Pin Selections

Pin Name	6800 Parallel 8-bit interface	8080 Parallel 8-bit interface	3-wire Serial Interface	4-wire Serial Interface
BS1	1	1	0	0
BS0	1	0	1	0

MPU Interface Pin Assignment Summary

Bus Interface	Data/Command Interface								Control Signals				
	D7	D6	D5	D4	D3	D2	D1	D0	E	R/W	/CS	D/C	/RES
8-bit 6800	D[7:0]								E	R/W	/CS	D/C	/RES
8-bit 8080	D[7:0]								/RD	/WR	/CS	D/C	/RES
3-wire SPI	Tie LOW				NC	SDIN	SCLK	Tie LOW		/CS	Tie LOW	/RES	
4-wire SPI	Tie LOW				NC	SDIN	SCLK	Tie LOW		/CS	D/C	/RES	

Wiring Diagrams

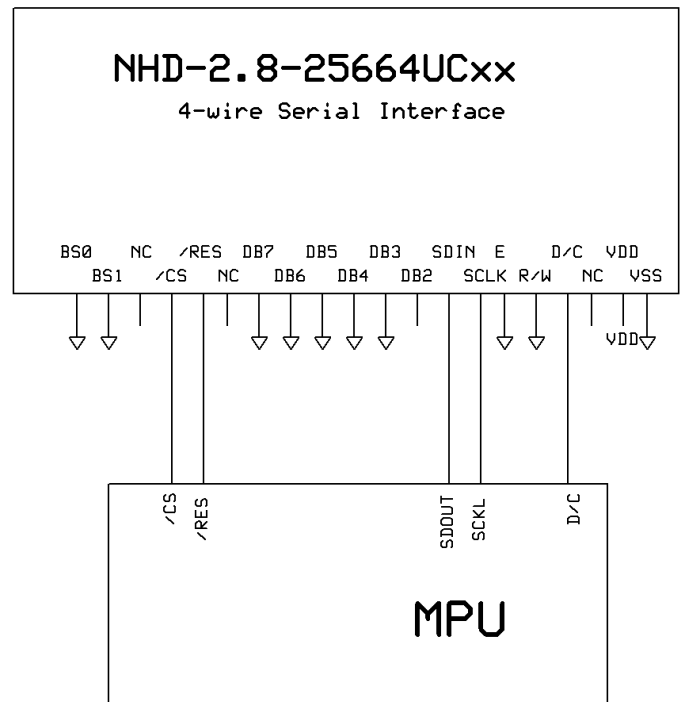
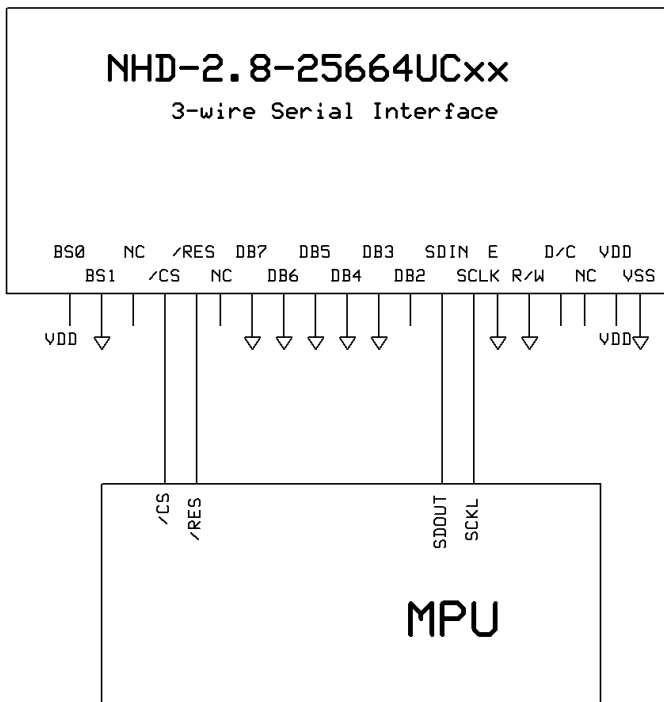
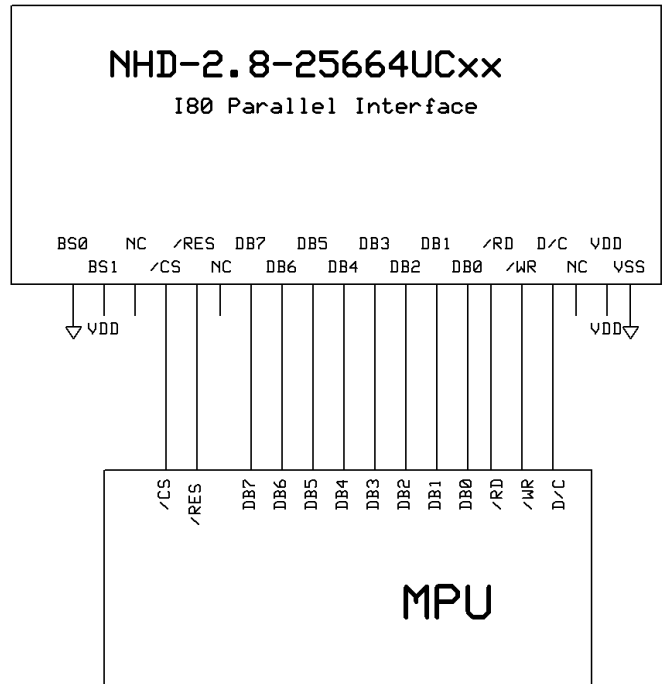
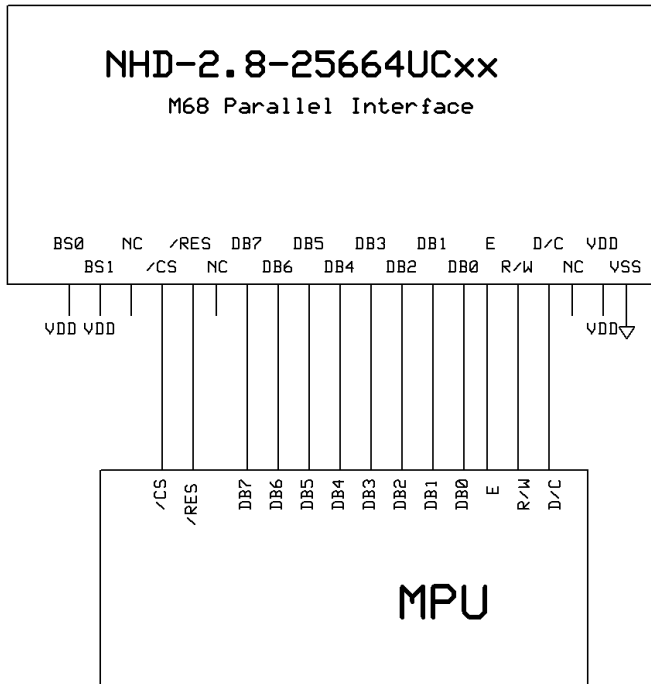

Electrical Characteristics

Item	Symbol	Condition	Min.	Typ.	Max.	Unit
Operating Temperature Range	T _{OP}	Absolute Max	-40	-	+85	°C
Storage Temperature Range	T _{ST}	Absolute Max	-40	-	+90	°C
Supply Voltage	V _{DD}	-	3.0	3.3	3.5	V
Supply Current (display)	I _{DD}	50% ON, V _{DD} =3.0V	-	150	175	mA
		100% ON, V _{DD} =3.0V	-	250	275	mA
Sleep Mode Current	I _{DD_SLEEP}	-	-	-	10	µA
“H” Level input	V _{IH}	-	0.8 * V _{DD}	-	V _{DD}	V
“L” Level input	V _{IL}	-	V _{SS}	-	0.2 * V _{DD}	V
“H” Level output	V _{OH}	-	0.9 * V _{DD}	-	V _{DD}	V
“L” Level output	V _{OL}	-	V _{SS}	-	0.1 * V _{DD}	V

Optical Characteristics

Item	Symbol	Condition	Min.	Typ.	Max.	Unit
Viewing Angle – Top	φY+		-	80	-	°
Viewing Angle – Bottom	φY-		-	80	-	°
Viewing Angle – Left	θX-		-	80	-	°
Viewing Angle – Right	θX+		-	80	-	°
Contrast Ratio	CR	-	10,000:1	-	-	-
Response Time (rise)	T _R	-	-	10	-	us
Response Time (fall)	T _F	-	-	10	-	us
Brightness	L _V	T _{OP} = 25°C	60	80	-	cd/m ²
Lifetime	-	50% Checkerboard	40,000	60,000	-	Hrs

Note: Lifetime at typical temperature is based on accelerated high-temperature operation. Lifetime is tested at average 50% pixels on and is rated as Hours until **Half-Brightness**. The Display OFF command can be used to extend the lifetime of the display.

Luminance of active pixels will degrade faster than inactive pixels. Residual (burn-in) images may occur. To avoid this, every pixel should be illuminated uniformly.

Controller Information

Built in SSD1322 Controller

For detailed information please download datasheet: http://www.newhavendisplay.com/app_notes/SSD1322.pdf

6800-MPU Parallel Interface

The parallel interface consists of 8 bi-directional data pins, R/W, D/C, E, and /CS.

A LOW on R/W indicates write operation, and HIGH on R/W indicates read operation.

A LOW on D/C indicates “Command” read or write, and HIGH on D/C indicates “Data” read or write.

The E input serves as data latch signal, while /CS is LOW. Data is latched at the falling edge of E signal.

Function	E	R/W	/CS	D/C
Write Command	↓	0	0	0
Read Status	↓	1	0	0
Write Data	↓	0	0	1
Read Data	↓	1	0	1

8080-MPU Parallel Interface

The parallel interface consists of 8 bi-directional data pins, /RD, /WR, D/C, and /CS.

A LOW on D/C indicates “Command” read or write, and HIGH on D/C indicates “Data” read or write.

A rising edge of /RS input serves as a data read latch signal while /CS is LOW.

A rising edge of /WR input serves as a data/command write latch signal while /CS is LOW.

Function	/RD	/WR	/CS	D/C
Write Command	1	↑	0	0
Read Status	↑	1	0	0
Write Data	1	↑	0	1
Read Data	↑	1	0	1

Alternatively, /RD and /WR can be kept stable while /CS serves as the data/command latch signal.

Function	/RD	/WR	/CS	D/C
Write Command	1	0	↑	0
Read Status	0	1	↑	0
Write Data	1	0	↑	1
Read Data	0	1	↑	1

Serial Interface (4-wire)

The 4-wire serial interface consists of serial clock SCLK, serial data SDIN, D/C, and /CS.

D0 acts as SCLK and D1 acts as SDIN. D2 should be left open. D3~D7, E, and R/W should be connected to GND.

Function	/RD	/WR	/CS	D/C	D0
Write Command	Tie LOW	Tie LOW	0	0	↑
Write Data	Tie LOW	Tie LOW	0	1	↑

SDIN is shifted into an 8-bit shift register on every rising edge of SCLK in the order of D7, D6,...D0.

D/C is sampled on every eighth clock and the data byte in the shift register is written to the GDRAM or command register in the same clock.

Note: Read is not available in serial mode.

Serial Interface (3-wire)

The 3-wire serial interface consists of serial clock SCLK, serial data SDIN, and /CS.

D0 acts as SCLK and D1 acts as SDIN. D2 should be left open. D3~D7, E, R/W, and D/C should be connected to GND.

Function	/RD	/WR	/CS	D/C	D0
Write Command	Tie LOW	Tie LOW	0	Tie LOW	↑
Write Data	Tie LOW	Tie LOW	0	Tie LOW	↑

SDIN is shifted into an 9-bit shift register on every rising edge of SCLK in the order of D/C, D7, D6,...D0.

D/C (first bit of the sequential data) will determine if the following data byte is written to the Display Data RAM (D/C = 1) or the command register (D/C = 0).

Note: Read is not available in serial mode.

For detailed protocol information, see datasheet: http://www.newhavendisplay.com/app_notes/SSD1322.pdf

Example Initialization Sequence:

```
Set_Command_Lock(0x12);           // Unlock Basic Commands (0x12/0x16)
Set_Display_On_Off(0x00);         // Display Off (0x00/0x01)
Set_Column_Address(0x1C,0x5B);
Set_Row_Address(0x00,0x3F);
Set_Display_Clock(0x91);          // Set Clock as 80 Frames/Sec
Set_Multiplex_Ratio(0x3F);        // 1/64 Duty (0x0F~0x3F)
Set_Display_Offset(0x00);         // Shift Mapping RAM Counter (0x00~0x3F)
Set_Start_Line(0x00);            // Set Mapping RAM Display Start Line (0x00~0x7F)
Set_Remap_Format(0x14);          // Set Horizontal Address Increment
                                  // Column Address 0 Mapped to SEG0
                                  // Disable Nibble Remap
                                  // Scan from COM[N-1] to COM0
                                  // Disable COM Split Odd Even
                                  // Enable Dual COM Line Mode
Set_GPIO(0x00);                  // Disable GPIO Pins Input
Set_Function_Selection(0x01);     // Enable Internal VDD Regulator
Set_Display_Enhancement_A(0xA0,0xFD); // Enable External VSL
Set_Contrast_Current(0x9F);       // Set Segment Output Current
Set_Master_Current(0x0F);         // Set Scale Factor of Segment Output Current Control
//Set_Gray_Scale_Table();         // Set Pulse Width for Gray Scale Table
Set_Linear_Gray_Scale_Table();    //set default linear gray scale table
Set_Phase_Length(0xE2);           // Set Phase 1 as 5 Clocks & Phase 2 as 14 Clocks
Set_Display_Enhancement_B(0x20);  // Enhance Driving Scheme Capability (0x00/0x20)
Set_Precharge_Voltage(0x1F);      // Set Pre-Charge Voltage Level as 0.60*VCC
Set_Precharge_Period(0x08);       // Set Second Pre-Charge Period as 8 Clocks
Set_VCOMH(0x07);                 // Set Common Pins Deselect Voltage Level as 0.86*VCC
Set_Display_Mode(0x02);           // Normal Display Mode (0x00/0x01/0x02/0x03)
Set_Partial_Display(0x01,0x00,0x00); // Disable Partial Display
Set_Display_On_Off(0x01);
```

Quality Information

Test Item	Content of Test	Test Condition	Note
High Temperature storage	Test the endurance of the display at high storage temperature.	+90°C, 240hrs	2
Low Temperature storage	Test the endurance of the display at low storage temperature.	-40°C, 240hrs	1,2
High Temperature Operation	Test the endurance of the display by applying electric stress (voltage & current) at high temperature.	+85°C, 240hrs	2
Low Temperature Operation	Test the endurance of the display by applying electric stress (voltage & current) at low temperature.	-40°C, 240hrs	1,2
High Temperature / Humidity Operation	Test the endurance of the display by applying electric stress (voltage & current) at high temperature with high humidity.	+60°C, 90% RH, 240hrs	1,2
Thermal Shock resistance	Test the endurance of the display by applying electric stress (voltage & current) during a cycle of low and high temperatures.	-40°C,30min -> 25°C,5min -> 85°C,30min = 1 cycle 100 cycles	
Vibration test	Test the endurance of the display by applying vibration to simulate transportation and use.	10-22Hz, 15mm amplitude. 22-500Hz, 1.5G 30min in each of 3 directions X, Y, Z	3
Atmospheric Pressure test	Test the endurance of the display by applying atmospheric pressure to simulate transportation by air.	115mbar, 40hrs	3
Static electricity test	Test the endurance of the display by applying electric static discharge.	VS=800V, RS=1.5kΩ, CS=100pF One time	

Note 1: No condensation to be observed.

Note 2: Conducted after 2 hours of storage at 25°C, 0%RH.

Note 3: Test performed on product itself, not inside a container.

Evaluation Criteria:

- 1: Display is fully functional during operational tests and after all tests, at room temperature.
- 2: No observable defects.
- 3: Luminance >50% of initial value.
- 4: Current consumption within 50% of initial value

Precautions for using OLEDs/LCDs/LCMs

See Precautions at www.newhavendisplay.com/specs/precautions.pdf

Warranty Information and Terms & Conditions

http://www.newhavendisplay.com/index.php?main_page=terms