

4611110031030

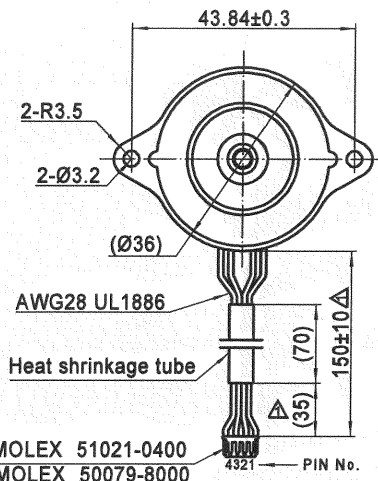

Housing: MOLEX 51021-0400  
Terminal: MOLEX 50079-8000

接线图  
Wiring Diagram

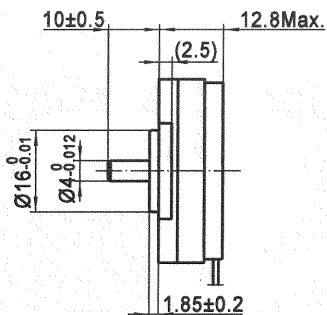
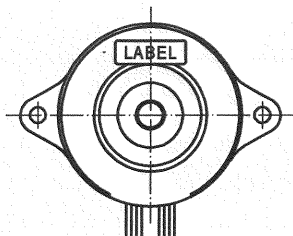
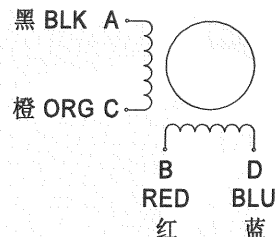

连接器针位 vs. 引线颜色  
Pin No. vs. Lead Wire Colour

PIN No.	颜色 Colour
1	黑 BLK
2	橙 ORG
3	红 RED
4	蓝 BLU

励磁顺序 vs. 旋转方向  
Exciting Sequence vs. Direction of Rotation

STEP	A	B	C	D	
1	+	+	-	-	CCW ↑ CW
2	-	+	+	-	
3	-	-	+	+	
4	+	-	-	+	

从安装面看为顺时针方向  
Clockwise view from mounting side

规格 Specifications

1. 相数 Number of Phase	2
2. 步距角 Step Angle	0.9°
3. 额定电压 Rated Voltage	4.8V DC
4. 额定电流 Rated Current	0.3Amp
5. 保持力矩 Holding Torque	44mNm Typ. (Two phase on/rated current)
6. 相电阻 Phase Resistance	16ohm±10% (20°C)
7. 相电感 Phase Inductance	8.8mH±20% (1kHz 1V rms)
8. 转子惯量 Rotor Inertia	4gcm <sup>2</sup>
9. 电机重量 Motor Weight	60g
10. 绝缘等级 Insulation Class	B(130°C)

铭牌 Label Detail

MOONS' STEPPING MOTOR  
TYPE 14HK0405-13N  
XXXXXXXX YY/MM/DD

Work Order 加工单号  
Date Format 日期格式

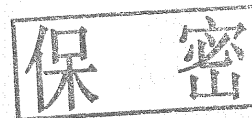

REV.	版本记录 REVISION RECORD	DATE	UNLESS OTHERWISE SPECIFIED	NAMES	SIGNATURE	DATE	Type: 14HK0405-13N	Rev.B	SCALE 1:1	Sheet 1 of 1
B	尺寸 200±10, (80)	2019.02.20	△				MOONS' Shanghai Moons' Electric Co., Ltd.	Hybrid Stepping Motor		
A	原始版本 Original revision	2018.10.08								
Unit: mm 第一角画法 FIRST ANGLE METHOD 未注线性与角度尺寸公差 Tolerances for linear and angular dimensions without individual tolerance indications GB/T 1804-m eqv ISO 2768-1 : m 未注形状与位置尺寸公差 Geometrical tolerance for features without individual tolerance indications GB/T 1184-K eqv ISO 2768-2 : K				批准 Approve			This document is released for information only. Its reproduction in whole or in part or its dissemination to third parties is prohibited. All trademarks and registered trademarks appearing on this document are the property of their respective owners.			
				标准化 Standard						
				工艺 Technology						
				审核 Check						
				设计 Design	石惠英	2019.02.20				