

CABLE SPECIFICATION

CONDUCTOR:
 MATERIAL: TINED COPPER
 SECTION: 26AWG
 INSULATION:
 COMPOUND: POLYOLEFIN
 JACKET:
 COMPOUND: PVC
 COLOR: TEAL
 NOM. DIAMETER: 5.99mm
 TEMPERATURE RATING:
 -20°C TO +75°C
 VOLTAGE RATING MAX: 300V RMS
 DIELECTRIC WITHSTANDING MIN: 1500V RMS

PART No MATRIX

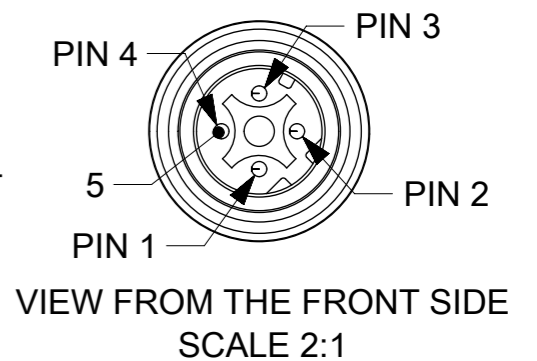
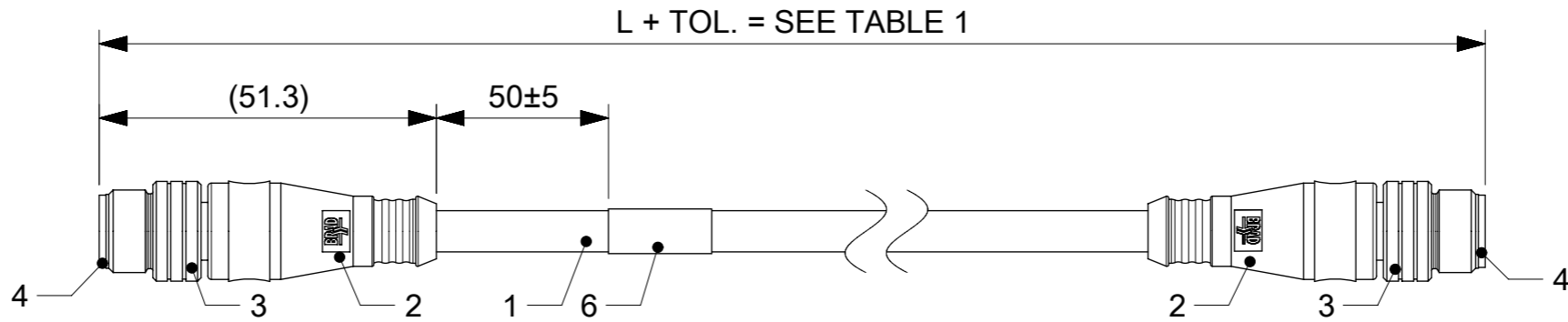
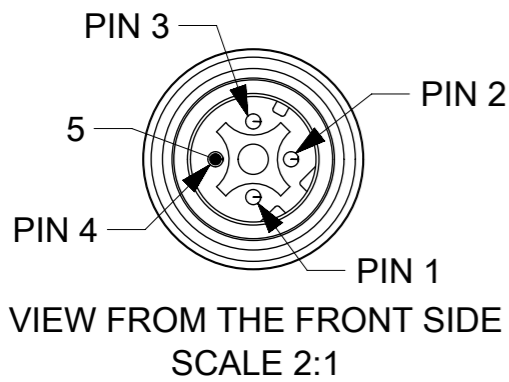
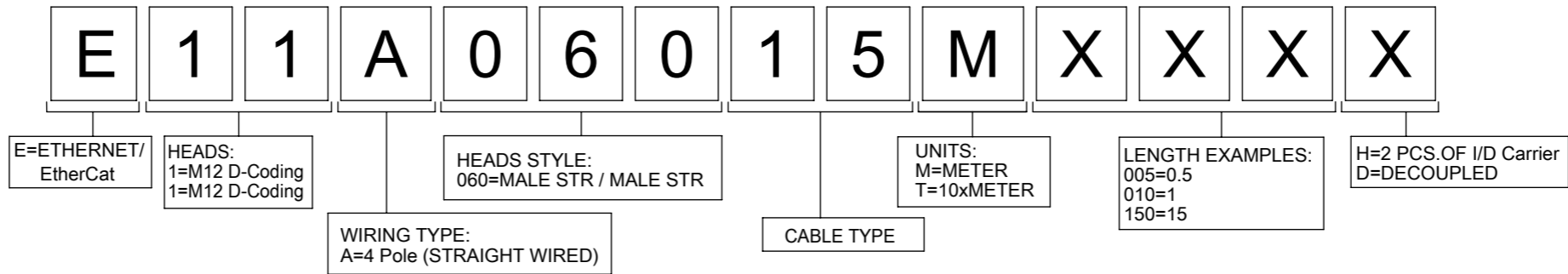

WIRING DIAGRAM

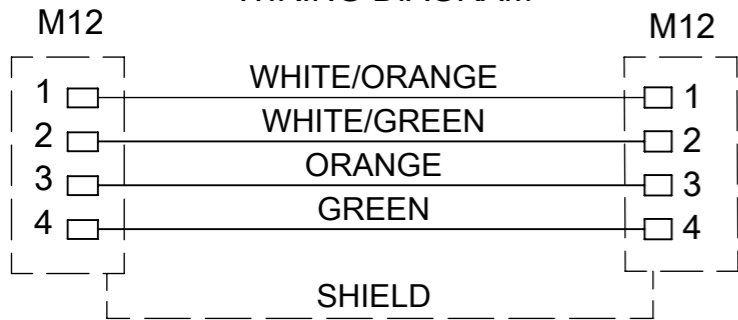

OVER	UP TO AND INCLUDING	TOLERANCE (+)
0	305	+19
305	915	+45
915	1830	+56
1830	3660	+89
3660	7320	+165
7320	14640	+317
14640	30500	+610
30500	>	+2% OF LENGTH

BILL OF MATERIALS

ITEM	QTY.	DESCRIPTION	MATERIAL	FINISH
6	1	LABEL WH	-	-
5	8	CONTACT MA	COPPER ALLOY	GOLD OVER NICKEL
4	2	INSERT MA 4P DC BK	PUR	-
3	2	COUPLING NUT	BRASS	NICKEL
2	-	MOULDING MATERIAL BK	TBU	-
1	-	CABLE 4x26AWG CAT5E TEAL	PVC	-

TABLE 1

MOLEX PN	ENGINEERING No	L [mm]	MOLEX PN	ENGINEERING No	L [mm]	MOLEX PN	ENGINEERING No	L [mm]
1300480009	E11A06015M030	3000	1300488109	E11A06015M800	80000	1300488165	E11A06015M420	42000
1300480010	E11A06015M200	20000	1300488113	E11A06015M350	35000	1300488166	E11A06015M450	45000
1300480011	E11A06015M400	40000	1300488125	E11A06015M110	11000	1300488167	E11A06015M460	46000
1300480122	E11A06015M010	1000	1300488126	E11A06015M120	12000	1300488168	E11A06015M540	54000
1300480123	E11A06015M010D	1000	1300488127	E11A06015M140	14000	1300488169	E11A06015M550	55000
1300480124	E11A06015M020	2000	1300488128	E11A06015M060	6000	1300488170	E11A06015M570	57000
1300480125	E11A06015M020D	2000	1300488145	E11A06015M070	7000	1300488171	E11A06015M610	61000
1300480126	E11A06015M050	5000	1300488146	E11A06015M080	8000	1300488172	E11A06015M650	65000
1300480128	E11A06015M100	10000	1300488147	E11A06015M090	9000	1300488173	E11A06015M700	70000
1300480130	E11A06015M150	15000	1300488148	E11A06015M130	13000	1300488174	E11A06015M750	75000
1300480132	E11A06015M300	30000	1300488159	E11A06015M005	500	1300488175	E11A06015M850	85000
1300480303	E11A06015M500	50000	1300488160	E11A06015M180	18000	1300488176	E11A06015M900	90000
1300480304	E11A06015M680	68000	1300488161	E11A06015M230	23000	1300488177	E11A06015M950	95000
1300488007	E11A06015M250	25000	1300488162	E11A06015M270	27000	1300480120	E11A06015M006	600
1300488012	E11A06015M400	4000	1300488163	E11A06015M340	34000	1300488210	E11A06015M003	300
1300488108	E11A06015M600	60000	1300488164	E11A06015M380	38000			

SYMBOLS DIMENSION UNITS: mm SCALE: 2:1 GENERAL TOLERANCES (UNLESS SPECIFIED) ANGULAR TOL ± ° 4 PLACES ± 3 PLACES ± 2 PLACES ± 1 PLACE ± 0 PLACES ± DRAFT WHERE APPLICABLE MUST REMAIN WITHIN DIMENSIONS THIRD ANGLE PROJECTION	THIS DRAWING CONTAINS INFORMATION THAT IS PROPRIETARY TO MOLEX ELECTRONIC TECHNOLOGIES, LLC AND SHOULD NOT BE USED WITHOUT WRITTEN PERMISSION CURRENT REV DESC:				
	EC NO: 625781 DRWN: AKONDRACIUK 2019/10/16 CHK'D: DSTACHOWIAK 2019/10/16 APPR: DSTACHOWIAK 2019/10/16				CSE M12 ETH 4P DC MA MA STR PVC XM DE
	INITIAL REVISION: DRWN: DSTACHOWIAK 2017/06/26 APPR: MIWASIECZKO 2017/06/28		PRODUCT CUSTOMER DRAWING		
	MUST REMAIN WITHIN DIMENSIONS		DOCUMENT NUMBER: 1300488146	DOC TYPE: PSD	DOC PART: 000
A3-SIZE		SERIES: 130048	MATERIAL NUMBER: SEE TABLE 1	CUSTOMER: GENERAL MARKET	SHEET NUMBER: 1 OF 1

6

5

4

3

2

1

PART NUMBER	ENGINEERING NO.	LENGTH ± TOLERANCE
1300480122	E11A06015M010	3' 3" +2.19"/-0" [1M +55.6/-0 mm]
1300480126	E11A06015M050	16' 4" +6.5"/-0" [5M +165.0/-0 mm]

AUX VIEW
SCALE 1:4

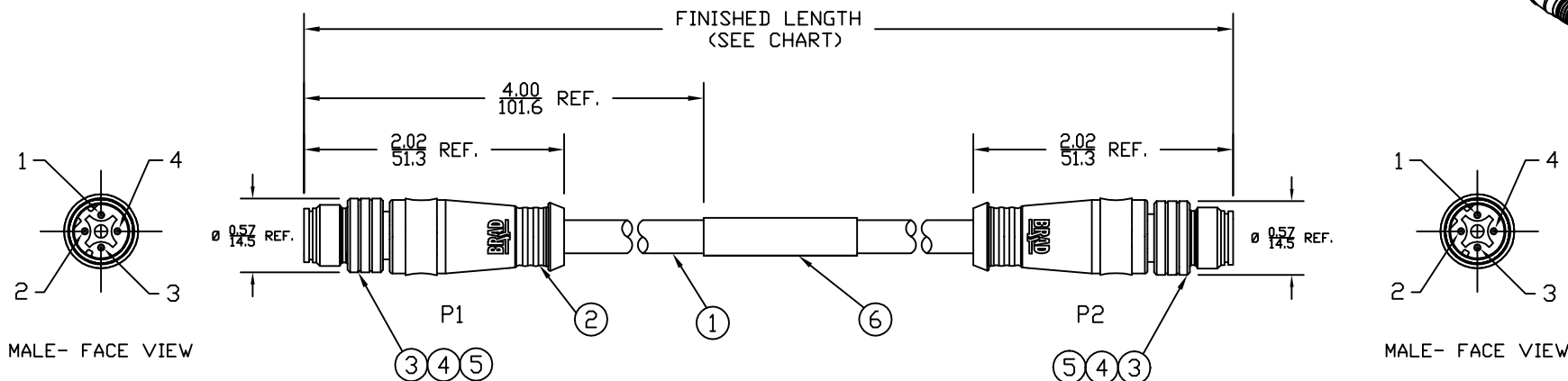
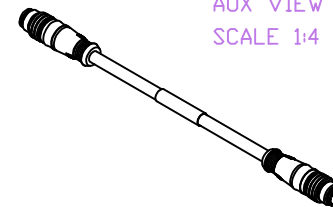

P1		P2	
1	WHITE/DRG	1	
2	WHITE/GRN	2	
3	ORANGE	3	
4	GREEN	4	

WIRING DIAGRAM

NOTES:

- MATERIAL: SEE TABLE
- FINISHES: SEE TABLE
- CABLE: #26/4 SHIELDED PVC
- ELECTRICAL DATA:
ACCORDING TO CAT5e ETHERNET STANDARD
MAX. VOLTAGE: 30V
MAX. CURRENT: 1.5A
- ENVIRONMENTAL:
PROTECTION IP67
TEMPERATURE RANGE: -20°C TO 75°C
- WRAP LABEL IS MARKED WITH P/N, DATE CODE,
VOLTAGE & AMPERAGE.
- ASSEMBLY IS RoHS COMPLIANT.

ITEM	QTY.	DESCRIPTION	MATERIAL	FINISH
6	1	LABEL	PLASTIC FILM	BLACK/YELLOW
5	2	INSERT	PUR	BLACK
4	8	PIN CONTACT	COPPER ALLOY	GOLD PLATED
3	2	M12 COUPLING NUT	BRASS	NICKEL
2	2	OVERMOLD	PUR	BLACK
1	1	ETHERNET CABLE-CAT5E	PVC JACKET	TEAL

SD RELEASE EC NO: WEL2010-0005 7/13/09 DRWN: VOU CHKD: BWOODMAN APPR: JFMURPHY 2009/07/20	QUALITY SYMBOLS ▽=0 ▽=0	GENERAL TOLERANCES (UNLESS SPECIFIED)		DIMENSION STYLE	SCALE	DESIGN UNITS	THIRD ANGLE PROJECTION	
				IN/MM	3:4	INCH		
		4 PLACES	±----	±----	DRAWN BY	DATE		TITLE
		3 PLACES	±----	±.005	VOU	2009/07/06		MICRO-CHANGE CABLE ASSY 4P M/MP ST/ST D-CODE #26/4 SHIELDED PVC
2 PLACES	±----	±.010	CHECKED BY	DATE				
1 PLACE	±----	±.020	BWOODMAN	2009/07/31				
		ANGULAR ± 1/2°		APPROVED BY	DATE			
DRAFT WHERE APPLICABLE MUST REMAIN WITHIN DIMENSIONS		SEE CHART		MATERIAL NO.	DOCUMENT NO.	SHEET NO.		
				SIZE	THIS DRAWING CONTAINS INFORMATION THAT IS PROPRIETARY TO MOLEX INCORPORATED AND SHOULD NOT BE USED WITHOUT WRITTEN PERMISSION			
				A	SD-120108-020			
							1 OF 1	

6

5

4

3

2

1