



PRODUCT SPECIFICATION

LOW PROFILE RIGHT ANGLE MODULAR JACKS

1.0 SCOPE

This Product Specification covers the 1.27 mm (.050 inch) centerline (pitch) printed circuit board (PCB) modular jack connector series with selective gold and tin plating.

2.0 PRODUCT DESCRIPTION

2.1 PRODUCT NAME AND SERIES NUMBER(S)

Low Profile Right Angle Modular Jacks 43223

2.2 DIMENSIONS, MATERIALS, PLATINGS AND MARKINGS

See the appropriate sales drawings (SDA-43223) for information on dimensions, materials, plating and markings.

2.3 SAFETY AGENCY APPROVALS

UL File Number.....E107635
CSA File Number.....LR19980

3.0 REFERENCE DOCUMENTS

FCC Rules and Regulations, Part 68, Subpart F
REA Bulletin 345-81, PE-76; Specification for modular telephone set hardware
ANSI/EIA/TIA-568
IEC-60603-7
UL 1863
MIL-STD-202; General requirements for test specifications

4.0 RATINGS

4.1 VOLTAGE

56.5 V DC
150 V_{RMS} AC (Ringing voltage only)

4.2 CURRENT

1.5 Amps @ 25°C

4.3 TEMPERATURE

Operating: - 40°C to + 85°C
Nonoperating:* - 40°C to + 85°C
*Packaging materials should not exceed + 50°C

REVISION: C1	EGR/ECN INFORMATION: EC No: UCP2008-0143 DATE: 8/3/2007	TITLE: PRODUCT SPECIFICATION LOW PROFILE RIGHT ANGLE MODULAR JACKS	SHEET No. 1 of 5
DOCUMENT NUMBER: PS-43223-001	CREATED / REVISED BY: JBELL 7/23/2007	CHECKED BY: LSCHMIDT 7/24/2007	APPROVED BY: FSMITH 7/25/2007



PRODUCT SPECIFICATION

5.0 PERFORMANCE

5.1 ELECTRICAL REQUIREMENTS

	DESCRIPTION	TEST CONDITION	REQUIREMENT
	Contact Resistance (Low Level)	Mate connectors: apply a maximum voltage of 20 mV and a current of 15 mA . (Measurement locations in Section 7.0)	10 milliohms MAXIMUM [initial]
	Insulation Resistance	Unmated connector, mounted to a PCB: apply a voltage of 500 VDC between adjacent terminals and between terminals to ground.	500 Megohms MINIMUM
	Dielectric Withstanding Voltage	Mate connectors: apply a voltage of 1000 VAC for 1 minute between adjacent terminals and between terminals to ground.	No breakdown; current leakage < 5 mA
	Temperature Rise	Mate connectors: measure the temperature rise at the rated current after: 96 hours	Temperature rise; +30°C MAXIMUM

REVISION: C1	EGR/ECN INFORMATION: EC No: UCP2008-0143 DATE: 8/3/2007	TITLE: PRODUCT SPECIFICATION LOW PROFILE RIGHT ANGLE MODULAR JACKS	SHEET No. 2 of 5
DOCUMENT NUMBER: PS-43223-001	CREATED / REVISED BY: JBELL 7/23/2007	CHECKED BY: LSCHMIDT 7/24/2007	APPROVED BY: FSMITH 7/25/2007



PRODUCT SPECIFICATION

5.2 MECHANICAL REQUIREMENTS

	DESCRIPTION	TEST CONDITION	REQUIREMENT
	Connector Mate Force	Mate connector at a rate of 25 ± 6 mm (1 ± ¼ inch) per minute. (Gage dimensions in Section 7.0)	22 N (5 lbf) MAXIMUM insertion force
	Durability	Mate connectors up to 500 cycles at a maximum rate of 20 cycles per minute prior to Environmental Tests.	10 milliohms MAXIMUM (change from initial)
	Vibration (Random)	Mate connectors and vibrate per MIL-STD-202	10 milliohms MAXIMUM (change from initial) & Discontinuity < 1 microsecond
	Plug Retention Force	Apply an axial pullout force on the plug at a rate of 25 ± 6 mm (1 ± ¼ inch) per minute.	89 N (20 lbf) MINIMUM retention force
	PCB Separation Forces	Apply a perpendicular load on the plug at a rate of 25 ± 6 mm (1 ± ¼ inch) per minute.	4.5 N (1 lbf) MINIMUM withdrawal force before solder reflow 89 N (20 lbf) MINIMUM withdrawal force after solder reflow

REVISION: C1	EGR/ECN INFORMATION: EC No: UCP2008-0143 DATE: 8/3/2007	TITLE: PRODUCT SPECIFICATION LOW PROFILE RIGHT ANGLE MODULAR JACKS	SHEET No. 3 of 5
DOCUMENT NUMBER: PS-43223-001	CREATED / REVISED BY: JBELL 7/23/2007	CHECKED BY: LSCHMIDT 7/24/2007	APPROVED BY: FSMITH 7/25/2007



PRODUCT SPECIFICATION

5.3 ENVIRONMENTAL REQUIREMENTS

	DESCRIPTION	TEST CONDITION	REQUIREMENT												
	Thermal (Cycling)	Connectors to be placed in 95% relative humidity. Maximum temperature change is 15°C/hour . Cycle linearly per chart below. Mate connectors; expose to 10 cycles of: <table border="1"> <thead> <tr> <th>Temperature °C</th> <th>Duration (Minutes)</th> </tr> </thead> <tbody> <tr> <td>30 to 5</td> <td>120</td> </tr> <tr> <td>5 to 30</td> <td>120</td> </tr> <tr> <td>Hold at 30</td> <td>240</td> </tr> <tr> <td>30 to 5</td> <td>180</td> </tr> <tr> <td>Hold at 5</td> <td>180</td> </tr> </tbody> </table>	Temperature °C	Duration (Minutes)	30 to 5	120	5 to 30	120	Hold at 30	240	30 to 5	180	Hold at 5	180	10 milliohms MAXIMUM (change from initial) & Dielectric Withstanding Voltage: No Breakdown at 500 VAC & Insulation Resistance: 500 Megohms MINIMUM & Visual: No Damage
Temperature °C	Duration (Minutes)														
30 to 5	120														
5 to 30	120														
Hold at 30	240														
30 to 5	180														
Hold at 5	180														
	Solderability	Dip solder tails in flux and immerse in solder Bath at 260±5°C for 5±0.5 seconds	Solder Wetting Visual: 95% of immersed area must show no voids, pin holes												

REVISION: C1	EGR/ECN INFORMATION: EC No: UCP2008-0143 DATE: 8/3/2007	TITLE: PRODUCT SPECIFICATION LOW PROFILE RIGHT ANGLE MODULAR JACKS	SHEET No. 4 of 5
DOCUMENT NUMBER: PS-43223-001	CREATED / REVISED BY: JBELL 7/23/2007	CHECKED BY: LSCHMIDT 7/24/2007	APPROVED BY: FSMITH 7/25/2007



PRODUCT SPECIFICATION

6.0 PACKAGING

Parts shall be packaged to protect against damage during handling, transit and storage. See appropriate sales drawings on Sheet 1 for packaging descriptions.

7.0 GAGES AND FIXTURES

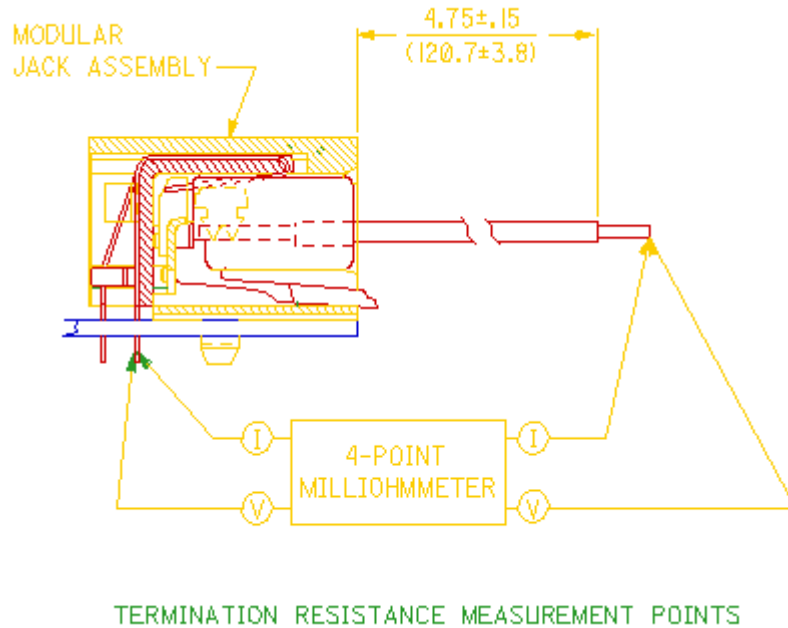

8.0 OTHER INFORMATION

REVISION: C1	EGR/ECN INFORMATION: EC No: UCP2008-0143 DATE: 8/3/2007	TITLE: PRODUCT SPECIFICATION LOW PROFILE RIGHT ANGLE MODULAR JACKS	SHEET No. 5 of 5
DOCUMENT NUMBER: PS-43223-001	CREATED / REVISED BY: JBELL 7/23/2007	CHECKED BY: LSCHMIDT 7/24/2007	APPROVED BY: FSMITH 7/25/2007