

13 12 11 10 9 8 7 6 5 4 3 2 1

J  
I  
H  
G  
F  
E  
D  
C  
B  
A

J  
I  
H  
G  
F  
E  
D  
C  
B  
A

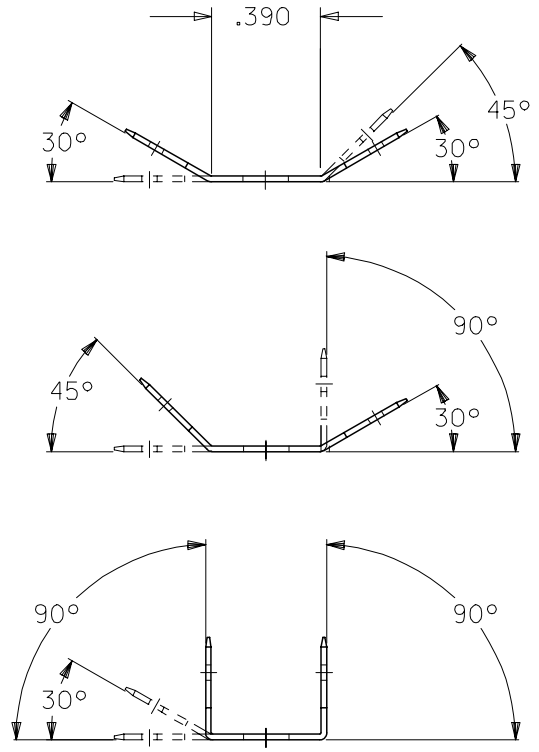
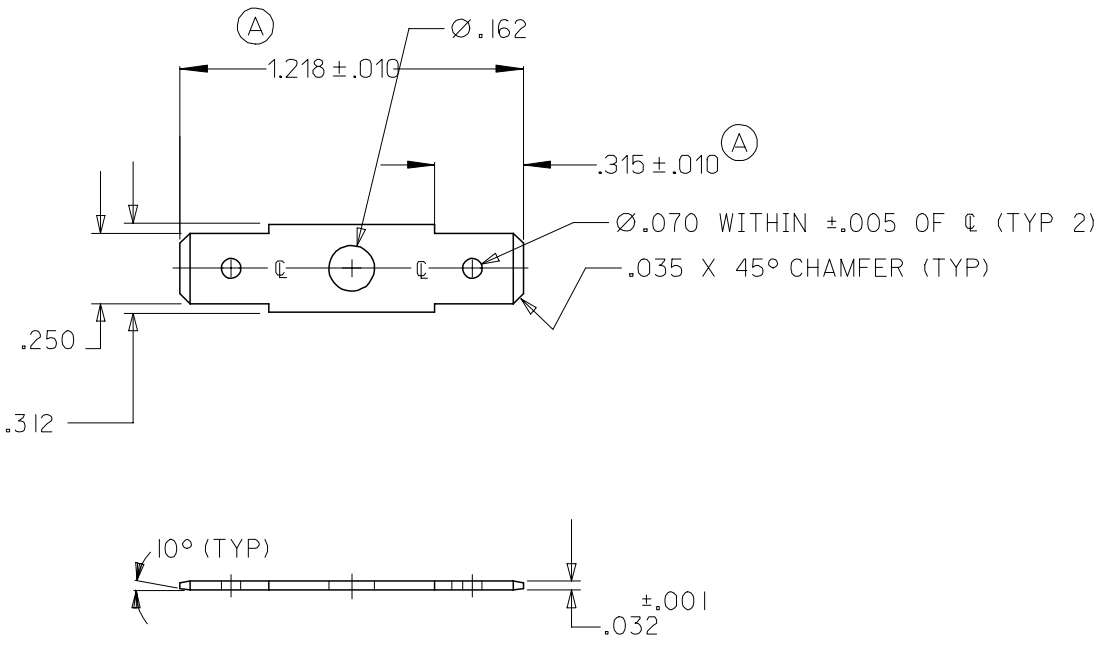

NOTES:  
 1. MATERIAL: BRASS  
 PLATING: ELECTRO-TIN  
 2. TOLERANCE ON ALL ANGLES IS ± 2.5°

PART NO.	ANGLE COMBINATIONS	
3520	0°	0°
3521	30°	30°
3522	45°	45°
3523	90°	90°
3524	0°	30°
3525	0°	45°
3526	0°	90°
3527	30°	90°
3528	45°	90°

ADDED TOLERANCES EC NO: ETC2006-0370 DRW:NASAYDEH 2006/04/12 CHKD:RDEROSS 2006/04/17 APPR:RDEROSS 2006/04/18 REV: A	QUALITY SYMBOLS ▽=0 ▽=0	GENERAL TOLERANCES (UNLESS SPECIFIED)		DIMENSION STYLE IN/MM		SCALE 4:1	DESIGN UNITS INCH	THIRD ANGLE PROJECTION
		4 PLACES ± --- ± --- 3 PLACES ± --- ± .005 2 PLACES ± 0.13 ± .010 1 PLACE ± 0.25 ± --- ANGULAR ± ---°	DRAWN BY RCM	DATE 72/12/20	TITLE DOUBLE END MALE Q.D. TAB .250 X .032			
			CHECKED BY JM	DATE 72/12/20	MOLEX INCORPORATED			
			APPROVED BY FP	DATE 72/12/20	MATERIAL NO. SEE CHART	DOCUMENT NO. SD-19163-005	SHEET NO. 1 OF 1	

12 11 10 9 8 7 6 5 4 3 2 1