



UM9301/UM9301SM

Commercial Attenuator Diode

PRODUCT PREVIEW

DESCRIPTION

The UM9301 PIN Diode utilizes special overall chip geometry with an extremely thick intrinsic "I" region, to offer unique capabilities in both RF switch and attenuator applications. Volume production also makes the diode an economical choice suitable for many commercial low power equipments. The UM9301 has been designed for use in bridged TEE attenuator circuits commonly utilized for gain and slope control in CATV amplifiers.

Low distortion and high dynamic range are characteristic of the diodes' outstanding performance.

The UM9301 is also appropriate for switch applications, when little or no bias voltage is available. Frequent applications occur in portable 12 volt-powered communications equipments, operating at frequencies as low as 2 MHz.

KEY FEATURES

- Specified low distortion
- Low distortion properties at low reverse bias
- Resistance specified at 3 current points
- High reliability fused-in-glass construction

APPLICATIONS/BENEFITS

- Little or no Bias required.
- Operates as low as 2MHz.
- Available in leaded or surface mount packages.

IMPORTANT: For the most current data, consult MICROSEMI's website: <http://www.microsemi.com>

ABSOLUTE MAXIMUM RATINGS AT 25° C (UNLESS OTHERWISE SPECIFIED)

Rating	Symbol	Value	Unit
Reverse Voltage	V_R	75	Volts
Reverse Current	I_R	10	μA
Average Power Dissipation (1, 2)	P_A	1.0	Watts
Storage Temperature	T stg	-65 to 175	°C
Operating Temperature	T op	-65 to 175	°C

UM9301SM

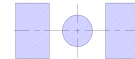

UM9301

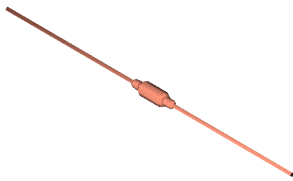

UM9301SM

- (1) Mounted on 2" square by 0.06" thick FR4 board with a 1" x 1" square 2-ounce copper pattern..
(2) Lead 1/2 inch. (12.7mm) Total to 25°C Contact.



ELECTRICAL PARAMETERS @ 25°C (unless otherwise specified)						
Parameter	Symbol	Conditions	Min	Typ.	Max	Units
▶ Off Characteristics						
Diode Resistance	R_S	$I = 100 \text{ mA}; f = 100 \text{ MHz}$ $I = 1 \text{ mA}; f = 100 \text{ MHz}$ $I = 0.01 \text{ mA}; f = 100 \text{ MHz}$	3000	1.7 80 5000	3.0 150	Ω
Current for $R_S = 75 \Omega I_R$	R_S	$f = 100 \text{ MHz}$	0.5	1.1	2.0	mA
Return Loss	I	Frequency Range: 10-300MHz $R_S = 75 \Omega @ 100\text{MHz}$ Diode Terminates 75Ω line	25			dB
Second Order Distortion	V	$f_1 = 10 \text{ MHz}; f_2 = 13 \text{ MHz}$ $P = 50 \text{ dBmV}; \text{ See Test Circuit}$		55	50	-dB
		$F_1 = 67 \text{ MHz}; f_2 = 77 \text{ MHz}$ $P = 50 \text{ dBmV}; \text{ See Test Circuit}$		70		-dB
Third Order Distortion	V	$F_1 = 10 \text{ MHz}; F_2 = 13 \text{ MHz}$ $P = 50 \text{ dBmV}; \text{ See Test Circuit}$		75	65	-dB
		Triple Beat; 205 +67 -77MHz $P = 50 \text{ dBmV}; \text{ See Test Circuit}$		95		-dB
Cross Modulation Distortion	V	12 Channel Test $P = 50 \text{ dBmV}; \text{ See Test Circuit}$ Dix Hills Test Set		75		-dB
Reverse Current	I_R	$V = 75 \text{ V}$			10	μA
Carrier Lifetime	τ	$I = 10 \text{ mA}$	4.0			μs
▶ Dynamic characteristics						
Capacitance	C_T	$V = 0\text{V}; f = 100 \text{ MHz}$			0.8	pF

FORWARD CURRENT VS FORWARD VOLTAGE (TYPICAL)

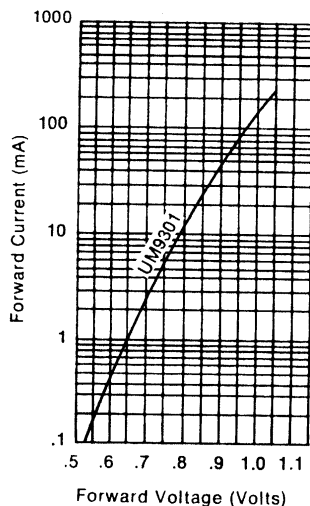

DIODE RESISTANCE VS DIODE CURRENT (TYPICAL)

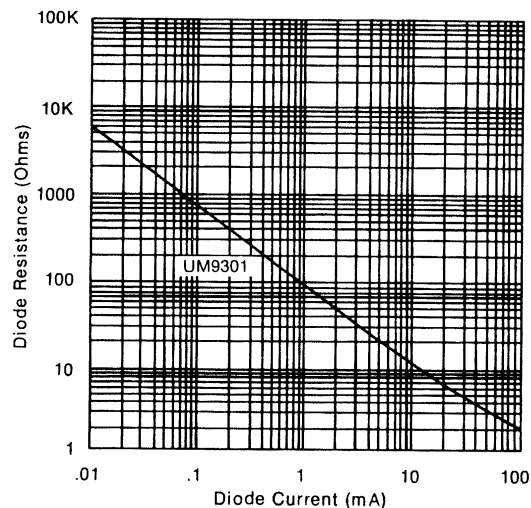

PRODUCT PRELIMINARY DATA – Information contained in this document is pre-production data, and is proprietary to Microsemi Corp. It may not be modified in any way without the express written consent of Microsemi Corp. Product referred to herein is not guaranteed to achieve preliminary or production status and product specifications, configurations, and availability may change at any time.

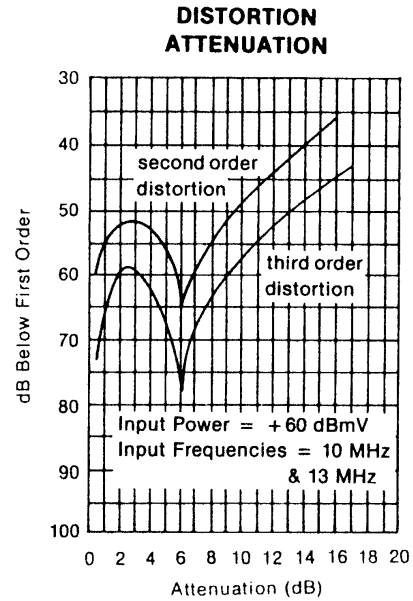
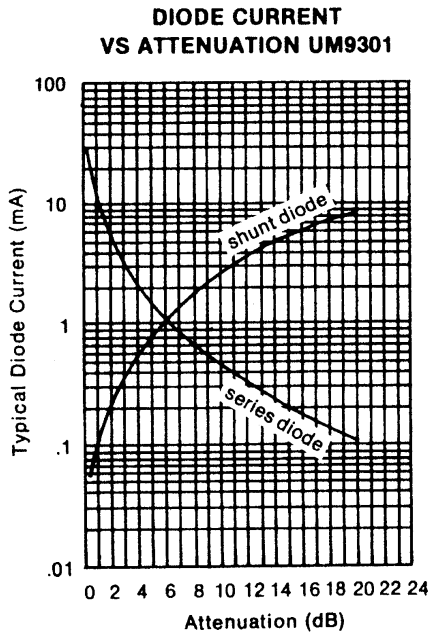
TYPICAL BRIDGED TEE ATTENUATOR PERFORMANCE

TEST CIRCUIT FOR DISTORTION MEASUREMENTS D.U.T.

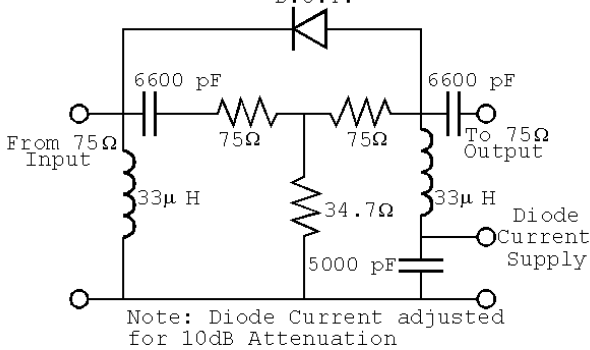

NORMALIZED R_S VS TEMPERATURE

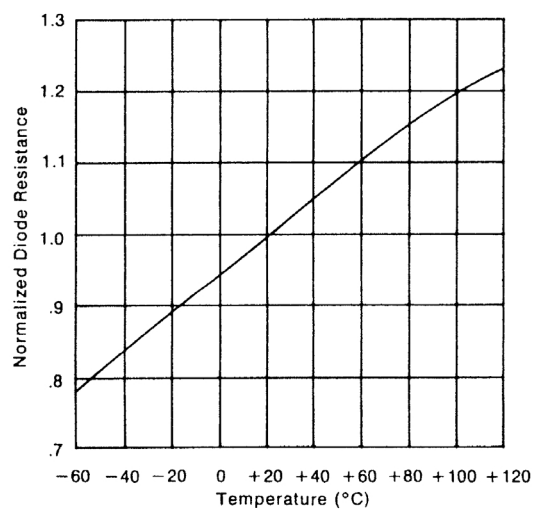

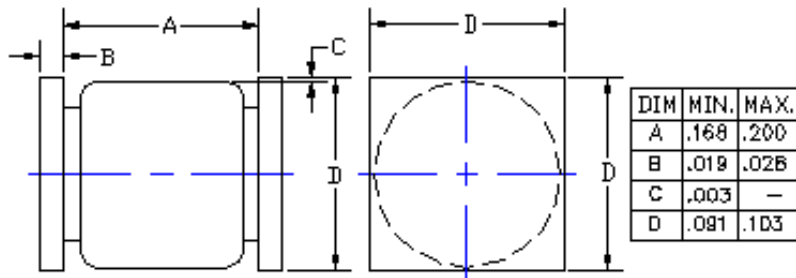
UM9301SM

NOTES:

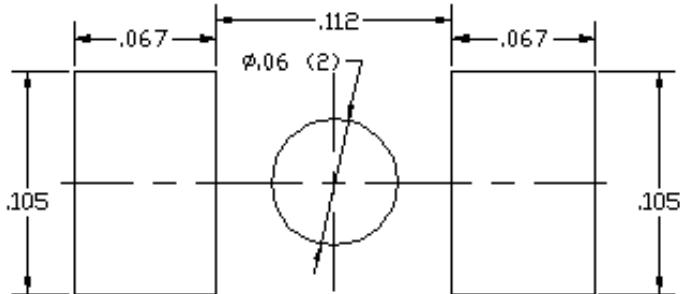
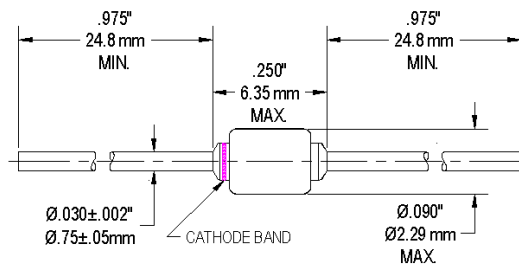
1. These dimensions will match the terminals and provide for additional solder fillets at the outboard ends at least as wide as the terminals themselves, assuming accuracy of device placement within .005 inches.
2. If the mounting method chosen requires use of an adhesive separate from the solder compound, a round (or square) spot of cement as shown should be satorially located.
3. Dimensions shown are in inches.

STANDARD SM ALL SQUARE END CAP OUTLINE

UM9301

NOTES:

1. BAND INDICATE CATHODE END.



UM9301/UM9301SM

Commercial Attenuator Diode

PRODUCT PREVIEW