



# 8-Port, 36V Constant-Current LED Driver with LED Fault Detection

MAX6981

## General Description

The MAX6981 serial-interfaced LED driver provides eight open-drain, constant-current-sinking LED driver outputs rated at 36V. The device operates from a 3V to 5.5V supply. The MAX6981 supply and the LEDs' supply can power up in any order. The constant-current outputs are programmed together up to 55mA using a single external resistor. The MAX6981 operates with a 25Mbps, industry-standard, 4-wire serial interface.

The MAX6981 includes circuitry that automatically detects open-circuit LEDs. Fault status is loaded into the serial-interface shift register when LE goes high and is automatically shifted out on DOUT when the next data transmission is shifted in.

The MAX6981 uses the industry-standard shift-register-plus-latch-type serial interface. The driver accepts data shifted into an 8-bit shift register using data input DIN and clock input CLK. Input data appears at output DOUT eight clock cycles later to allow cascading of multiple MAX6981s. The latch-enable input, LE, loads the 8 bits of shift register data into an 8-bit output latch to set which LEDs are on and which are off. The output-enable input,  $\overline{OE}$ , gates all eight outputs on and off, and is fast enough to be used as a PWM input for LED intensity control.

The MAX6981 is one of a family of 10 shift-register-plus-latch-type LED drivers. The family includes 8-port and 16-port types, with 5.5V- or 36V-rated LED outputs, with and without open-circuit LED detection and watchdog. All versions operate from a 3V to 5.5V supply, and are specified over the  $-40^{\circ}\text{C}$  to  $+125^{\circ}\text{C}$  temperature range.

## Applications

- Variable Message Signs
- Marquee Displays
- Point-of-Order Signs
- Traffic Signs
- Gaming Features
- Architectural Lighting

## Features

- ◆ 25Mbps Industry-Standard 4-Wire Serial Interface at 5V
- ◆ 3V to 5.5V Logic Supply
- ◆ Eight Constant-Current LED Outputs Rated at 36V
- ◆ Up to 55mA Continuous Current per Output
- ◆ Output Current Programmed by Single Resistor
- ◆ 3% Current Matching Between Outputs
- ◆ 6% Current Matching Between ICs
- ◆ Reports Open-Circuit LED Faults
- ◆  $-40^{\circ}\text{C}$  to  $+125^{\circ}\text{C}$  Temperature Range

## Ordering Information

PART	TEMP RANGE	PIN-PACKAGE	PKG CODE
MAX6981AUE	$-40^{\circ}\text{C}$ to $+125^{\circ}\text{C}$	16 TSSOP-EP*	U16E-3
MAX6981APE	$-40^{\circ}\text{C}$ to $+125^{\circ}\text{C}$	16 PDIP	A16-2
MAX6981AAE	$-40^{\circ}\text{C}$ to $+125^{\circ}\text{C}$	16 SSOP	P16-1

\*EP = Exposed pad.

Typical Application Circuit and Selector Guide appear at end of data sheet.

## Pin Configuration

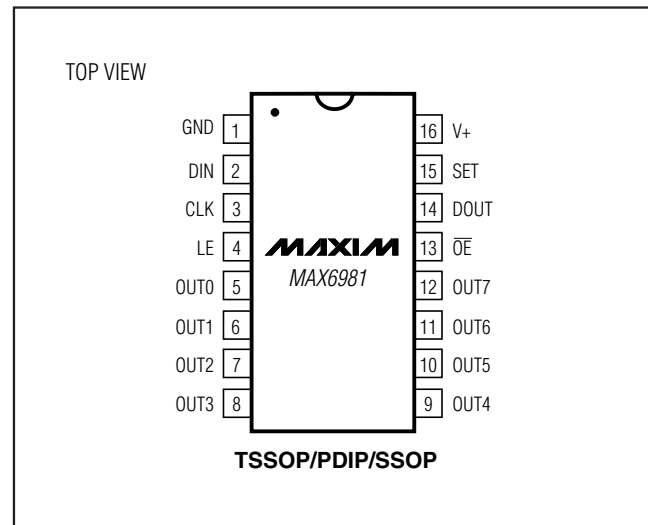

# 8-Port, 36V Constant-Current LED Driver with LED Fault Detection

## ABSOLUTE MAXIMUM RATINGS

(Voltage with respect to GND.)

V+	-0.3V to +6V
OUT <sub>-</sub>	-0.3V to +40V
DIN, CLK, LE, $\overline{OE}$ , SET	-0.3V to (V+ + 0.3V)
DOUT Current	±10mA
OUT <sub>-</sub> Sink Current	.60mA
Total GND Current	480mA

Continuous Power Dissipation (T<sub>A</sub> = +70°C)

16-Pin TSSOP-EP (derate 21.3mW/°C above +70°C)	..1702mW
16-Pin PDIP (derate 10.5mW/°C above +70°C)	.....842mW
16-Pin SSOP (derate 7.1mW/°C above +70°C)	.....571mW
Operating Temperature Range	.....-40°C to +125°C
Junction Temperature	.....+150°C
Storage Temperature Range	.....-65°C to +150°C
Lead Temperature (soldering, 10s)	.....+300°C

Stresses beyond those listed under "Absolute Maximum Ratings" may cause permanent damage to the device. These are stress ratings only, and functional operation of the device at these or any other conditions beyond those indicated in the operational sections of the specifications is not implied. Exposure to absolute maximum rating conditions for extended periods may affect device reliability.

## ELECTRICAL CHARACTERISTICS

(Typical Operating Circuit, V+ = 3V to 5.5V, T<sub>A</sub> = T<sub>MIN</sub> to T<sub>MAX</sub>, unless otherwise noted. Typical values are at V+ = 5V, T<sub>A</sub> = +25°C.)  
(Note 1)

PARAMETER	SYMBOL	CONDITIONS	MIN	TYP	MAX	UNITS
Operating Supply Voltage	V+		3.0		5.5	V
Output Voltage	V <sub>OUT</sub>				36	V
Standby Current (Interface Idle, All Output Ports High Impedance, R <sub>SET</sub> = 360Ω)	I <sub>+</sub>	All logic inputs at V+ or GND, DOUT unloaded		3.6	5.6	mA
Standby Current (Interface Running, All Output Ports High Impedance, R <sub>SET</sub> = 360Ω)	I <sub>+</sub>	f <sub>CLK</sub> = 5MHz, $\overline{OE}$ = V+, DIN and LE = V+ or GND, DOUT unloaded		3.8	6.0	mA
Supply Current (All Output Ports Active Low, R <sub>SET</sub> = 360Ω)	I <sub>+</sub>	f <sub>CLK</sub> = 5MHz, $\overline{OE}$ = GND, LE and DIN = V+, DOUT unloaded		17	30	mA
Input High Voltage DIN, CLK, LE, $\overline{OE}$	V <sub>IH</sub>		0.7 x V+			V
Input Low Voltage DIN, CLK, LE, $\overline{OE}$	V <sub>IL</sub>				0.3 x V+	V
Hysteresis Voltage DIN, CLK, LE, $\overline{OE}$	ΔV <sub>I</sub>			0.8		V
Input Leakage Current DIN, CLK, LE, $\overline{OE}$	I <sub>IH</sub> , I <sub>IL</sub>		-1		+1	μA
Pullup Resistor to V+, $\overline{OE}$	R <sub>OE</sub>		0.170	3	10.000	MΩ
Pullup Resistor to GND, LE	R <sub>LE</sub>		0.170	3	10.000	MΩ
Output High Voltage DOUT	V <sub>OH</sub>	I <sub>SOURCE</sub> = 4mA	V+ - 0.5V			V
Output Low Voltage	V <sub>OL</sub>	I <sub>SINK</sub> = 4mA			0.5	V
Output Current OUT <sub>-</sub>	I <sub>OUT</sub>	V+ = 3.0V to 5.5V, V <sub>OUT</sub> = 0.8V to 2.5V, R <sub>SET</sub> = 360Ω	36	50	60	mA
Output Leakage Current OUT <sub>-</sub>	I <sub>LEAK</sub>	$\overline{OE}$ = V+			1	μA
Watchdog Timeout	t <sub>WD</sub>		0.1	1	2.5	s

# 8-Port, 36V Constant-Current LED Driver with LED Fault Detection

MAX6981

## 5V TIMING CHARACTERISTICS

(Typical Operating Circuit,  $V_+ = 4.5V$  to  $5.5V$ ,  $T_A = T_{MIN}$  to  $T_{MAX}$ , unless otherwise noted.) (Notes 1, 2)

PARAMETER	SYMBOL	CONDITIONS	MIN	TYP	MAX	UNITS
CLK Clock Period	$t_{CP}$		40			ns
CLK Pulse-Width High	$t_{CH}$		19			ns
CLK Pulse-Width Low	$t_{CL}$		19			ns
DIN Setup Time	$t_{DS}$		4			ns
DIN Hold Time	$t_{DH}$		8			ns
DOUT Propagation Delay	$t_{DO}$		12		32	ns
DOUT Rise and Fall Time	$t_{DR}, t_{DF}$	$C_{DOUT} = 10pF, 20\%$ to $80\%$			10	ns
LE Pulse-Width High	$t_{LW}$		20			ns
LE Setup Time	$t_{LS}$		15			ns
LE Rising to OUT_ Rising Delay	$t_{LRR}$	(Note 3)			100	ns
LE Rising to OUT_ Falling Delay	$t_{LRF}$	(Note 3)			280	ns
CLK Rising to OUT_ Rising Delay	$t_{CRR}$	(Note 3)			100	ns
CLK Rising to OUT_ Falling Delay	$t_{CRF}$	(Note 3)			310	ns
$\overline{OE}$ Rising to OUT_ Rising Delay	$t_{\overline{OE}H}$	(Note 3)			100	ns
$\overline{OE}$ Falling to OUT_ Falling Delay	$t_{\overline{OE}L}$	(Note 3)			300	ns
LED Output OUT_ Turn-On Fall Time	$t_f$	80% to 20% (Note 3)			200	ns
LED Output OUT_ Turn-Off Rise Time	$t_r$	20% to 80% (Note 3)			120	ns

# 8-Port, 36V Constant-Current LED Driver with LED Fault Detection

## 3.3V TIMING CHARACTERISTICS

(Typical Operating Circuit,  $V_+ = 3V$  to  $5.5V$ ,  $T_A = T_{MIN}$  to  $T_{MAX}$ , unless otherwise noted.) (Notes 1, 2)

PARAMETER	SYMBOL	CONDITIONS	MIN	TYP	MAX	UNITS
CLK Clock Period	$t_{CP}$		52			ns
CLK Pulse-Width High	$t_{CH}$		24			ns
CLK Pulse-Width Low	$t_{CL}$		24			ns
DIN Setup Time	$t_{DS}$		4			ns
DIN Hold Time	$t_{DH}$		8			ns
DOUT Propagation Delay	$t_{DO}$		12		48	ns
DOUT Rise and Fall Time	$t_{DR}, t_{DF}$	$C_{DOUT} = 10pF$			12	ns
LE Pulse-Width High	$t_{LW}$		20			ns
LE Setup Time	$t_{LS}$		15			ns
LE Rising to OUT_ Rising Delay	$t_{LRR}$	(Note 3)			140	ns
LE Rising to OUT_ Falling Delay	$t_{LRF}$	(Note 3)			310	ns
CLK Rising to OUT_ Rising Delay	$t_{CRR}$	(Note 3)			140	ns
CLK Rising to OUT_ Falling Delay	$t_{CRF}$	(Note 3)			340	ns
$\overline{OE}$ Rising to OUT_ Rising Delay	$t_{\overline{OE}H}$	(Note 3)			140	ns
$\overline{OE}$ Falling to OUT_ Falling Delay	$t_{\overline{OE}L}$	(Note 3)			330	ns
LED Output OUT_ Turn-On Fall Time	$t_f$	80% to 20%; pullup resistor = $65\Omega$ (Note 3)			250	ns
LED Output OUT_ Turn-Off Rise Time	$t_r$	20% to 80%; pullup resistor = $65\Omega$ (Note 3)			150	ns

**Note 1:** All parameters are tested at  $T_A = +25^\circ C$ . Specifications over temperature are guaranteed by design.

**Note 2:** See Figure 3.

**Note 3:** A  $65\Omega$  pullup resistor is connected from OUT\_ to 5.5V.

## Typical Operating Characteristics

( $T_A = +25^\circ C$ , unless otherwise noted.)

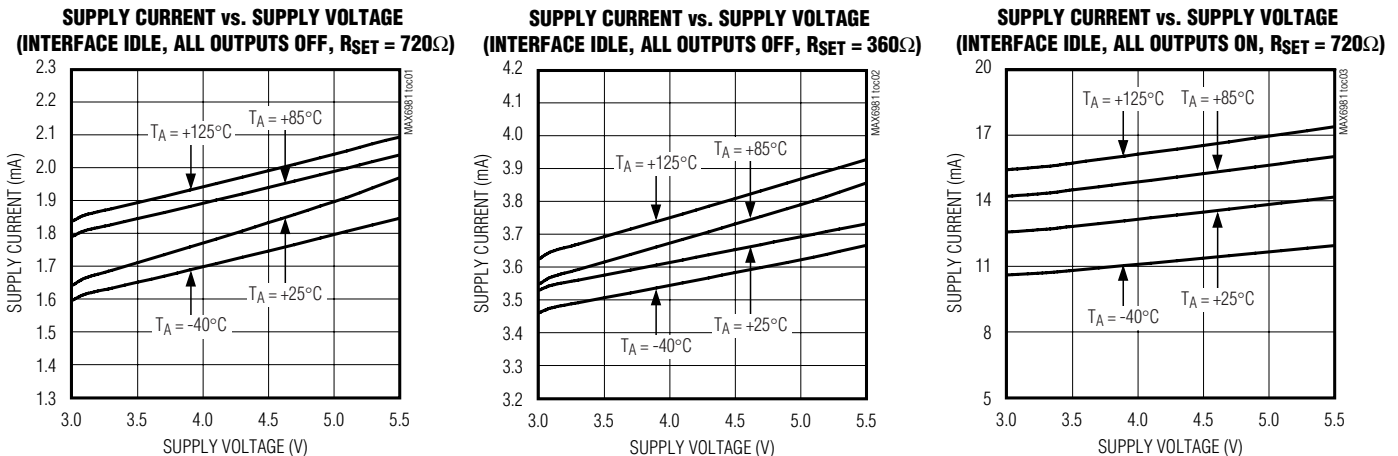

# 8-Port, 36V Constant-Current LED Driver with LED Fault Detection

MAX6981

## Typical Operating Characteristics (continued)

( $T_A = +25^\circ\text{C}$ , unless otherwise noted.)

**SUPPLY CURRENT vs. SUPPLY VOLTAGE**  
(INTERFACE IDLE, ALL OUTPUTS ON,  $R_{SET} = 360\Omega$ )

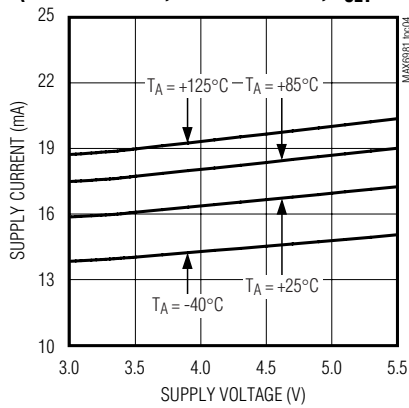

**PORT OUTPUT CURRENT vs. PORT OUTPUT VOLTAGE** ( $R_{SET} = 720\Omega$ ,  $V_+ = 3.3V$ )

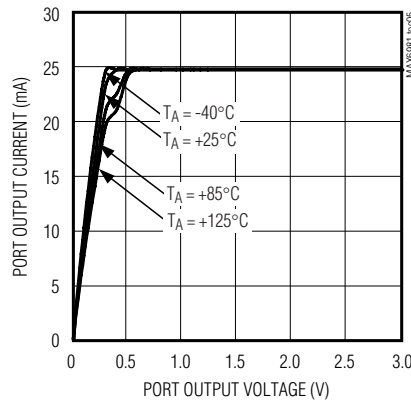

**PORT OUTPUT CURRENT vs. PORT OUTPUT VOLTAGE** ( $R_{SET} = 360\Omega$ ,  $V_+ = 3.3V$ )

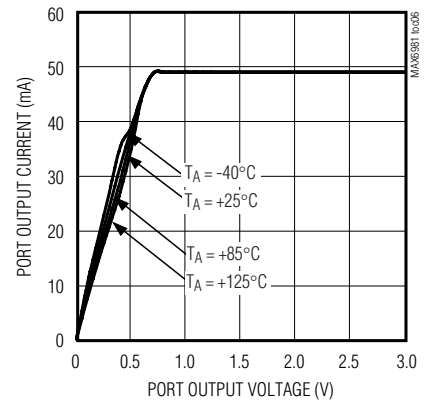

**PORT OUTPUT CURRENT vs. PORT OUTPUT VOLTAGE** ( $R_{SET} = 720\Omega$ ,  $V_+ = 5.0V$ )

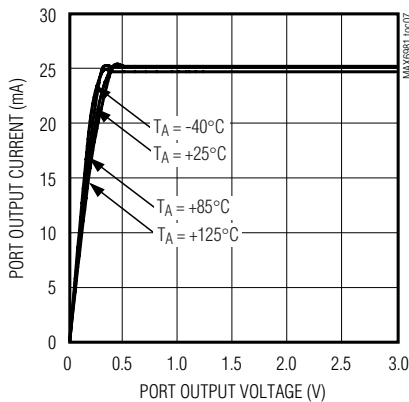

**PORT OUTPUT CURRENT vs. PORT OUTPUT VOLTAGE** ( $R_{SET} = 360\Omega$ ,  $V_+ = 5.0V$ )

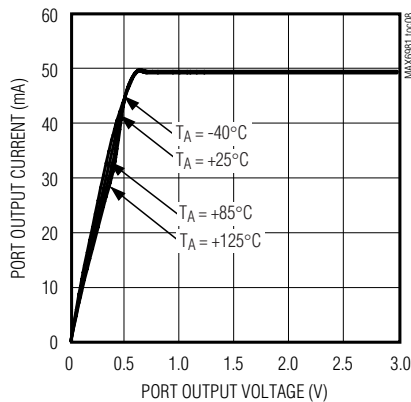

**PORT OUTPUT CURRENT vs. SUPPLY VOLTAGE**  
( $R_{SET} = 720\Omega$ ,  $V_{OUT} = 2V$ )

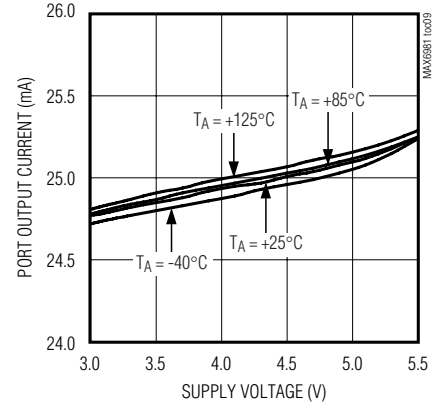

**PORT OUTPUT CURRENT vs. SUPPLY VOLTAGE**  
( $R_{SET} = 360\Omega$ ,  $V_{OUT} = 2V$ )

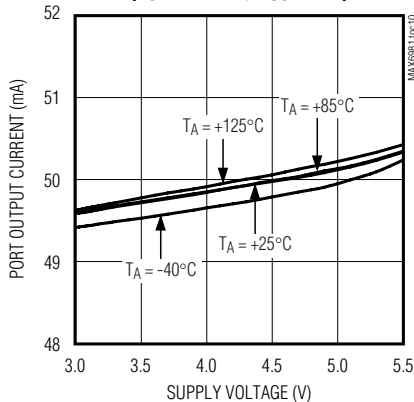

**PORT OUTPUT CURRENT vs.  $R_{SET}$  RESISTANCE** ( $V_+ = 5.0V$ )

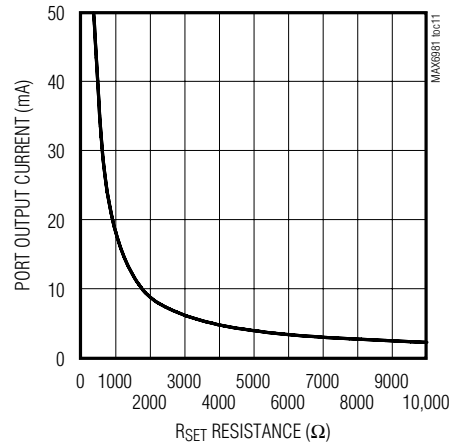

# 8-Port, 36V Constant-Current LED Driver with LED Fault Detection

## Pin Description

PIN	NAME	FUNCTION
1	GND	Ground
2	DIN	Serial-Data Input. Data is loaded into the internal 8-bit shift register on CLK's rising edge.
3	CLK	Serial-Clock Input. Data is loaded into the internal 8-bit shift register on CLK's rising edge.
4	LE	Load-Enable Input. Data is loaded transparently from the internal shift register to the output latch while LE is high. Data is latched into the output latch on LE's falling edge, and retained while LE is low.
5–12	OUT0–OUT7	LED Driver Outputs. OUT0 to OUT7 are open-drain, constant-current-sinking outputs rated to 36V.
13	$\overline{\text{OE}}$	Output-Enable Input. High forces outputs OUT0 to OUT7 high impedance, without altering the contents of the output latches. Low enables outputs OUT0 to OUT7 to follow the state of the output latches.
14	DOUT	Serial-Data Output. Data is clocked out of the 8-bit internal shift-register to DOUT on CLK's rising edge.
15	SET	LED Current Setting. Connect SET to GND through a resistor ( $R_{\text{SET}}$ ) to set the maximum LED current.
16	V+	Positive Supply Voltage. Bypass V+ to GND with a 0.1 $\mu\text{F}$ ceramic capacitor.
EP (TSSOP)	—	Exposed Pad. Although not required, connecting EP to ground improves thermal performance.

## Detailed Description

The MAX6981 LED driver comprises a 4-wire serial interface driving eight constant-current-sinking, open-drain output ports. The outputs drive LEDs in either static or multiplex applications (Figure 1). The constant-current outputs are guaranteed for current accuracy, not only with chip-supply voltage variations (5V  $\pm$ 10% and 3V to 5.5V), but also over a realistic range of driver output voltage drop (0.8V to 2.5V). The drivers use current-sensing feedback circuitry (not simple current mirrors) to ensure very small-current variations over the full allowed range of output voltage (see the *Typical Operating Characteristics*).

The 4-wire serial interface comprises an 8-bit shift register and an 8-bit transparent latch. The shift register is written through a clock input, CLK, and a data input, DIN, and the data propagates to a data output, DOUT. The data output allows multiple drivers to be cascaded and operated together. The contents of the 8-bit shift register are loaded into the transparent latch through a latch-enable input, LE. The latch is transparent to the shift register outputs when high, and latches the current state on the falling edge of LE.

Each driver output is an open-drain, constant-current sink, which should be connected to the cathode of either a single LED or a series string of multiple LEDs. The LED anode can be connected to a supply voltage of up to 36V, independent of the MAX6981 supply, V+. The constant-current capability is up to 55mA per output, set for all eight outputs by an external resistor,  $R_{\text{SET}}$ .

## 4-Wire Serial Interface

The serial interface on the MAX6981 is a 4-wire serial interface, using four inputs (DIN, CLK, LE,  $\overline{\text{OE}}$ ) and a data output (DOUT). This interface is used to write display data to the MAX6981. The serial-interface data word length is 8 bits, D0–D7. See Figures 2 and 3.

The functions of the five interface pins are as follows. DIN is the serial-data input, and must be stable when it is sampled on the rising edge of CLK. Data is shifted in, MSB first. This means that data bit D7 is clocked in first, followed by 7 more data bits, finishing with the LSB D0.

CLK is the serial-clock input, which shifts data at DIN into the MAX6981's 8-bit shift register on its rising edge.

LE is the load input latch that transfers data from the MAX6981 8-bit shift register to its 8-bit latch when LE is high (transparent latch), and latches the data on the falling edge of LE (Figure 2).

The fourth input provides output-enable control of the output drivers.  $\overline{\text{OE}}$  is high to force outputs OUT0 to OUT7 high impedance, without altering the contents of the output latches, and low to enable outputs OUT0 to OUT7 to follow the state of the output latches.

$\overline{\text{OE}}$  is independent of the serial-interface operation. Data can be shifted into the serial-interface shift register and latched regardless of the state of  $\overline{\text{OE}}$ .

DOUT is the serial-data output, which shifts data out from the MAX6981's 8-bit shift register on the rising edge of CLK. Data at DIN is propagated through the shift register and appears at DOUT eight clock cycles later. See Figure 2.

# 8-Port, 36V Constant-Current LED Driver with LED Fault Detection

MAX6981

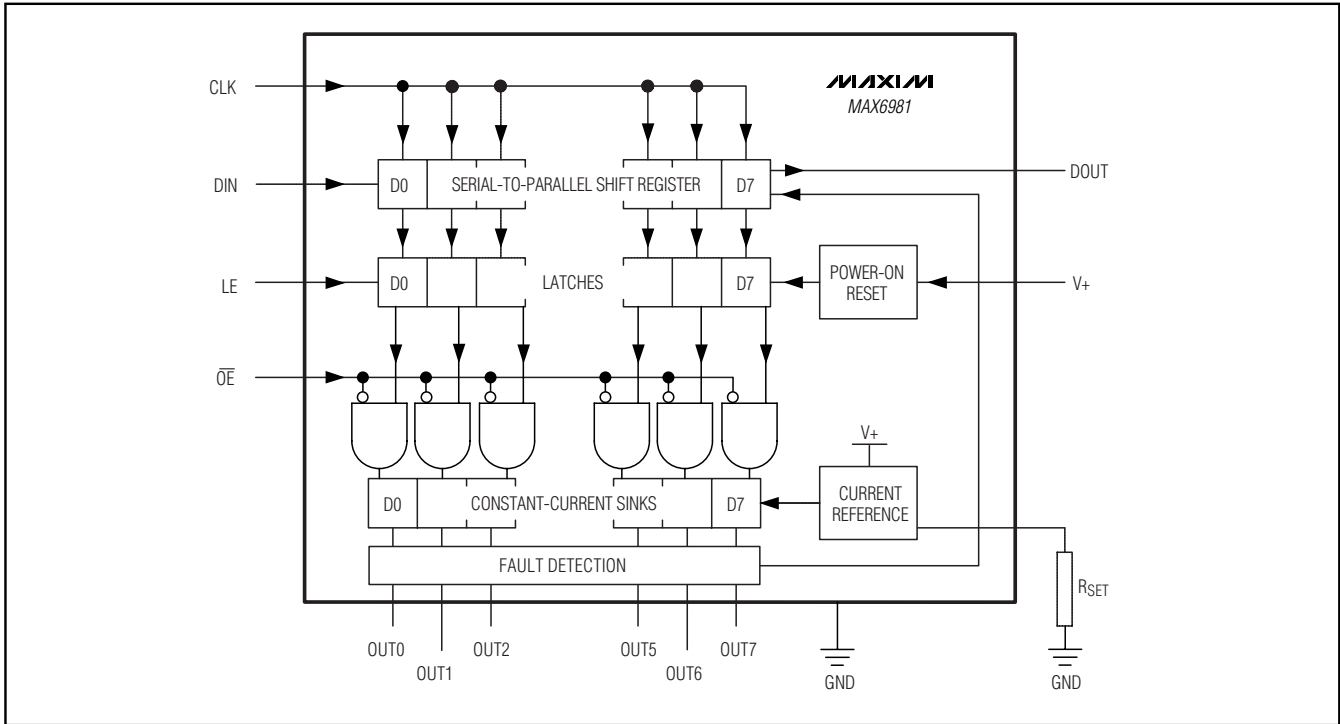

Figure 1. Block Diagram

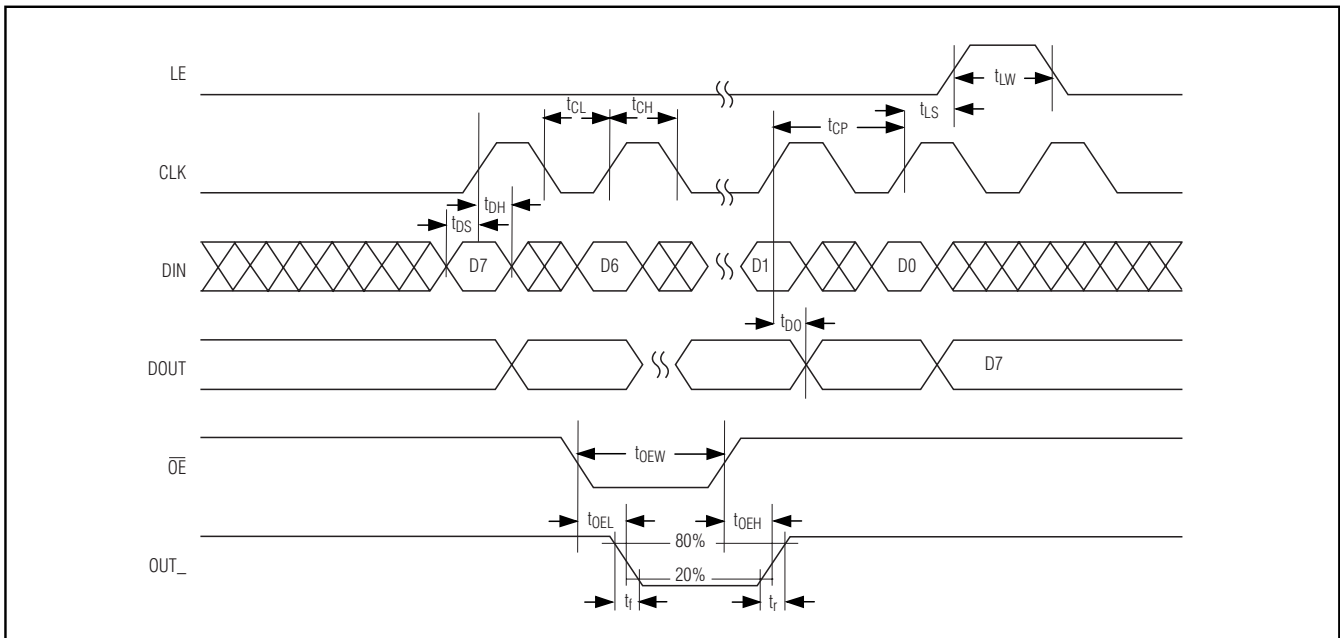

Figure 2. 4-Wire Serial-Interface Timing Diagram

# 8-Port, 36V Constant-Current LED Driver with LED Fault Detection

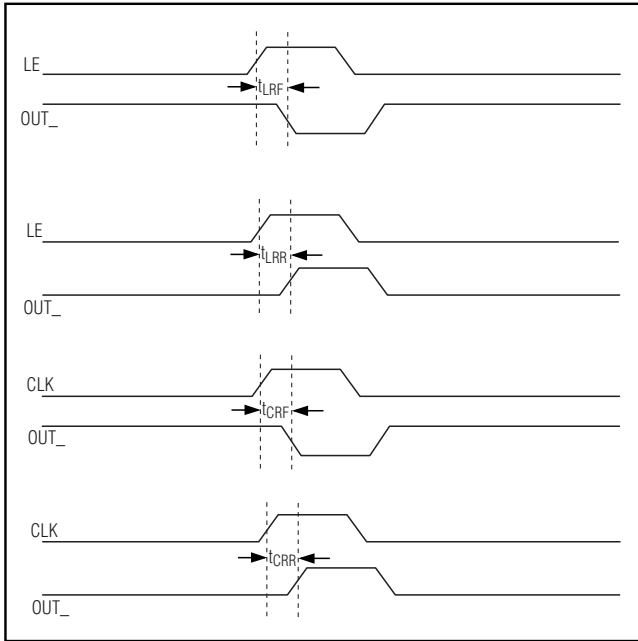

Figure 3. LE and CLK to OUT\_ Timing

## LED Fault Detection

The MAX6981 includes circuitry that detects open-circuit LEDs automatically. An open-circuit fault occurs when an output is programmed to sink current but no current flows. Open circuits are checked just after the falling edge of  $\overline{OE}$ . If one or more output ports are detected with an open-circuit fault, the D6 and D5 bits of DOUT go high. If no open-circuit faults are detected, D6 and D5 are set to low. The data in the other 6-bit positions in DOUT are not altered.

Fault status is shifted out on DOUT when the next data transmission is shifted in after the rising edge of LE. LE is normally taken high after all 8 bits of new LED data have been clocked into the shift register(s), and then DOUT outputs data bit D7. On the next two rising edges of CLK, the 2 fault-status bits, D6 and D5, are clocked out in that order, followed by the remaining 5 unchanged data bits D4 to D0.

A typical fault-detecting application tests all the shifted out data. Bits D0–D4 and D7 are checked against the originally transmitted data to check data-link integrity. Bits D5 and D6 are checked first to see that they contain the same data (validating the status) and second, whether faults are reported or not by the actual logic level.

Figure 4 is the LE,  $\overline{OE}$ , and CLK to DOUT timing diagram.

## Applications Information

### Selecting External Component R<sub>SET</sub> to Set LED Output Current

The MAX6981 uses an external resistor R<sub>SET</sub> to set the LED current for outputs OUT0 to OUT7. The minimum allowed value of R<sub>SET</sub> is 327.3Ω, which sets the output currents up to 55mA. The reference value, 360Ω, sets the output currents to 50mA. To set a different output current, use the formula:

$$R_{SET} = 18,000 / I_{OUT}$$

where I<sub>OUT</sub> is the desired output current in mA.

### Computing Power Dissipation

The upper limit for power dissipation (P<sub>D</sub>) for the MAX6981 is determined from the following equation:

$$P_D = (V_+ \times I_+) + (V_{OUT} \times DUTY \times I_{OUT} \times N)$$

where:

V<sub>+</sub> = supply voltage

I<sub>+</sub> = operating supply current when sinking I<sub>OUT</sub> LED drive current into N outputs

DUTY = PWM duty cycle applied to  $\overline{OE}$

N = number of MAX6981 outputs driving LEDs at the same time (maximum is eight)

V<sub>OUT</sub> = MAX6981 port output voltage when driving load LED(s)

I<sub>OUT</sub> = LED drive current programmed by R<sub>SET</sub>

P<sub>D</sub> = power dissipation, in mW if currents are in mA.

Dissipation example:

I<sub>OUT</sub> = 50mA, N = 8, DUTY = 1, V<sub>OUT</sub> = 2V, V<sub>+</sub> = 5.25V

$$P_D = (5.25V \times 25mA) + (2V \times 1 \times 50mA \times 8) = 0.931W.$$

Thus, for a 16-pin TSSOP package ( $T_{JA} = 1 / 0.0213 = +46.95^\circ\text{C/W}$  from the *Absolute Maximum Ratings*), the maximum allowed ambient temperature T<sub>A</sub> is given by:

$$T_{J(MAX)} = T_A + (P_D \times T_{JA}) = +150^\circ\text{C} = T_A + (0.931 \times 46.95^\circ\text{C/W})$$

so T<sub>A</sub> = +106.3°C.

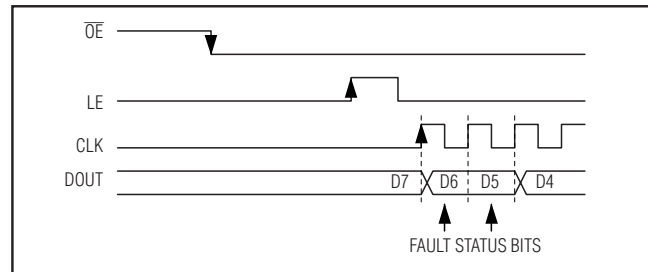

Figure 4. Fault Timing





# 8-Port, 36V Constant-Current LED Driver with LED Fault Detection

## Selector Guide

PART	NUMBER OF OUTPUTS	MAX OUTPUT VOLTAGE (V)	MAX OUTPUT CURRENT	LED FAULT DETECTION	WATCHDOG
MAX6968	8	5.5	55mA	—	—
MAX6977				Yes	—
MAX6978				Yes	Yes
MAX6970	8	36		—	—
MAX6981				Yes	—
MAX6980				Yes	Yes
MAX6969	16	5.5		—	—
MAX6979				Yes	Yes
MAX6971			—	—	
MAX6983	16	36	Yes	Yes	

## Typical Application Circuit

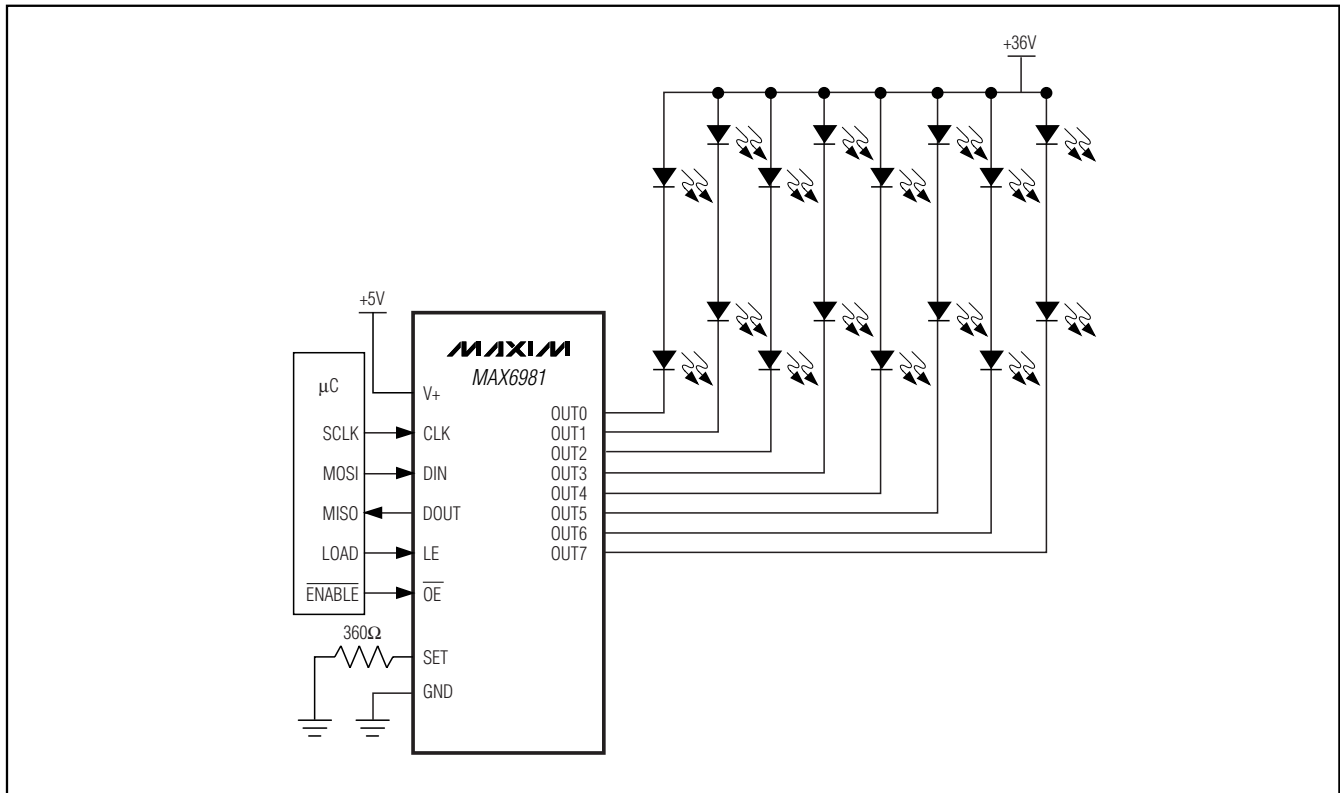

# 8-Port, 36V Constant-Current LED Driver with LED Fault Detection

## Package Information

(The package drawing(s) in this data sheet may not reflect the most current specifications. For the latest package outline information, go to [www.maxim-ic.com/packages](http://www.maxim-ic.com/packages).)

MAX6981

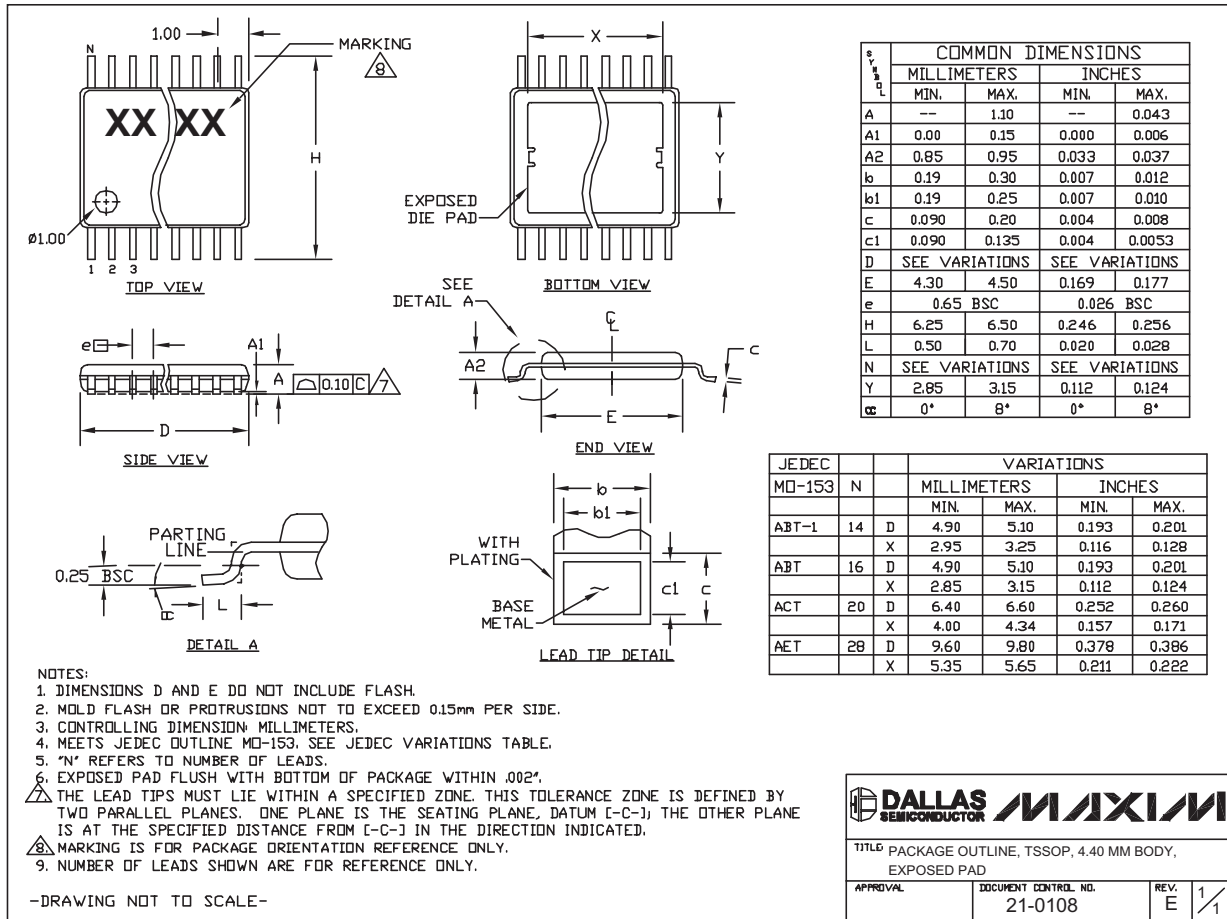

TSSOP 4.4mm BODY/EP

# 8-Port, 36V Constant-Current LED Driver with LED Fault Detection

## Package Information (continued)

(The package drawing(s) in this data sheet may not reflect the most current specifications. For the latest package outline information, go to [www.maxim-ic.com/packages](http://www.maxim-ic.com/packages).)

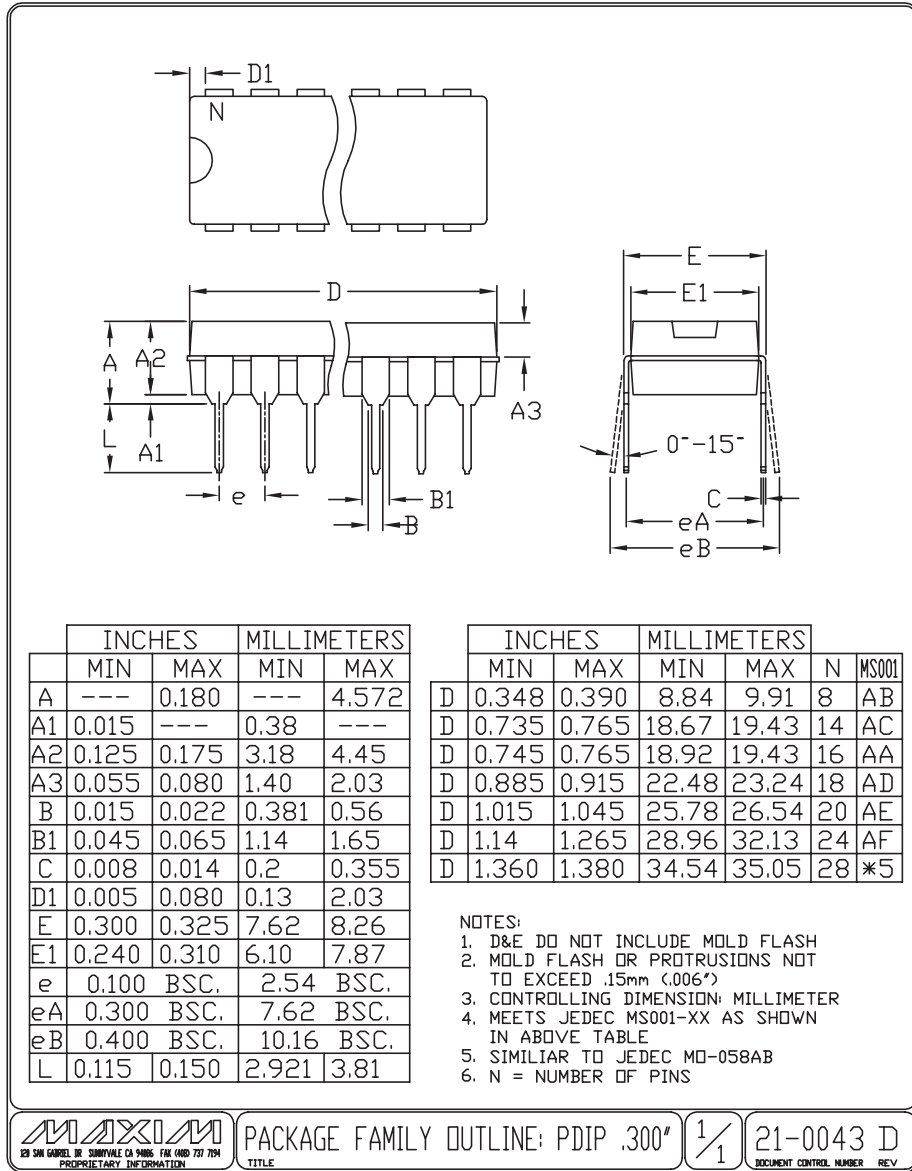

PACKAGE FAMILY OUTLINE: PDIP .300" 1/1

21-0043 D DOCUMENT CONTROL NUMBER REV

# 8-Port, 36V Constant-Current LED Driver with LED Fault Detection

## Package Information (continued)

(The package drawing(s) in this data sheet may not reflect the most current specifications. For the latest package outline information, go to [www.maxim-ic.com/packages](http://www.maxim-ic.com/packages).)

MAX6981

SSOP:EPS

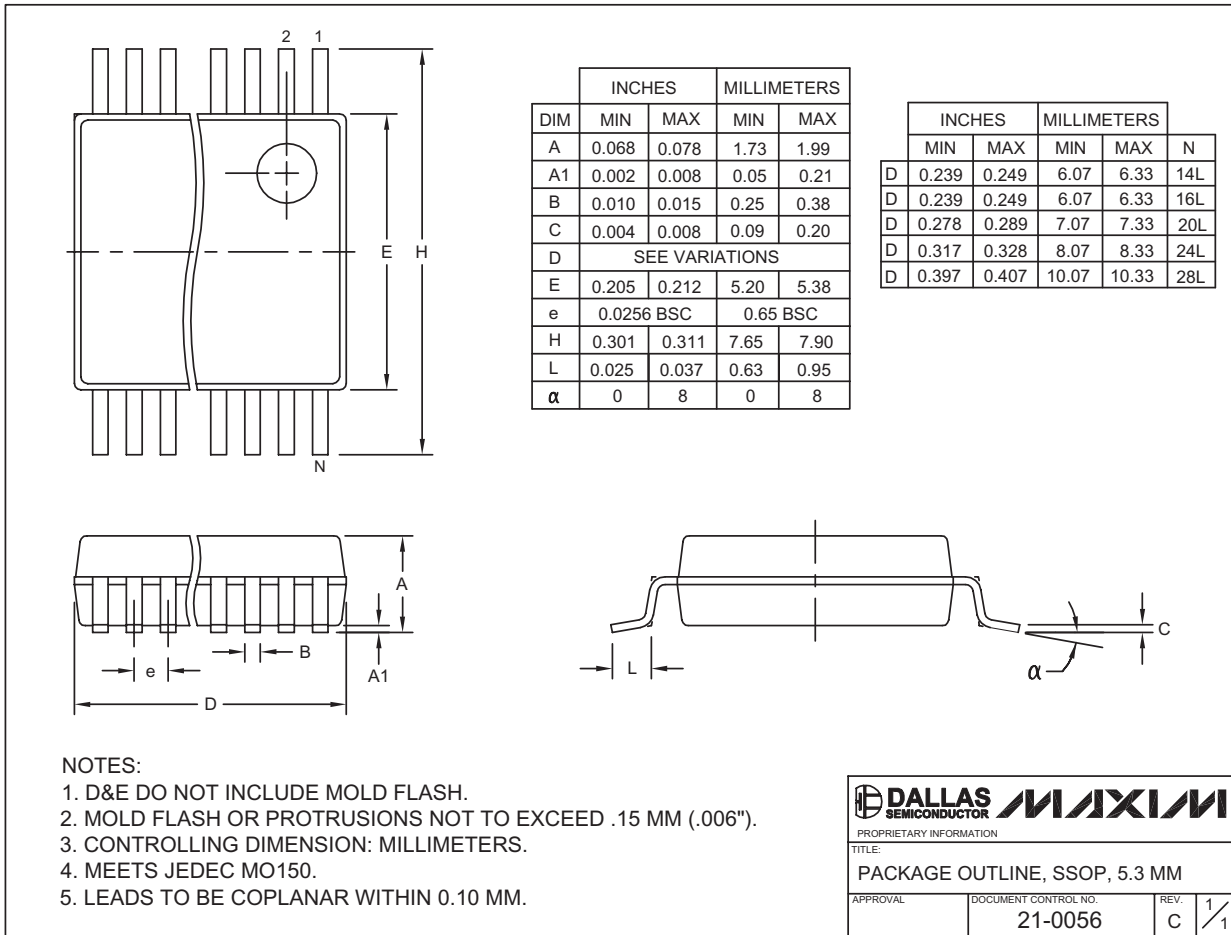

Maxim cannot assume responsibility for use of any circuitry other than circuitry entirely embodied in a Maxim product. No circuit patent licenses are implied. Maxim reserves the right to change the circuitry and specifications without notice at any time.

Maxim Integrated Products, 120 San Gabriel Drive, Sunnyvale, CA 94086 408-737-7600 13