

DESCRIPTION

Demonstration circuit 801 is a general purpose positive to negative converter featuring the LT[®]3483ES6. The demo board demonstrates two separate DC/DC converters. One converter generates a -8V at 20mA to 30mA from a 2.7V-4.2V input using a step up inverting charge pump topology. The other uses a dual coupled inductor in an inverting flyback topology to generate a -15V at 8mA to 40mA from a 2.7-12V input. This topology is useful to generate output voltages of lower, equal or higher magnitude than the input. For example, for a -12V supply just change the

value of R2 to 1.21M and for a -5V, change R2 to 511K. Both circuits demonstrate low component count and are intended for space-conscious applications such as LCD bias, Handheld Computers, Battery Backup, Digital Cameras and OLED Bias.

Design files for this circuit board are available. Call the LTC factory.

LTC is a registered trademark of Linear Technology Corporation

Table 1. Performance Summary (T_A = 25°C)

PARAMETERS FOR -8V INVERTER	CONDITION	VALUE
Minimum Input Voltage		2.7V
Maximum Input Voltage		4.2V
Output Voltage V _{OUT}	V _{IN} = 2.5V to 4.2V, I _{OUT} = 20mA to 30mA	-8V ±3%
Typical efficiency	V _{IN} = 3.3V, I _{OUT} = 25mA	67%
Typical Output Ripple	V _{IN} = 3.3V, I _{OUT} = 25mA	60mV _{P-P}
PARAMETERS FOR -15V INVERTER		VALUE
Minimum Input Voltage		2.7V
Maximum Input Voltage		12V
Output Voltage V _{OUT}	V _{IN} = 2.7V to 12V, I _{OUT} = 8mA to 40mA	-15V ±3%
Typical efficiency	V _{IN} = 6V, I _{OUT} = 20mA	75%
Typical Output Ripple V _{OUT}	V _{IN} = 6V, I _{OUT} = 20mA	80mV _{P-P}

QUICK START PROCEDURE

Demonstration circuit 801 is easy to set up to evaluate the performance of the LT3483ES6. Refer to Figure 1 for proper measurement equipment setup and follow the procedure below:

NOTE: When measuring the input or output voltage ripple, care must be taken to avoid a long ground lead

on the oscilloscope probe. Measure the input or output voltage ripple by touching the probe tip directly across the V_{in} or V_{out} and GND terminals. See Figure 2 for proper scope probe technique.

1. Place jumper in the following positions for testing of -15V inverter:

QUICK START GUIDE FOR DEMONSTRATION CIRCUIT 801

INVERTING DC/DC CONVERTER

JP1 On

2. With power off, connect the input power supply to Vin and GND.
3. Turn on the power at the input.
4. Check for the proper output voltages.

NOTE: If there is no output, temporarily disconnect the load to make sure that the load is not set too high.

5. Once the proper output voltages are established, adjust the loads within the operating range and observe the output voltage regulation, ripple voltage, efficiency and other parameters.
6. For testing of -8V Inverter repeat steps 1-5 placing **JP2** in the **ON** position.

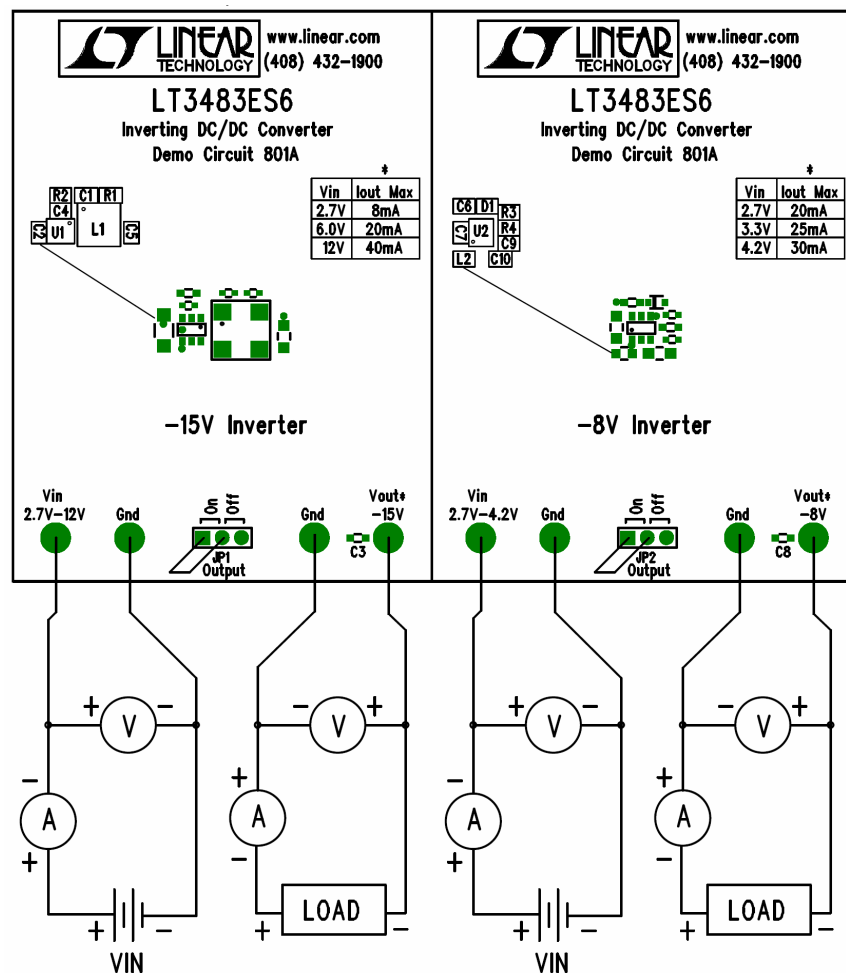

Figure 1. Proper Measurement Equipment Setup

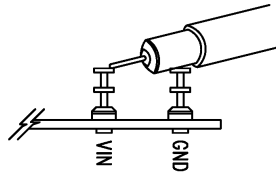
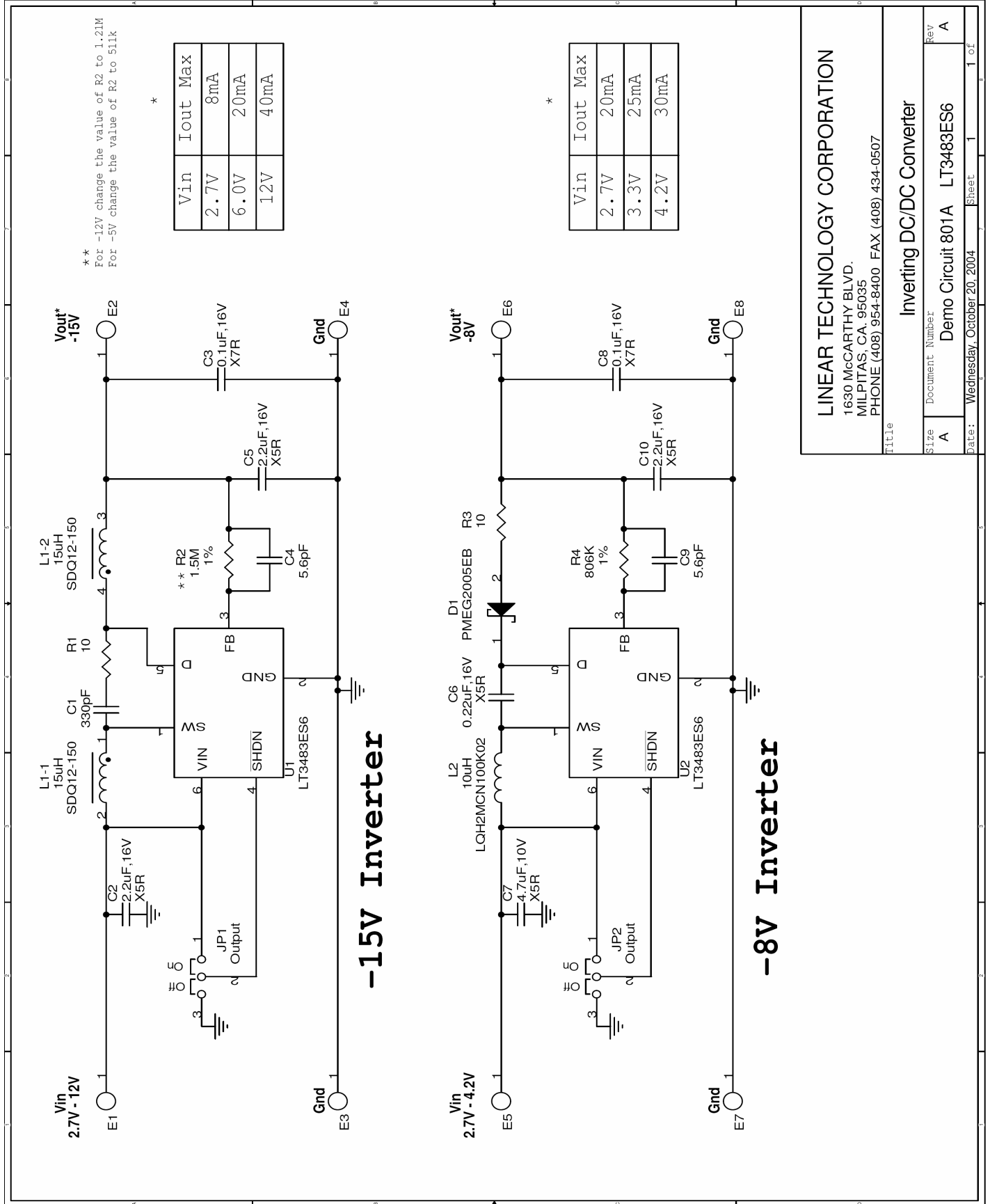

Figure 2. Measuring Input or Output Ripple

QUICK START GUIDE FOR DEMONSTRATION CIRCUIT 801 INVERTING DC/DC CONVERTER



** For -12V change the value of R2 to 1.21M
For -5V change the value of R2 to 511k

*

Win	Iout Max
2.7V	8mA
6.0V	20mA
12V	40mA

*

Win	Iout Max
2.7V	20mA
3.3V	25mA
4.2V	30mA

LINEAR TECHNOLOGY CORPORATION
 1630 MCCARTHY BLVD.
 MILPITAS, CA. 95035
 PHONE (408) 954-8400 FAX (408) 434-0507

Title		Inverting DC/DC Converter	
Size	Document Number	Rev	A
A	Demo Circuit 801A	LT3483ES6	
Date:	Wednesday, October 20, 2004	Sheet	1 of 1