

Part Number: APHB1608CGKSYKC

Green
Super Bright Yellow

Features

- 1.6mmX0.8mm SMT LED, 0.5mm thickness.
- Compatible with reflow soldering.
- Available in various color combination.
- Package: 2000pcs / reel .
- Moisture sensitivity level : level 3.
- Tinned pads for improved solderability.
- RoHS compliant.

Description

The Green source color devices are made with AlGaInP on GaAs substrate Light Emitting Diode.
The Super Bright Yellow device is made with AlGaInP (on GaAs substrate) light emitting diode chip.

Package Dimensions

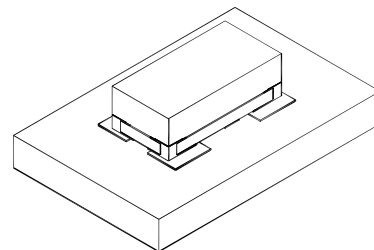
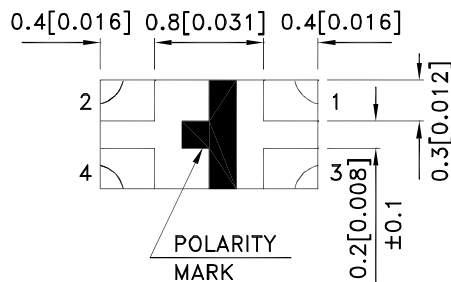
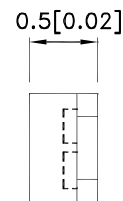
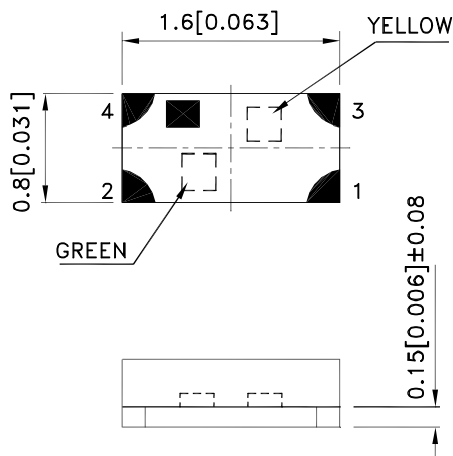

Notes:

1. All dimensions are in millimeters (inches).
2. Tolerance is $\pm 0.15(0.006)$ unless otherwise noted.
3. The specifications, characteristics and technical data described in the datasheet are subject to change without prior notice.
4. The device has a single mounting surface. The device must be mounted according to the specifications.



Selection Guide

Part No.	Dice	Lens Type	Iv (mcd) [2] @ 20mA		Viewing Angle [1]
			Min.	Typ.	2θ1/2
APHB1608CGKSYKC	Green (AlGaInP)	Water Clear	20	50	130°
	Super Bright Yellow (AlGaInP)		80	150	

Notes:

1. θ1/2 is the angle from optical centerline where the luminous intensity is 1/2 of the optical peak value.
2. Luminous intensity/ luminous Flux: +/-15%.
3. Luminous intensity value is traceable to the CIE127-2007 compliant national standards.

Electrical / Optical Characteristics at TA=25°C

Symbol	Parameter	Device	Typ.	Max.	Units	Test Conditions
λ_{peak}	Peak Wavelength	Green Super Bright Yellow	574 590		nm	I _F =20mA
λ_D [1]	Dominant Wavelength	Green Super Bright Yellow	570 590		nm	I _F =20mA
$\Delta\lambda_{1/2}$	Spectral Line Half-width	Green Super Bright Yellow	20 20		nm	I _F =20mA
C	Capacitance	Green Super Bright Yellow	15 20		pF	V _F =0V;f=1MHz
V _F [2]	Forward Voltage	Green Super Bright Yellow	2.1 2	2.5 2.5	V	I _F =20mA
I _R	Reverse Current	Green Super Bright Yellow		10 10	uA	V _R = 5V

Notes:

1. Wavelength: +/-1nm.
2. Forward Voltage: +/-0.1V.
3. Wavelength value is traceable to the CIE127-2007 compliant national standards.

Absolute Maximum Ratings at TA=25°C

Parameter	Green	Super Bright Yellow	Units
Power dissipation	75	75	mW
DC Forward Current	30	30	mA
Peak Forward Current [1]	150	175	mA
Reverse Voltage	5		V
Operating Temperature	-40°C To +85°C		
Storage Temperature	-40°C To +85°C		

Note:

1. 1/10 Duty Cycle, 0.1ms Pulse Width.

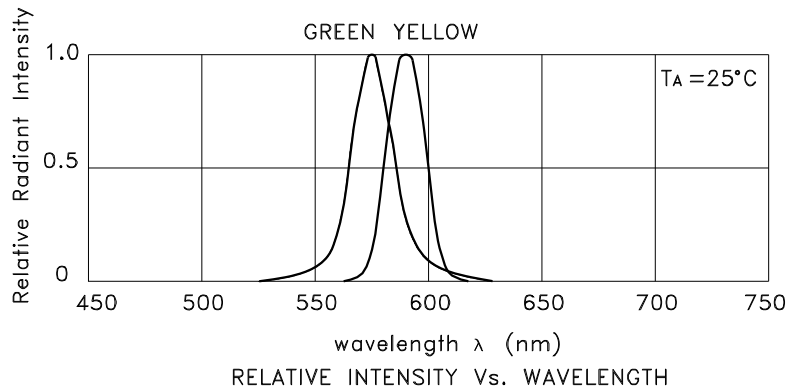

APHB1608CGKSYKC Green

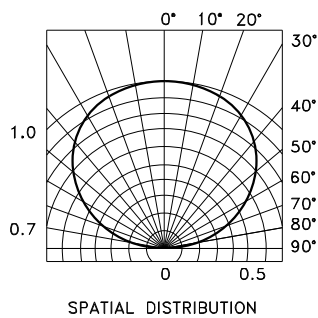
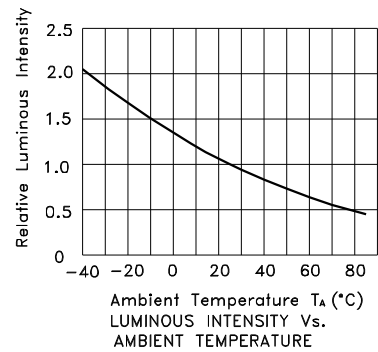
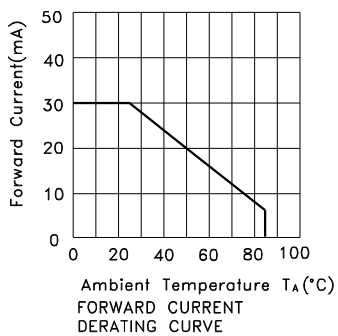
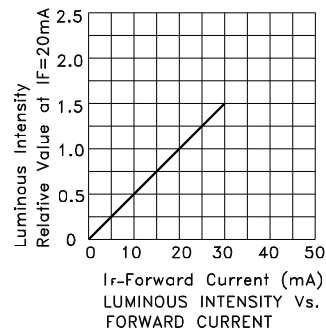
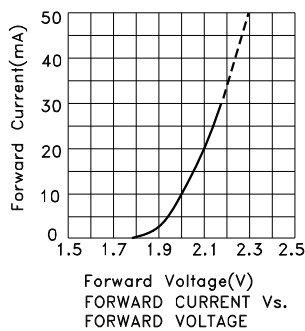

Kingbright

Super Bright Yellow

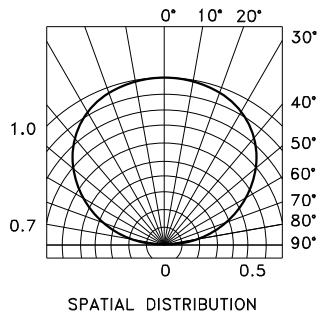
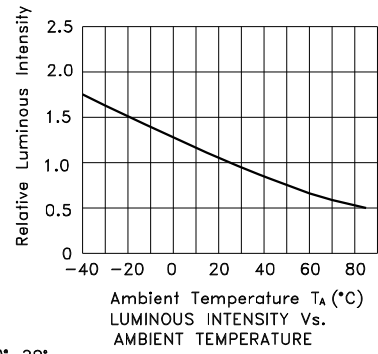
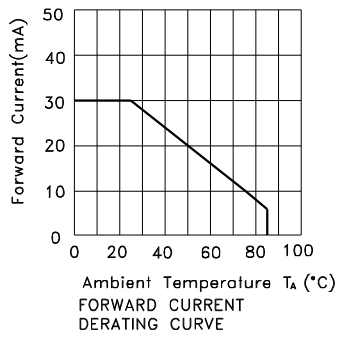
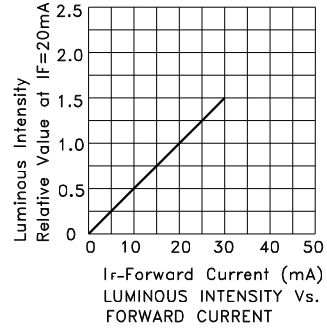
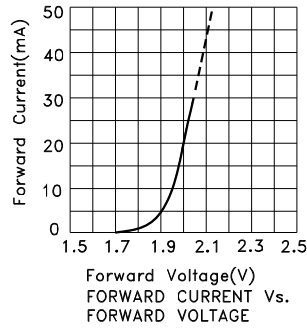

PACKING & LABEL SPECIFICATIONS

APHB1608CGKSYKC

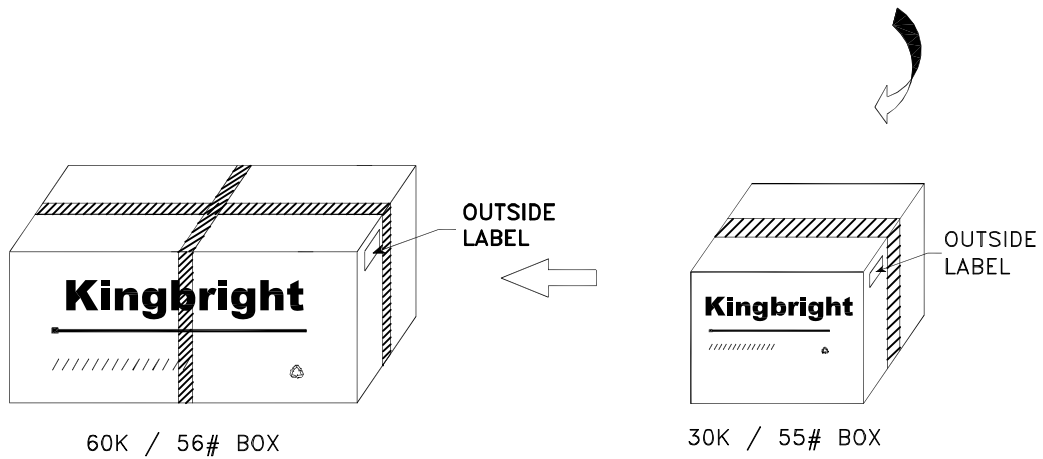
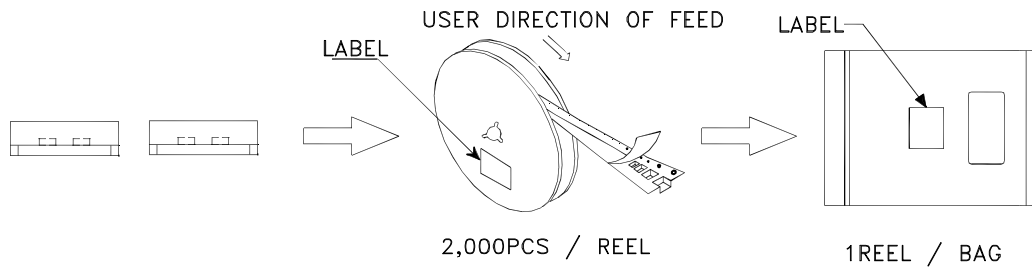

<h1>Kingbright</h1>					
P/NO: APHB1608xxx					
QTY: 2,000 pcs	Q.C.	<table border="1"> <tr> <td>Q C</td> </tr> <tr> <td>XX XX XXXX</td> </tr> <tr> <td>PASSED</td> </tr> </table>	Q C	XX XX XXXX	PASSED
Q C					
XX XX XXXX					
PASSED					
S/N: XXXX					
CODE: XXX					
LOT NO:					
xxxxxxxxxxxxxxxxxxxxxxxx					
RoHS Compliant					

All design applications should refer to Kingbright application notes available at <http://www.KingbrightUSA.com/ApplicationNotes>