

# Enpirion EN5395QI 9A DCDC Converter w/Integrated Inductor Evaluation Board

## Introduction

Thank you for choosing Altera Enpirion power products.

- The EN5395QI features integrated inductor, power MOSFETS, Controller, Compensation Network, and protection circuitry against system faults. This level of integration delivers a substantial reduction in footprint and part count over competing solutions. However, the evaluation board is not optimized for minimum footprint; rather for engineering ease of evaluation through programming options, clip leads, test points etc.
- The EN5395QI features 7 precision preset output voltages selectable via 3 pin VID (Voltage ID) input. The module requires only ceramic input and output capacitors, and a small capacitor for programming soft-start interval.
- The input capacitor is a 10V rated 2X47uF X5R MLCC. The output filter section is populated with 5 x 22uF, 6.3V rated X5R MLC capacitors to achieve the required ~100uF of output capacitance. The combination of 5 x 22uF caps yields very low ESR and hence low output ripple. 2X47uF capacitor may be substituted if minimizing footprint is more important. The Soft-start capacitor is a small 10V rated 15nF X5R MLCC.
- Jumpers are provided for ease of logical 1/0 programming of the following signals:
  - Enable
  - VS0-VS2 output voltage selectEnable may also be controlled using an external switching source by removing the jumper and applying the enable signal to the middle pin and ground.
- The board comes with input decoupling and reverse polarity protection to guard the device against common setup mishaps.

## Quick Start Guide

Figure 1 shows a top view of the evaluation board.

**WARNING:** complete steps 1 through 4 before applying power to the EN5395QI evaluation board.

**STEP 1:** Set the “ENA” jumper to the Disable Position.

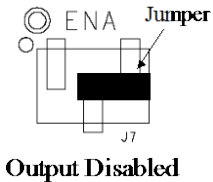

**STEP 2:** Set the VID pins for the desired output voltage - Refer to Table-1.

**CAUTION:** VID pins MUST NOT be changed while the EN5395QI is enabled. Doing so could result in damage to the part.

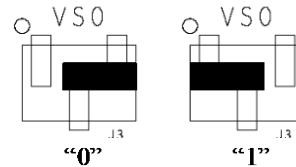

**STEP 3:** Connect Power Supply to the input power connectors, VIN (+) and GND (-) as indicated in Figure 1 and set the power supply to the desired voltage

**CAUTION:** be mindful of the polarity. Even though the evaluation board comes with reverse polarity protection diodes, it is rarely a good idea to reverse the input polarity.

**STEP 4:** Connect the load to the output connectors VOUT (+) and GND (-), as indicated in Figure 1.

**STEP 5:** Power up the board and move the ENA jumper to the enabled position. The EN5395QI is now powered up and generating the desired output.

**STEP 5A: Power Up/Down Behavior** – Remove ENA jumper and connect a pulse generator (output disabled) signal to the middle pin of ENA and Ground. Set the pulse amplitude to go from 0 to 2.5 V. Set the pulse period to 10 msec. and duty cycle to 50%. Hook up oscilloscope probes to ENA, SS and VOUT with clean ground returns. Enable pulse generator output. Observe the SS capacitor and VOUT voltage ramps as ENA goes high and again as ENA goes low.

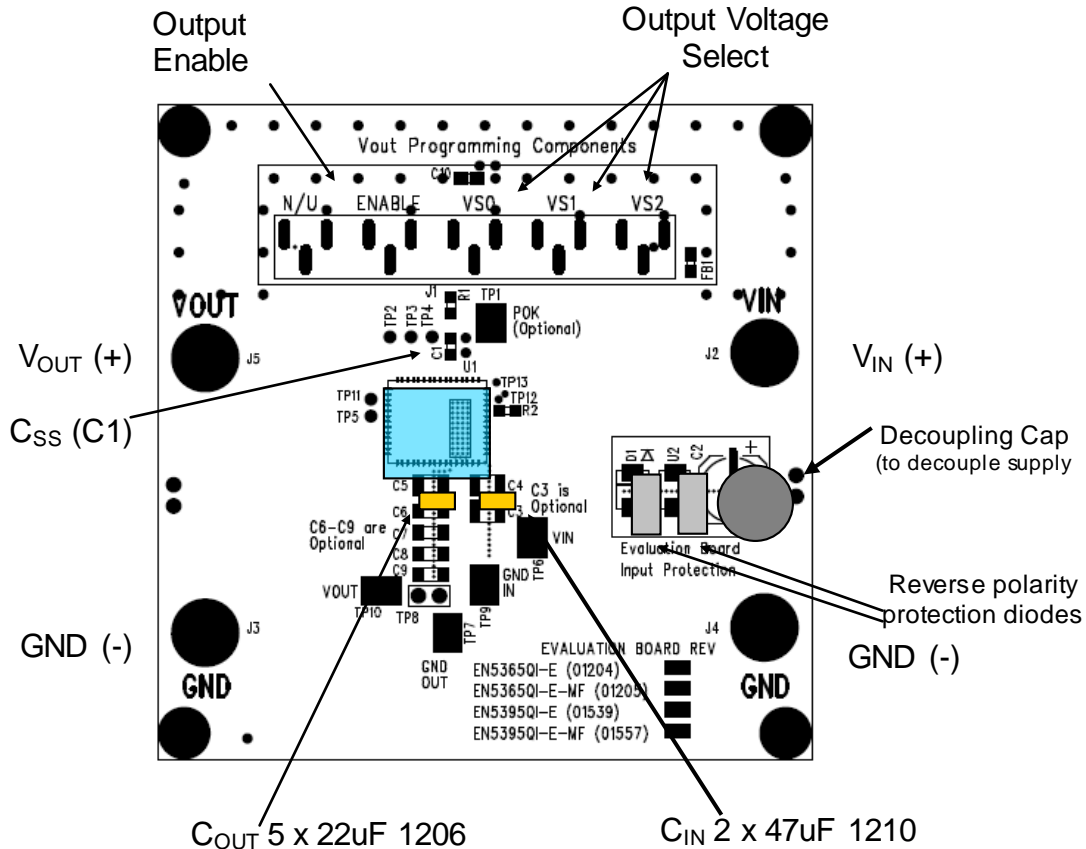

Figure 1. Evaluation Board Layout.

## Output Voltage Select

The EN5395QI utilizes 3 pins to set the output voltage to one of 7 precision preset output voltages. The VID pins, labeled VS[0:2] can be readily set to a logical 0/1 by means of the jumpers provided. A open pin would default to a logical 1 state utilizing the internal pull up. However, tying the pin to a logical 1 by means of a jumper is always recommended.

VS2*	VS1*	VS0*	Output Voltage
0	0	0	3.3V
0	0	1	2.5V
0	1	0	1.8V
0	1	1	1.5V
1	0	0	1.25V
1	0	1	1.2V
1	1	0	0.8V
1	1	1	Reserved

Table 1. Output Voltage Select Truth Table

**WARNING:** Voltage select pins must not be switched while part is enabled. Doing so could result in damage to the part. Always disable part when changing output voltage setting.

## Test Recommendations

To guarantee measurement accuracy, the following precautions should be observed:

1. Make all input and output voltage measurements at the board using the test points provided. This will eliminate voltage drop across the line and load cables that can produce false readings.
2. Measure input and output current with series ammeters or accurate shunt resistors. This is especially important when measuring efficiency.
3. Use a balanced impedance probe tip to measure switching signals to avoid noise coupling into the probe ground lead. Output ripple and load transient deviations are best measured at TP8.
4. The board includes a 5.6k pull-up for the POK signal and ready to monitor the power OK status.
5. A 15nF soft-start capacitor is populated on the board for ~1msec soft-start time.
6. This evaluation board is not set up for paralleling multiple devices for greater load capability. A separate evaluation board is available that demonstrates a method for parallel operation of 2 EN5395QI devices.
7. The over-current protection circuit typically limits the maximum load current to approximately 1.5X the rated value – viz. 9A. However, this is somewhat adjustable via the ROCP pin. Please consult our Applications Engineering group for assistance in using this feature.
8. **DERATING:** The evaluation board may not be operated with maximum power dissipation (input power – output power) beyond a certain temperature (reference current derating curves in figure 2) for extended periods of time. The device will shut down when the internal junction temperature exceeds ~150°C.

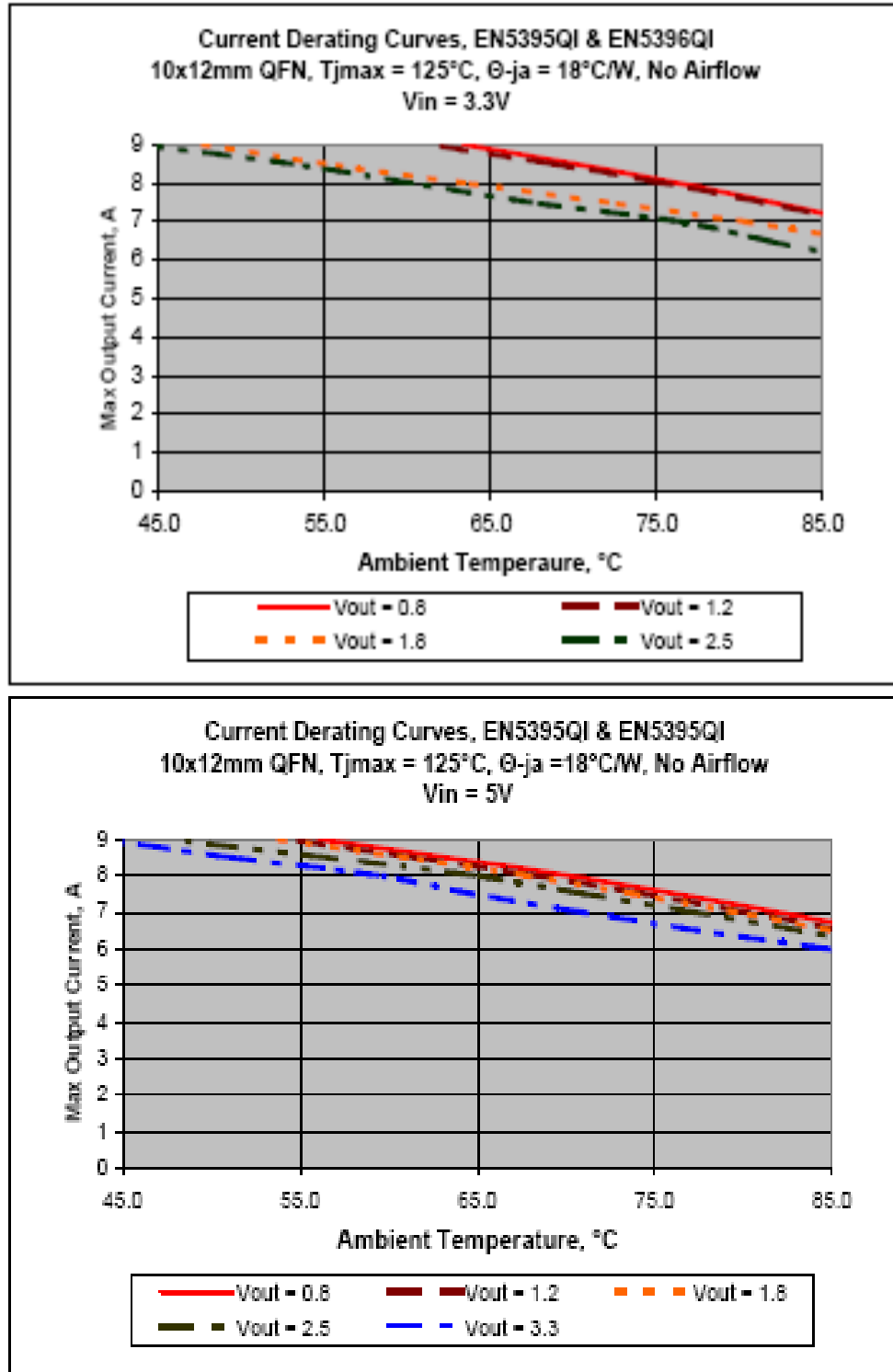

Figure 2. Current Derating Curves

## Input and Output Capacitors

The **input** capacitance requirement is 2X47uF for the EN5395QI. Altera recommends that a low ESR MLCC capacitor be used. The voltage rating should be high enough to provide adequate margin for your application.

The **output** capacitance requirement is 5X22uF of capacitance and comes populated with 5, 22uF 1210 6.3V MLCCs.

**NOTE:** Capacitors must be X5R or X7R dielectric formulations to ensure adequate capacitance over operating voltage and temperature ranges.

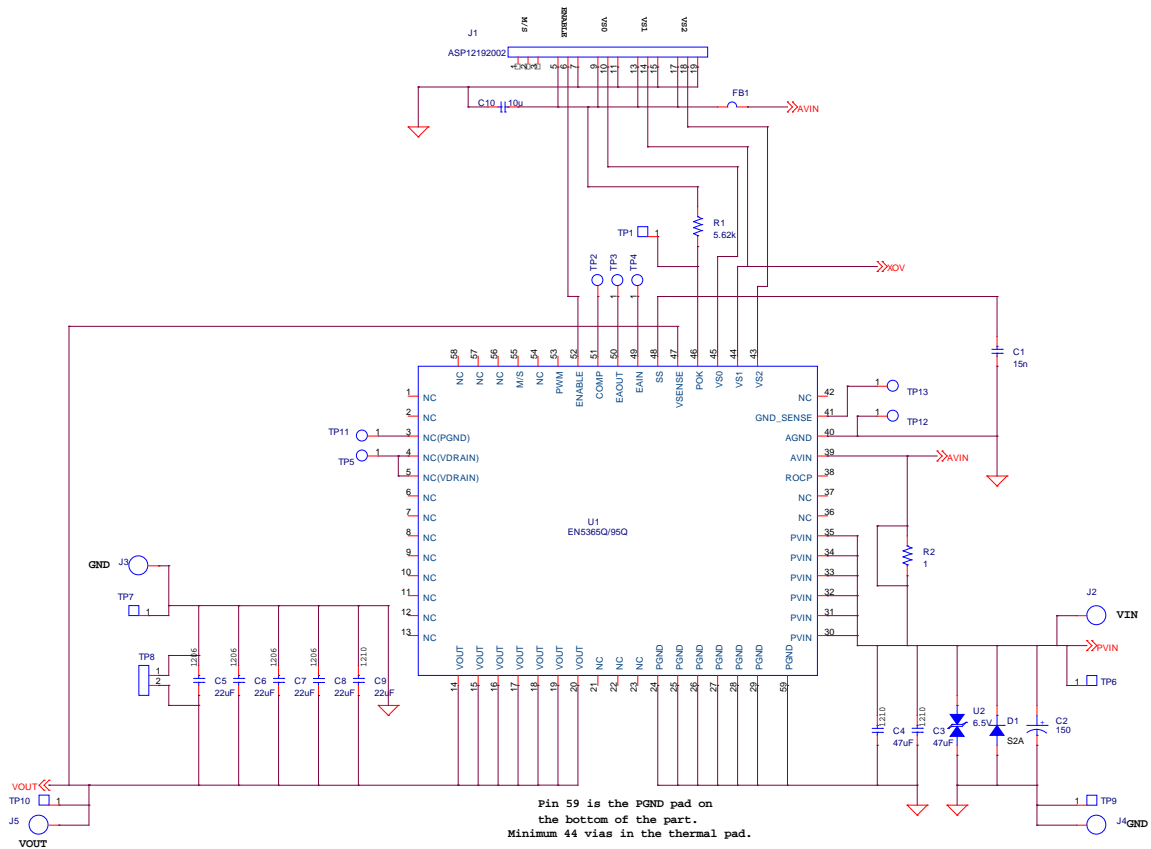

## EN5395QI Evaluation Board Schematic



## Contact Information

Altera Corporation  
101 Innovation Drive  
San Jose, CA 95134  
Phone: 408-544-7000  
<http://www.altera.com>

© 2013 Altera Corporation—Confidential. All rights reserved. ALTERA, ARRIA, CYCLONE, ENPIRION, HARDCOPY, MAX, MEGACORE, NIOS, QUARTUS and STRATIX words and logos are trademarks of Altera Corporation and registered in the U.S. Patent and Trademark Office and in other countries. All other words and logos identified as trademarks or service marks are the property of their respective holders as described at [www.altera.com/common/legal.html](http://www.altera.com/common/legal.html). Altera warrants performance of its semiconductor products to current specifications in accordance with Altera's standard warranty, but reserves the right to make changes to any products and services at any time without notice. Altera assumes no responsibility or liability arising out of the application or use of any information, product, or service described herein except as expressly agreed to in writing by Altera. Altera customers are advised to obtain the latest version of device specifications before relying on any published information and before placing orders for products or services.