



# QUICKSWITCH® PRODUCTS HIGH-SPEED CMOS QUADRUPLE BUS SWITCH WITH INDIVIDUAL ACTIVE LOW ENABLES

IDTQS3125

## FEATURES:

- Enhanced N channel FET with no inherent diode to Vcc
- Pin compatible with the 74'125 function
- Zero propagation delay, zero added ground bounce
- Undershoot clamp diodes on all switch and control inputs
- Available in QSOP and SOIC packages

## APPLICATIONS:

- Hot-swapping, hot-docking
- Voltage translation (5V to 3.3V)
- Power conservation
- Capacitance reduction and isolation (mass storage, work stations)
- Logic replacement (data processing)
- Clock gating
- Bus isolation

## DESCRIPTION:

The QS3125 provides a set of four high-speed low resistance CMOS switches connecting inputs to outputs without propagation delay and without generating additional ground bounce noise. Individual enables ( $\overline{OE}$ ) are used to turn on the switches. The QS3125 is ideal for signal and control switching since the device adds no noise, ground bounce, propagation delay, or significant power consumption to the system. The QS3125 can also be used for analog switching applications such as video.

QuickSwitch devices provide an order of magnitude faster speed than conventional logic devices.

The QS3125 is characterized for operation at  $-40^{\circ}\text{C}$  to  $+85^{\circ}\text{C}$ .

## FUNCTIONAL BLOCK DIAGRAM

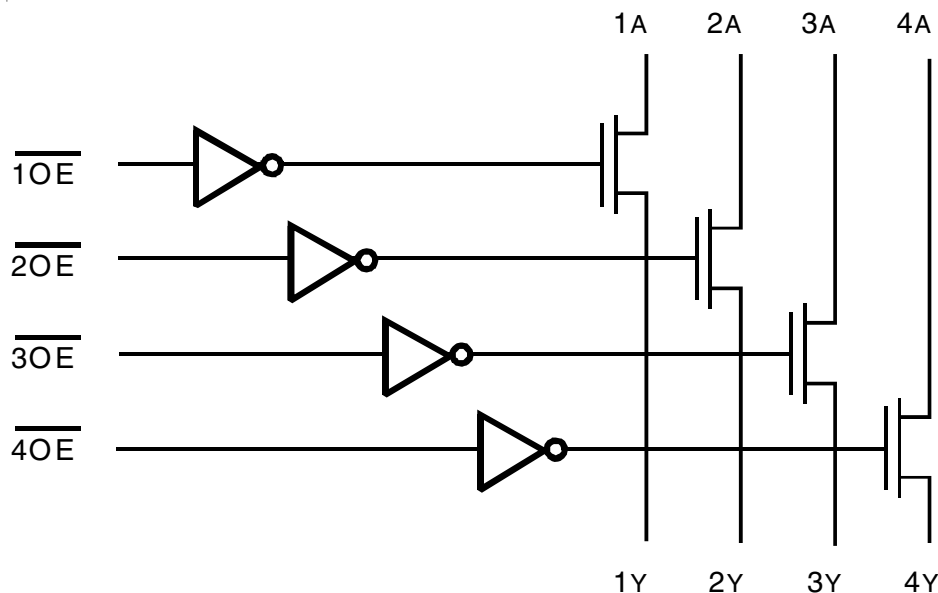

The IDT logo is a registered trademark of Integrated Device Technology, Inc.

**INDUSTRIAL TEMPERATURE RANGE**

**FEBRUARY 2011**

### PIN CONFIGURATION

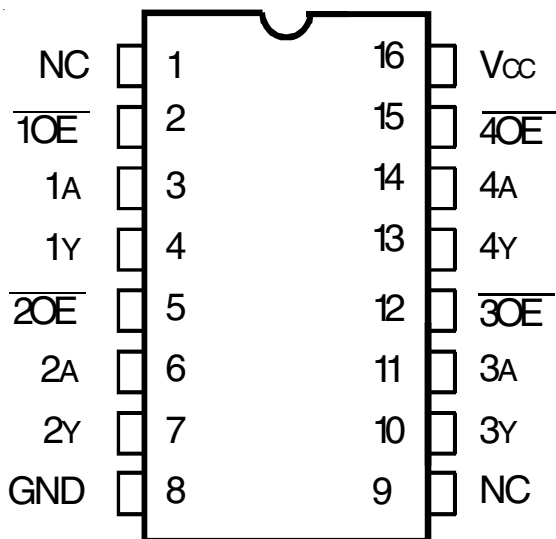

QSOP  
TOP VIEW

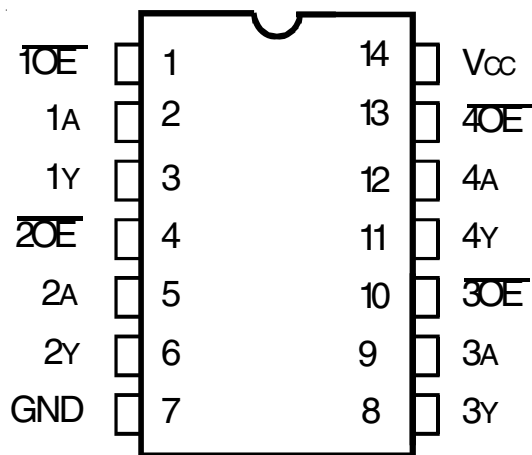

SOIC  
TOP VIEW

### ABSOLUTE MAXIMUM RATINGS(1)

Symbol	Description	Max	Unit
VTERM <sup>(2)</sup>	Supply Voltage to Ground	-0.5 to +7	V
VTERM <sup>(3)</sup>	DC Switch Voltage Vs	-0.5 to +7	V
VTERM <sup>(3)</sup>	DC Input Voltage VIN	-0.5 to +7	V
VAC	AC Input Voltage (pulse width ≤20ns)	-3	V
IOUT	DC Output Current	120	mA
PMAX	Maximum Power Dissipation (TA = 85°C)	0.5	W
TSTG	Storage Temperature	-65 to +150	°C

**NOTES:**

1. Stresses greater than those listed under ABSOLUTE MAXIMUM RATINGS may cause permanent damage to the device. This is a stress rating only and functional operation of the device at these or any other conditions above those indicated in the operational sections of this specification is not implied. Exposure to absolute maximum rating conditions for extended periods may affect reliability.
2. Vcc terminals.
3. All terminals except Vcc .

### CAPACITANCE (TA = +25°C, f = 1MHz, VIN = 0V, VOUT = 0V)

Pins	Typ.	Max. <sup>(1)</sup>	Unit
$\overline{OE}$ (Inputs)	3	5	pF
Quickswitch Channels (Switch OFF)	5	7	pF

**NOTE:**

1. This parameter is guaranteed but not production tested.

### PIN DESCRIPTION

Pin Names	I/O	Description
1A - 4A	I/O	Bus A
1Y - 4Y	I/O	Bus Y
$\overline{1OE}$ - $\overline{4OE}$	I	Bus Switch Enable

### FUNCTION TABLE(1)

$\overline{xOE}$	xA	xY	Function
L	H	H	Connect
L	L	L	Connect
H	X	X	Disconnect

**NOTE:**

1. H = HIGH Voltage Level  
L = LOW Voltage Level  
X = Don't Care

## DC ELECTRICAL CHARACTERISTICS OVER OPERATING RANGE

Following Conditions Apply Unless Otherwise Specified:

Industrial:  $T_A = -40^{\circ}\text{C}$  to  $+85^{\circ}\text{C}$ ,  $V_{CC} = 5\text{V} \pm 5\%$

Symbol	Parameter	Test Conditions	Min.	Typ. <sup>(1)</sup>	Max.	Unit
$V_{IH}$	Input HIGH Voltage	Guaranteed Logic HIGH for Control Inputs	2	—	—	V
$V_{IL}$	Input LOW Voltage	Guaranteed Logic LOW for Control Inputs	—	—	0.8	V
$I_{IN}$	Input Leakage Current (Control Inputs)	$0\text{V} \leq V_{IN} \leq V_{CC}$	—	—	$\pm 1$	$\mu\text{A}$
$I_{OZ}$	Off-State Current (Hi-Z)	$0\text{V} \leq V_{OUT} \leq V_{CC}$ , Switches OFF	—	—	$\pm 1$	$\mu\text{A}$
RON	Switch ON Resistance <sup>(2)</sup>	$V_{CC} = \text{Min.}$ , $V_{IN} = 0\text{V}$ , $I_{ON} = 30\text{mA}$	—	5	7	$\Omega$
		$V_{CC} = \text{Min.}$ , $V_{IN} = 2.4\text{V}$ , $I_{ON} = 15\text{mA}$	—	10	15	
VP	Pass Voltage <sup>(3)</sup>	$V_{IN} = V_{CC} = 5\text{V}$ , $I_{OUT} = -5\mu\text{A}$	3.7	4	4.2	V

**NOTES:**

1. Typical values are at  $V_{CC} = 5\text{V}$  and  $T_A = 25^{\circ}\text{C}$ .
2. RON is guaranteed but not production tested.
3. Pass voltage is guaranteed but not production tested.

### TYPICAL ON RESISTANCE vs VIN AT VCC = 5V

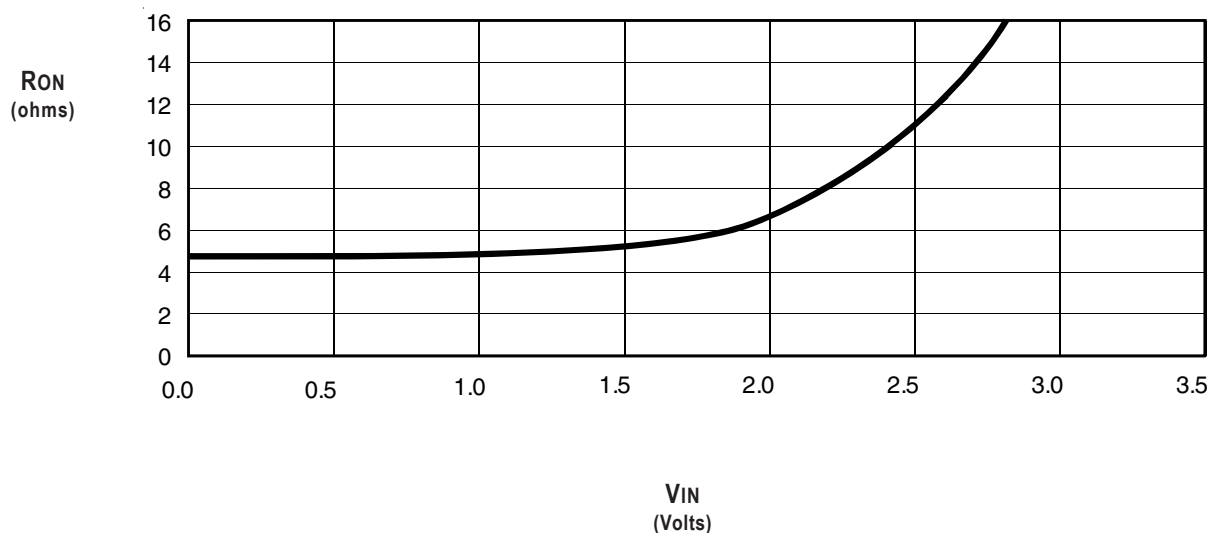

## POWER SUPPLY CHARACTERISTICS

Symbol	Parameter	Test Conditions <sup>(1)</sup>	Max.	Unit
I <sub>CCQ</sub>	Quiescent Power Supply Current	V <sub>CC</sub> = Max., V <sub>IN</sub> = GND or V <sub>CC</sub> , f = 0	3	μA
ΔI <sub>CC</sub>	Power Supply Current per Input HIGH <sup>(2)</sup>	V <sub>CC</sub> = Max., V <sub>IN</sub> = 3.4V, f = 0	2.5	mA
I <sub>CCD</sub>	Dynamic Power Supply Current per MHz <sup>(3)</sup>	V <sub>CC</sub> = Max., A and Y Pins Open, Control Inputs Toggling @ 50% Duty Cycle	0.25	mA/MHz

### NOTES:

- For conditions shown as Min. or Max., use the appropriate values specified under DC Electrical Characteristics.
- Per TTL-driven input (V<sub>IN</sub> = 3.4V, control inputs only). A and Y pins do not contribute to ΔI<sub>CC</sub>.
- This current applies to the control inputs only and represents the current required to switch internal capacitance at the specified frequency. The A and Y inputs generate no significant AC or DC currents as they transition. This parameter is guaranteed but not production tested.

## SWITCHING CHARACTERISTICS OVER OPERATING RANGE

T<sub>A</sub> = -40°C to +85°C, V<sub>CC</sub> = 5V ± 5%

C<sub>LOAD</sub> = 50pF, R<sub>LOAD</sub> = 500Ω unless otherwise noted.

Symbol	Parameter	Min. <sup>(1)</sup>	Typ.	Max.	Unit
t <sub>PLH</sub> t <sub>PHL</sub>	Data Propagation Delay <sup>(2)</sup> A to Y	—	—	0.25 <sup>(3)</sup>	ns
t <sub>PZL</sub> t <sub>PZH</sub>	Switch Turn-On Delay $\overline{OE}$ to xA/xY	1.5	—	6.5	ns
t <sub>PLZ</sub> t <sub>PHZ</sub>	Switch Turn-Off Delay <sup>(2)</sup> $\overline{OE}$ to xA/xY	1.5	—	5.5	ns

### NOTES:

- Minimums are guaranteed but not production tested.
- This parameter is guaranteed but not production tested.
- The bus switch contributes no propagation delay other than the RC delay of the ON resistance of the switch and the load capacitance. The time constant for the switch alone is of the order of 0.25ns at C<sub>L</sub> = 50pF. Since this time constant is much smaller than the rise and fall times of typical driving signals, it adds very little propagation delay to the system. Propagation delay of the bus switch, when used in a system, is determined by the driving circuit on the driving side of the switch and its interaction with the load on the driven side.

**ORDERING INFORMATION**

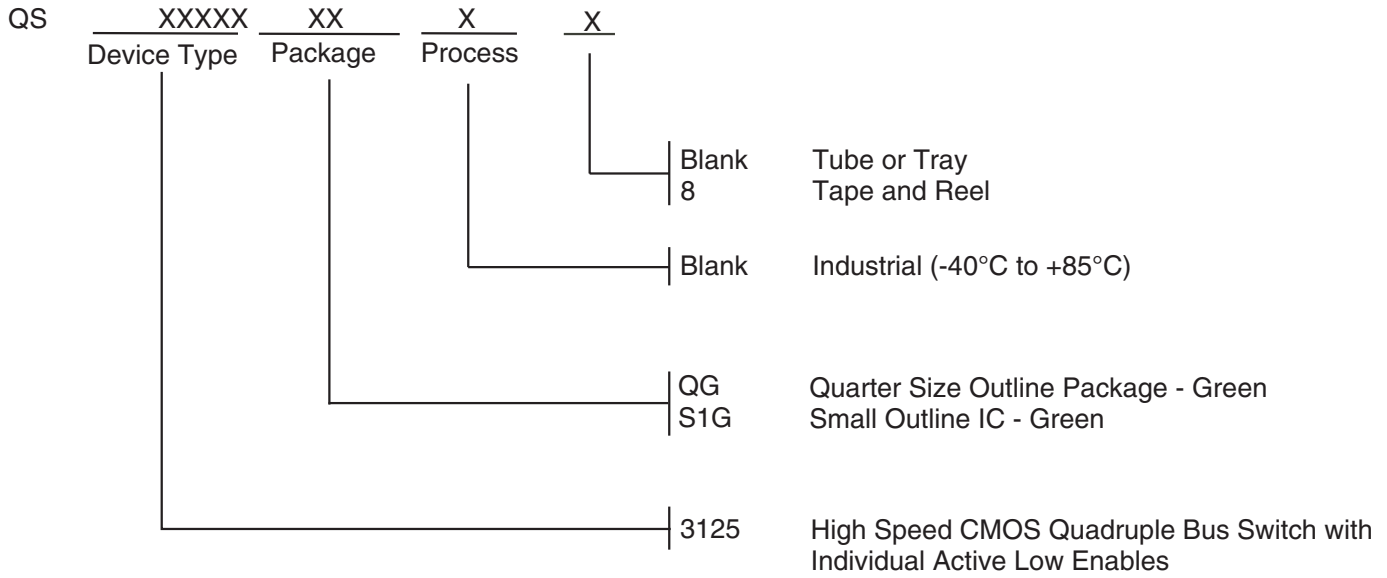

**Datasheet Document History**

02/08/2011 Pg. 5 Updated the ordering information by removing the "IDT" notation, non RoHS part and by adding Tape and Reel information.



**CORPORATE HEADQUARTERS**  
 6024 Silver Creek Valley Road  
 San Jose, CA 95138

**for SALES:**  
 800-345-7015 or 408-284-8200  
 fax: 408-284-2775  
 www.idt.com

**for Tech Support:**  
 logichelp@idt.com