

Eight Output Differential Buffer for PCI Express (50-200MHz)

ICS9DB801C

Description

The 9DB801C is a DB800 Version 2.0 Yellow Cover part with PCI Express support. It can be used in PC or embedded systems to provide outputs that have low cycle-to-cycle jitter (50ps), low output-to-output skew (100ps), and are PCI Express gen 1 compliant. The 9DB801C supports a 1 to 8 output configuration, taking a spread or non spread differential HCSL input from a CK410(B) main clock such as 954101 and 932S401, or any other differential HCSL pair. 9DB801C can generate HCSL or LVDS outputs from 50 to 200MHz in PLL mode or 0 to 400Mhz in bypass mode. There are two de-jittering modes available selectable through the HIGH_BW# input pin, high bandwidth mode provides de-jittering for spread inputs and low bandwidth mode provides extra de-jittering for non-spread inputs. The SRC_STOP#, PD#, and individual OE# real-time input pins provide completely programmable power management control.

Output Features

- 8 - 0.7V current-mode differential output pairs
- Supports zero delay buffer mode and fanout mode
- Bandwidth programming available

Features/Benefits

- Spread spectrum modulation tolerant, 0 to -0.5% down spread and +/- 0.25% center spread.
- Supports undriven differential outputs in PD# and SRC_STOP# modes for power management.
- Supports polarity inversion to the output enables, SRC_STOP and PD.

Key Specifications

- Outputs cycle-cycle jitter < 50ps
- Outputs skew: 50ps
- 50 - 200MHz operation
- Extended frequency range in bypass mode to 400 MHz
- PCI Express Gen I compliant
- Real time PLL lock detect output pin
- 48-pin SSOP/TSSOP package
- Available in RoHS compliant packaging

Functional Block Diagram

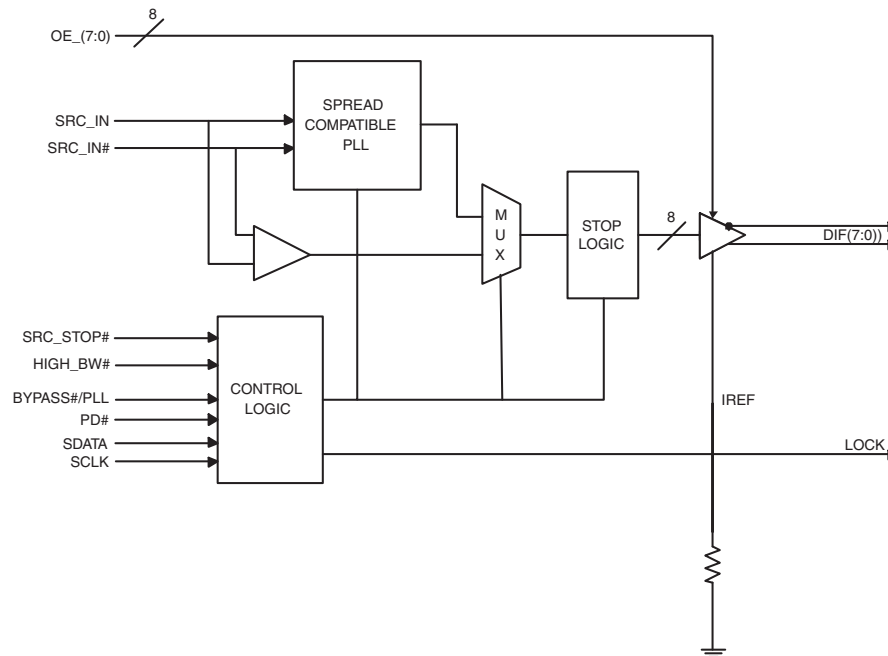

Note: Polarities shown for OE_INV = 0.

Pin Configuration

SRC_DIV#	1		48	VDDA
VDD	2		47	GNDA
GND	3		46	IREF
SRC_IN	4		45	LOCK
SRC_IN#	5		44	OE_7
OE_0	6		43	OE_4
OE_3	7		42	DIF_7
DIF_0	8		41	DIF_7#
DIF_0#	9		40	OE_INV
GND	10		39	VDD
VDD	11		38	DIF_6
DIF_1	12		37	DIF_6#
DIF_1#	13		36	OE_6
OE_1	14		35	OE_5
OE_2	15		34	DIF_5
DIF_2	16		33	DIF_5#
DIF_2#	17		32	GND
GND	18		31	VDD
VDD	19		30	DIF_4
DIF_3	20		29	DIF_4#
DIF_3#	21		28	HIGH_BW#
BYPASS#/PLL	22		27	SRC_STOP#
SCLK	23		26	PD#
SDATA	24		25	GND

ICS9DB801
(Same as ICS9DB108)

OE_INV = 0

SRC_DIV#	1		48	VDDA
VDD	2		47	GNDA
GND	3		46	IREF
SRC_IN	4		45	LOCK
SRC_IN#	5		44	OE7#
OE0#	6		43	OE4#
OE3#	7		42	DIF_7
DIF_0	8		41	DIF_7#
DIF_0#	9		40	OE_INV
GND	10		39	VDD
VDD	11		38	DIF_6
DIF_1	12		37	DIF_6#
DIF_1#	13		36	OE6#
OE1#	14		35	OE5#
OE2#	15		34	DIF_5
DIF_2	16		33	DIF_5#
DIF_2#	17		32	GND
GND	18		31	VDD
VDD	19		30	DIF_4
DIF_3	20		29	DIF_4#
DIF_3#	21		28	HIGH_BW#
BYPASS#/PLL	22		27	SRC_STOP
SCLK	23		26	PD
SDATA	24		25	GND

ICS9DB801

OE_INV = 1

Polarity Inversion Pin List Table

Pins	OE_INV	
	0	1
6	OE_0	OE0#
7	OE_3	OE3#
14	OE_1	OE1#
15	OE_2	OE2#
26	PD#	PD
27	DIF_STOP#	DIF_STOP
35	OE_5	OE5#
36	OE_6	OE6#
43	OE_4	OE4#
44	OE_7	OE7#

Pin Description for OE_INV = 0

PIN #	PIN NAME	PIN TYPE	DESCRIPTION
1	SRC_DIV#	INPUT	Active low Input for determining SRC output frequency SRC or SRC/2. 0 = SRC/2, 1= SRC
2	VDD	POWER	Power supply, nominal 3.3V
3	GND	POWER	Ground pin.
4	SRC_IN	INPUT	0.7 V Differential SRC TRUE input
5	SRC_IN#	INPUT	0.7 V Differential SRC COMPLEMENTARY input
6	OE_0	INPUT	Active high input for enabling outputs. 0 = tri-state outputs, 1= enable outputs
7	OE_3	INPUT	Active high input for enabling outputs. 0 = tri-state outputs, 1= enable outputs
8	DIF_0	OUTPUT	0.7V differential true clock outputs
9	DIF_0#	OUTPUT	0.7V differential complement clock outputs
10	GND	POWER	Ground pin.
11	VDD	POWER	Power supply, nominal 3.3V
12	DIF_1	OUTPUT	0.7V differential true clock outputs
13	DIF_1#	OUTPUT	0.7V differential complement clock outputs
14	OE_1	INPUT	Active high input for enabling outputs. 0 = tri-state outputs, 1= enable outputs
15	OE_2	INPUT	Active high input for enabling outputs. 0 = tri-state outputs, 1= enable outputs
16	DIF_2	OUTPUT	0.7V differential true clock outputs
17	DIF_2#	OUTPUT	0.7V differential complement clock outputs
18	GND	POWER	Ground pin.
19	VDD	POWER	Power supply, nominal 3.3V
20	DIF_3	OUTPUT	0.7V differential true clock outputs
21	DIF_3#	OUTPUT	0.7V differential complement clock outputs
22	BYPASS#/PLL	INPUT	Input to select Bypass(fan-out) or PLL (ZDB) mode 0 = Bypass mode, 1= PLL mode
23	SCLK	INPUT	Clock pin of SMBus circuitry, 5V tolerant.
24	SDATA	I/O	Data pin for SMBus circuitry, 5V tolerant.

Pin Description for OE_INV = 0

PIN #	PIN NAME	PIN TYPE	DESCRIPTION
25	GND	POWER	Ground pin.
26	PD#	INPUT	Asynchronous active low input pin, with 120Kohm internal pull-up resistor, used to power down the device. The internal clocks are disabled and the VCO and the crystal are stopped.
27	SRC_STOP#	INPUT	Active low input to stop SRC outputs.
28	HIGH_BW#	INPUT	3.3V input for selecting PLL Band Width 0 = High, 1= Low
29	DIF_4#	OUTPUT	0.7V differential complement clock outputs
30	DIF_4	OUTPUT	0.7V differential true clock outputs
31	VDD	POWER	Power supply, nominal 3.3V
32	GND	POWER	Ground pin.
33	DIF_5#	OUTPUT	0.7V differential complement clock outputs
34	DIF_5	OUTPUT	0.7V differential true clock outputs
35	OE_5	INPUT	Active high input for enabling outputs. 0 = tri-state outputs, 1= enable outputs
36	OE_6	INPUT	Active high input for enabling outputs. 0 = tri-state outputs, 1= enable outputs
37	DIF_6#	OUTPUT	0.7V differential complement clock outputs
38	DIF_6	OUTPUT	0.7V differential true clock outputs
39	VDD	POWER	Power supply, nominal 3.3V
40	OE_INV	INPUT	This latched input selects the polarity of the OE pins. 0 = OE pins active high, 1 = OE pins active low (OE#)
41	DIF_7#	OUTPUT	0.7V differential complement clock outputs
42	DIF_7	OUTPUT	0.7V differential true clock outputs
43	OE_4	INPUT	Active high input for enabling outputs. 0 = tri-state outputs, 1= enable outputs
44	OE_7	INPUT	Active high input for enabling outputs. 0 = tri-state outputs, 1= enable outputs
45	LOCK	OUTPUT	3.3V output indicating PLL Lock Status. This pin goes high when lock is achieved.
46	IREF	INPUT	This pin establishes the reference current for the differential current-mode output pairs. This pin requires a fixed precision resistor tied to ground in order to establish the appropriate current. 475 ohms is the standard value.
47	GNDA	POWER	Ground pin for the PLL core.
48	VDDA	POWER	3.3V power for the PLL core.

Pin Description for OE_INV = 1

PIN #	PIN NAME	PIN TYPE	DESCRIPTION
1	SRC_DIV#	INPUT	Active low Input for determining SRC output frequency SRC or SRC/2. 0 = SRC/2, 1= SRC
2	VDD	POWER	Power supply, nominal 3.3V
3	GND	POWER	Ground pin.
4	SRC_IN	INPUT	0.7 V Differential SRC TRUE input
5	SRC_IN#	INPUT	0.7 V Differential SRC COMPLEMENTARY input
6	OE0#	INPUT	Active low input for enabling DIF pair 0. 1 = tri-state outputs, 0 = enable outputs
7	OE3#	INPUT	Active low input for enabling DIF pair 3. 1 = tri-state outputs, 0 = enable outputs
8	DIF_0	OUTPUT	0.7V differential true clock outputs
9	DIF_0#	OUTPUT	0.7V differential complement clock outputs
10	GND	POWER	Ground pin.
11	VDD	POWER	Power supply, nominal 3.3V
12	DIF_1	OUTPUT	0.7V differential true clock outputs
13	DIF_1#	OUTPUT	0.7V differential complement clock outputs
14	OE1#	INPUT	Active low input for enabling DIF pair 1. 1 = tri-state outputs, 0 = enable outputs
15	OE2#	INPUT	Active low input for enabling DIF pair 2. 1 = tri-state outputs, 0 = enable outputs
16	DIF_2	OUTPUT	0.7V differential true clock outputs
17	DIF_2#	OUTPUT	0.7V differential complement clock outputs
18	GND	POWER	Ground pin.
19	VDD	POWER	Power supply, nominal 3.3V
20	DIF_3	OUTPUT	0.7V differential true clock outputs
21	DIF_3#	OUTPUT	0.7V differential complement clock outputs
22	BYPASS#/PLL	INPUT	Input to select Bypass(fan-out) or PLL (ZDB) mode 0 = Bypass mode, 1= PLL mode
23	SCLK	INPUT	Clock pin of SMBus circuitry, 5V tolerant.
24	SDATA	I/O	Data pin for SMBus circuitry, 5V tolerant.

Pin Description for OE_INV = 1

PIN #	PIN NAME	PIN TYPE	DESCRIPTION
25	GND	PWR	Ground pin.
26	PD	IN	Asynchronous active high input pin used to power down the device. The internal clocks are disabled and the VCO is stopped.
27	SRC_STOP	IN	Active high input to stop SRC outputs.
28	HIGH_BW#	IN	3.3V input for selecting PLL Band Width 0 = High, 1= Low
29	DIF_4#	OUT	0.7V differential complement clock outputs
30	DIF_4	OUT	0.7V differential true clock outputs
31	VDD	PWR	Power supply, nominal 3.3V
32	GND	PWR	Ground pin.
33	DIF_5#	OUT	0.7V differential complement clock outputs
34	DIF_5	OUT	0.7V differential true clock outputs
35	OE5#	IN	Active low input for enabling DIF pair 5. 1 = tri-state outputs, 0 = enable outputs
36	OE6#	IN	Active low input for enabling DIF pair 6. 1 = tri-state outputs, 0 = enable outputs
37	DIF_6#	OUT	0.7V differential complement clock outputs
38	DIF_6	OUT	0.7V differential true clock outputs
39	VDD	PWR	Power supply, nominal 3.3V
40	OE_INV	IN	This latched input selects the polarity of the OE pins. 0 = OE pins active high, 1 = OE pins active low (OE#)
41	DIF_7#	OUT	0.7V differential complement clock outputs
42	DIF_7	OUT	0.7V differential true clock outputs
43	OE4#	IN	Active low input for enabling DIF pair 4 1 = tri-state outputs, 0 = enable outputs
44	OE7#	IN	Active low input for enabling DIF pair 7. 1 = tri-state outputs, 0 = enable outputs
45	LOCK	OUT	3.3V output indicating PLL Lock Status. This pin goes high when lock is achieved.
46	IREF	IN	This pin establishes the reference current for the differential current-mode output pairs. This pin requires a fixed precision resistor tied to ground in order to establish the appropriate current. 475 ohms is the standard value.
47	GNDA	PWR	Ground pin for the PLL core.
48	VDDA	PWR	3.3V power for the PLL core.

Absolute Max

Symbol	Parameter	Min	Max	Units
VDD_A	3.3V Core Supply Voltage		4.6	V
VDD_In	3.3V Logic Supply Voltage		4.6	V
V _{IL}	Input Low Voltage	GND-0.5		V
V _{IH}	Input High Voltage		V _{DD} +0.5V	V
T _s	Storage Temperature	-65	150	°C
T _{ambient}	Ambient Operating Temp	0	70	°C
T _{case}	Case Temperature		115	°C
ESD prot	Input ESD protection human body model	2000		V

Electrical Characteristics - Input/Supply/Common Output ParametersT_A = 0 - 70°C; Supply Voltage V_{DD} = 3.3 V +/-5%

PARAMETER	SYMBOL	CONDITIONS	MIN	TYP	MAX	UNITS	NOTES
Input High Voltage	V _{IH}	3.3 V +/-5%	2		V _{DD} + 0.3	V	
Input Low Voltage	V _{IL}	3.3 V +/-5%	GND - 0.3		0.8	V	
Input High Current	I _{IH}	V _{IN} = V _{DD}	-5		5	uA	
Input Low Current	I _{IL1}	V _{IN} = 0 V; Inputs with no pull-up resistors	-5			uA	
	I _{IL2}	V _{IN} = 0 V; Inputs with pull-up resistors	-200			uA	
Operating Supply Current	I _{DD3.3PLL}	Full Active, C _L = Full load;		175	200	mA	
	I _{DD3.3BvPass}			160	175	mA	
Powerdown Current	I _{DD3.3PD}	all diff pairs driven		50	70	mA	
		all differential pairs tri-stated		1	4	mA	
Input Frequency	F _{iPLL}	PLL Mode	50		200	MHz	
Input Frequency	F _{iBypass}	Bypass Mode (Revision B/REV ID = 1H)	0		333.33	MHz	
Input Frequency	F _{iBypass}	Bypass Mode (Revision C/REV ID = 2H)	0		400	MHz	
Pin Inductance ¹	L _{pin}				7	nH	1
Input Capacitance ¹	C _{IN}	Logic Inputs	1.5		4	pF	1
	C _{OUT}	Output pin capacitance			4	pF	1
PLL Bandwidth	BW	PLL Bandwidth when PLL_BW=0	2.4	3	3.4	MHz	1
		PLL Bandwidth when PLL_BW=1	0.7	1	1.4	MHz	1
Clk Stabilization ^{1,2}	T _{STAB}	From V _{DD} Power-Up and after input clock stabilization or de-assertion of PD# to 1st clock		0.5	1	ms	1,2
Modulation Frequency	f _{MOD}	Triangular Modulation	30		33	kHz	1
Tdrive_SRC_STOP#		DIF output enable after SRC_Stop# de-assertion		10	15	ns	1,3
Tdrive_PD#		DIF output enable after PD# de-assertion			300	us	1,3
Tfall		Fall time of PD# and SRC_STOP#			5	ns	1
Trise		Rise time of PD# and SRC_STOP#			5	ns	2

¹Guaranteed by design and characterization, not 100% tested in production.²See timing diagrams for timing requirements.³Time from deassertion until outputs are >200 mV

Electrical Characteristics - Clock Input Parameters

$T_A = 0 - 70^\circ\text{C}$; Supply Voltage $V_{DD} = 3.3\text{ V} \pm 5\%$

PARAMETER	SYMBOL	CONDITIONS	MIN	MAX	UNITS	NOTES
Differential Input High Voltage	V_{IHDIF}	Differential inputs (single-ended measurement)	600	1150	mV	1
Differential Input Low Voltage	V_{ILDIF}	Differential inputs (single-ended measurement)	$V_{SS} - 300$	300	mV	1
Input Slew Rate - DIF_IN	dv/dt	Measured differentially	0.4	8	V/ns	2
Input Leakage Current	I_{IN}	$V_{IN} = V_{DD}, V_{IN} = \text{GND}$	-5	5	μA	1
Input Duty Cycle	d_{tin}	Measurement from differential waveform	45	55	%	1
Input SRC Jitter - Cycle to Cycle	SRCJ_{C2Cin}	Differential Measurement		125	ps	1

¹ Guaranteed by design and characterization, not 100% tested in production.

² Slew rate measured through V_{swing} centered around differential zero

Electrical Characteristics - DIF 0.7V Current Mode Differential Pair

$T_A = 0 - 70^\circ\text{C}$; $V_{DD} = 3.3\text{ V} \pm 5\%$; $C_L = 2\text{pF}$, $R_S = 33.2\Omega$, $R_P = 49.9\Omega$, $I_{REF} = 475\Omega$

PARAMETER	SYMBOL	CONDITIONS	MIN	TYP	MAX	UNITS	NOTES
Current Source Output Impedance	Z_o^1	$V_O = V_x$	3000			Ω	1
Voltage High	VHigh	Statistical measurement on single ended signal using oscilloscope math function.	660		850	mV	1,3
Voltage Low	VLow		-150		150		1,3
Max Voltage	Vovs	Measurement on single ended signal using absolute value.			1150	mV	1
Min Voltage	Vuds		-300				1
Crossing Voltage (abs)	Vcross(abs)		250		550	mV	1
Crossing Voltage (var)	d-Vcross	Variation of crossing over all edges			140	mV	1
Long Accuracy	ppm	see Tperiod min-max values			0	ppm	1,2
Rise Time	t_r	$V_{OL} = 0.175\text{V}, V_{OH} = 0.525\text{V}$	175		700	ps	1
Fall Time	t_f	$V_{OH} = 0.525\text{V}, V_{OL} = 0.175\text{V}$	175		700	ps	1
Rise Time Variation	$d-t_r$				125	ps	1
Fall Time Variation	$d-t_f$				125	ps	1
Duty Cycle	d_{t3}	Measurement from differential waveform	45		55	%	1
Skew	t_{sk3}	$V_T = 50\%$			50	ps	1
Jitter, Cycle to cycle	$t_{jyc-cyc}$	PLL mode, Measurement from differential waveform			50	ps	1
		BYPASS mode as additive jitter			50	ps	1

¹ Guaranteed by design and characterization, not 100% tested in production.

² All Long Term Accuracy and Clock Period specifications are guaranteed with the assumption that the input clock complies with CK409/CK410 accuracy requirements

³ $I_{REF} = V_{DD}/(3 \times R_R)$. For $R_R = 475\Omega$ (1%), $I_{REF} = 2.32\text{mA}$. $I_{OH} = 6 \times I_{REF}$ and $V_{OH} = 0.7\text{V}$ @ $Z_O = 50\Omega$.

SRC Reference Clock			
Common Recommendations for Differential Routing	Dimension or Value	Unit	Figure
L1 length, route as non-coupled 50ohm trace	0.5 max	inch	1
L2 length, route as non-coupled 50ohm trace	0.2 max	inch	1
L3 length, route as non-coupled 50ohm trace	0.2 max	inch	1
R_s	33	ohm	1
R_t	49.9	ohm	1

Down Device Differential Routing			
L4 length, route as coupled microstrip 100ohm differential trace	2 min to 16 max	inch	1
L4 length, route as coupled stripline 100ohm differential trace	1.8 min to 14.4 max	inch	1

Differential Routing to PCI Express Connector			
L4 length, route as coupled microstrip 100ohm differential trace	0.25 to 14 max	inch	2
L4 length, route as coupled stripline 100ohm differential trace	0.225 min to 12.6 max	inch	2

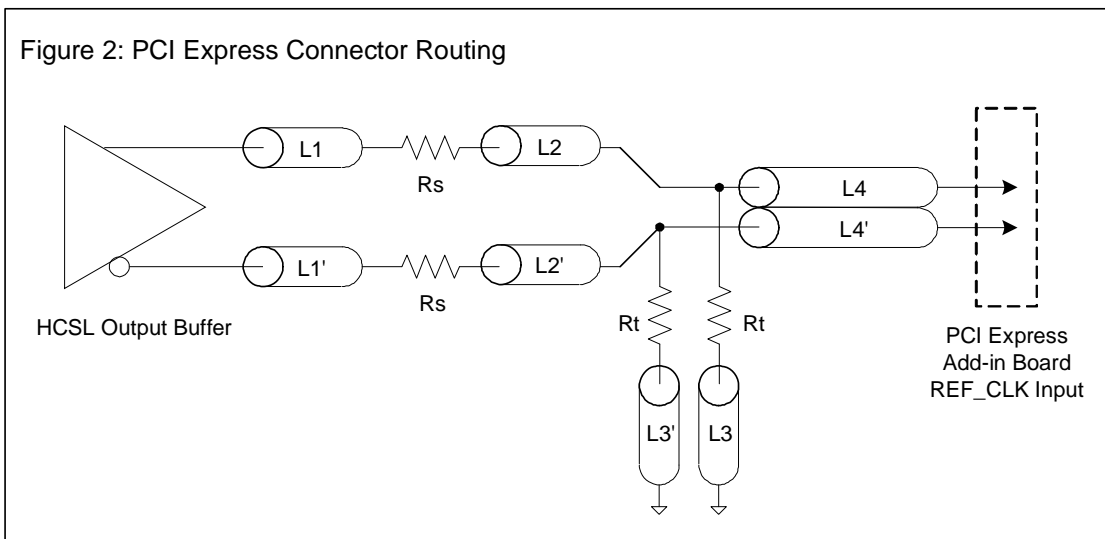
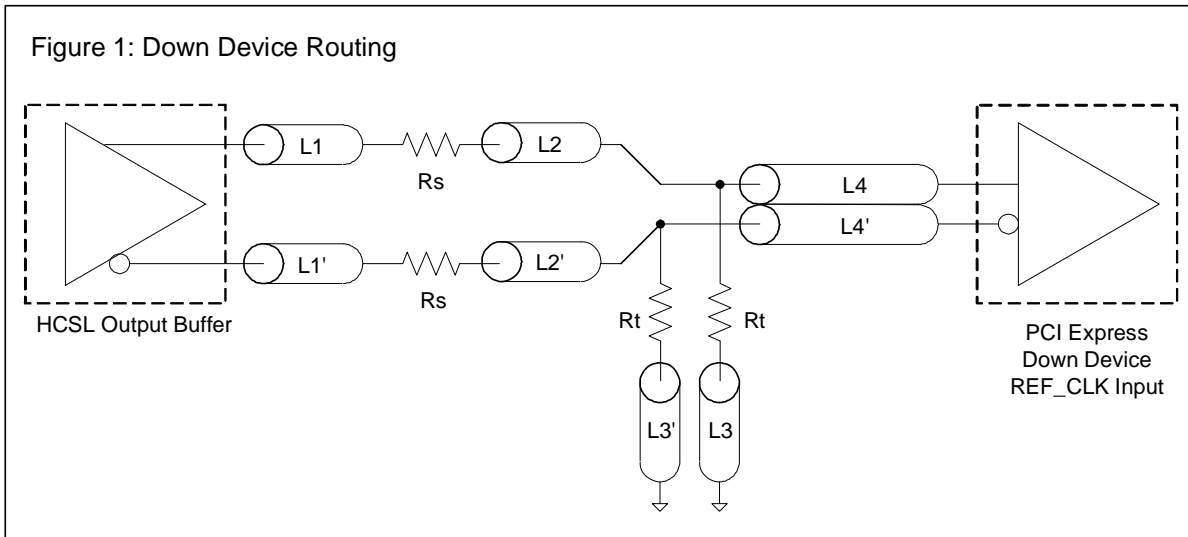

Alternative Termination for LVDS and other Common Differential Signals (figure 3)

V _{diff}	V _{p-p}	V _{cm}	R1	R2	R3	R4	Note
0.45v	0.22v	1.08	33	150	100	100	
0.58	0.28	0.6	33	78.7	137	100	
0.80	0.40	0.6	33	78.7	none	100	ICS874003i-02 input compatible
0.60	0.3	1.2	33	174	140	100	Standard LVDS

R1a = R1b = R1

R2a = R2b = R2

Figure 3

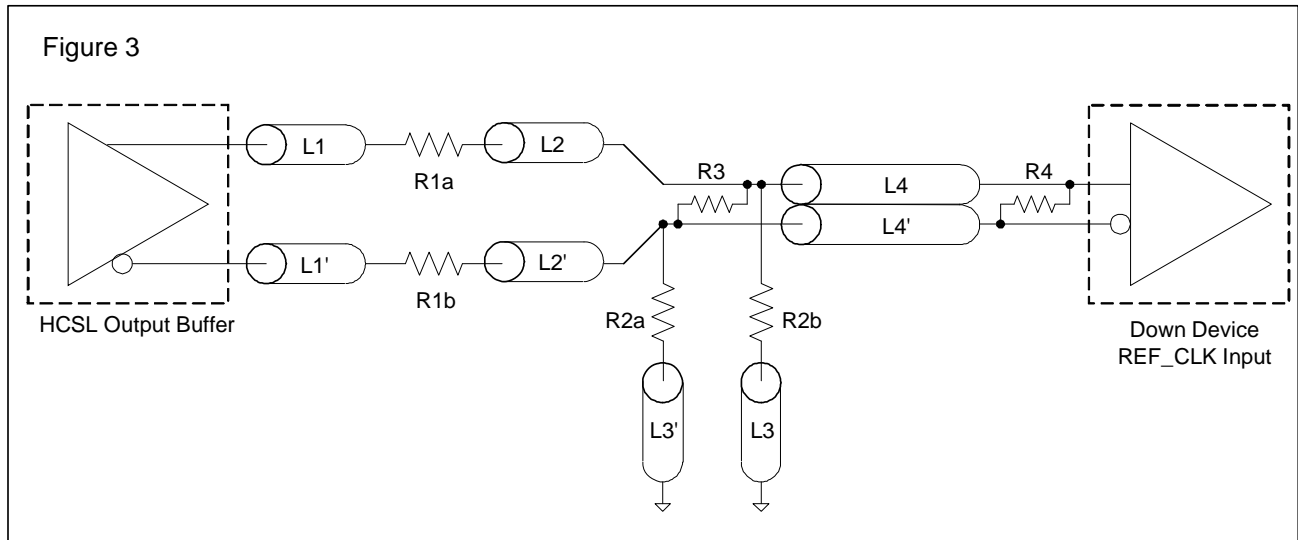

Cable Connected AC Coupled Application (figure 4)

Component	Value	Note
R5a, R5b	8.2K 5%	
R6a, R6b	1K 5%	
Cc	0.1 μ F	
V _{cm}	0.350 volts	

Figure 4

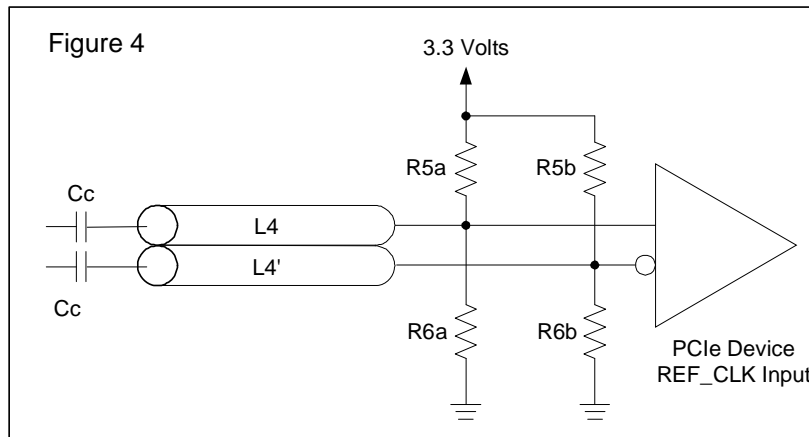

General SMBus serial interface information for the ICS9DB801C

How to Write:

- Controller (host) sends a start bit.
- Controller (host) sends the write address $DC_{(h)}$
- ICS clock will **acknowledge**
- Controller (host) sends the beginning byte location = N
- ICS clock will **acknowledge**
- Controller (host) sends the data byte count = X
- ICS clock will **acknowledge**
- Controller (host) starts sending **Byte N through Byte N + X - 1**
- ICS clock will **acknowledge** each byte **one at a time**
- Controller (host) sends a Stop bit

How to Read:

- Controller (host) will send start bit.
- Controller (host) sends the write address $DC_{(h)}$
- ICS clock will **acknowledge**
- Controller (host) sends the beginning byte location = N
- ICS clock will **acknowledge**
- Controller (host) will send a separate start bit.
- Controller (host) sends the read address $DD_{(h)}$
- ICS clock will **acknowledge**
- ICS clock will send the data byte count = X
- ICS clock sends **Byte N + X - 1**
- ICS clock sends **Byte 0 through byte X (if $X_{(h)}$ was written to byte 8).**
- Controller (host) will need to acknowledge each byte
- Controller (host) will send a not acknowledge bit
- Controller (host) will send a stop bit

Index Block Write Operation		
Controller (Host)		ICS (Slave/Receiver)
T	starT bit	
Slave Address $DC_{(h)}$		
WR	WRite	
		ACK
Beginning Byte = N		
		ACK
Data Byte Count = X		
		ACK
Beginning Byte N	X Byte	
○		ACK
○		○
○		○
○		○
Byte N + X - 1		
		ACK
P	stoP bit	

Index Block Read Operation		
Controller (Host)		ICS (Slave/Receiver)
T	starT bit	
Slave Address $DC_{(h)}$		
WR	WRite	
		ACK
Beginning Byte = N		
		ACK
RT	Repeat starT	
Slave Address $DD_{(h)}$		
RD	ReaD	
		ACK
		Data Byte Count = X
ACK		
ACK		Beginning Byte N
○		○
○		○
○		○
○		○
		Byte N + X - 1
N	Not acknowledge	
P	stoP bit	

SMBus Table: Frequency Select Register, READ/WRITE ADDRESS (DC/DD)

Byte 0	Pin #	Name	Control Function	Type	0	1	PWD
Bit 7	-	PD_Mode	PD# drive mode	RW	driven	Hi-Z	0
Bit 6	-	STOP_Mode	SRC_Stop# drive mode	RW	driven	Hi-Z	0
Bit 5	-	Reserved	Reserved	RW	Reserved		X
Bit 4	-	Reserved	Reserved	RW	Reserved		X
Bit 3	-	Reserved	Reserved	RW	Reserved		X
Bit 2	-	PLL_BW#	Select PLL BW	RW	High BW	Low BW	1
Bit 1	-	BYPASS#	BYPASS#/PLL	RW	fan-out	ZDB	1
Bit 0	-	SRC_DIV#	SRC Divide by 2 Select	RW	x/2	1x	1

SMBus Table: Output Control Register

Byte 1	Pin #	Name	Control Function	Type	0	1	PWD
Bit 7	42,41	DIF_7	Output Control	RW	Disable	Enable	1
Bit 6	38,37	DIF_6	Output Control	RW	Disable	Enable	1
Bit 5	34,33	DIF_5	Output Control	RW	Disable	Enable	1
Bit 4	30,29	DIF_4	Output Control	RW	Disable	Enable	1
Bit 3	20,21	DIF_3	Output Control	RW	Disable	Enable	1
Bit 2	16,17	DIF_2	Output Control	RW	Disable	Enable	1
Bit 1	12,13	DIF_1	Output Control	RW	Disable	Enable	1
Bit 0	8,9	DIF_0	Output Control	RW	Disable	Enable	1

SMBus Table: Output Control Register

Byte 2	Pin #	Name	Control Function	Type	0	1	PWD
Bit 7	42,41	DIF_7	Output Control	RW	Free-run	Stoppable	0
Bit 6	38,37	DIF_6	Output Control	RW	Free-run	Stoppable	0
Bit 5	34,33	DIF_5	Output Control	RW	Free-run	Stoppable	0
Bit 4	30,29	DIF_4	Output Control	RW	Free-run	Stoppable	0
Bit 3	20,21	DIF_3	Output Control	RW	Free-run	Stoppable	0
Bit 2	16,17	DIF_2	Output Control	RW	Free-run	Stoppable	0
Bit 1	12,13	DIF_1	Output Control	RW	Free-run	Stoppable	0
Bit 0	8,9	DIF_0	Output Control	RW	Free-run	Stoppable	0

SMBus Table: Output Control Register

Byte 3	Pin #	Name	Control Function	Type	0	1	PWD
Bit 7			Reserved	RW	Reserved		X
Bit 6			Reserved	RW	Reserved		X
Bit 5			Reserved	RW	Reserved		X
Bit 4			Reserved	RW	Reserved		X
Bit 3			Reserved	RW	Reserved		X
Bit 2			Reserved	RW	Reserved		X
Bit 1			Reserved	RW	Reserved		X
Bit 0			Reserved	RW	Reserved		X

SMBus Table: Vendor & Revision ID Register

Byte 4	Pin #	Name	Control Function	Type	0	1	PWD
Bit 7	-	RID3	REVISION ID	R	-	-	X
Bit 6	-	RID2		R	-	-	X
Bit 5	-	RID1		R	-	-	X
Bit 4	-	RID0		R	-	-	X
Bit 3	-	VID3	VENDOR ID	R	-	-	0
Bit 2	-	VID2		R	-	-	0
Bit 1	-	VID1		R	-	-	0
Bit 0	-	VID0		R	-	-	1

SMBus Table: DEVICE ID

Byte 5	Pin #	Name	Control Function	Type	0	1	PWD
Bit 7	-	Device ID 7 (MSB)		R	Reserved		1
Bit 6	-	Device ID 6		R	Reserved		0
Bit 5	-	Device ID 5		R	Reserved		0
Bit 4	-	Device ID 4		R	Reserved		0
Bit 3	-	Device ID 3		R	Reserved		0
Bit 2	-	Device ID 2		R	Reserved		0
Bit 1	-	Device ID 1		R	Reserved		0
Bit 0	-	Device ID 0		R	Reserved		1

SMBus Table: Byte Count Register

Byte 6	Pin #	Name	Control Function	Type	0	1	PWD
Bit 7	-	BC7	Writing to this register configures how many bytes will be read back.	RW	-	-	0
Bit 6	-	BC6		RW	-	-	0
Bit 5	-	BC5		RW	-	-	0
Bit 4	-	BC4		RW	-	-	0
Bit 3	-	BC3		RW	-	-	0
Bit 2	-	BC2		RW	-	-	1
Bit 1	-	BC1		RW	-	-	1
Bit 0	-	BC0		RW	-	-	1

Note: Polarities in timing diagrams are shown OE_INV = 0. They are similar to OE_INV = 1.

PD#, Power Down

The PD# pin cleanly shuts off all clocks and places the device into a power saving mode. PD# must be asserted before shutting off the input clock or power to insure an orderly shutdown. PD is asynchronous active-low input for both powering down the device and powering up the device. When PD# is asserted, all clocks will be driven high, or tri-stated (depending on the PD# drive mode and Output control bits) before the PLL is shut down.

PD# Assertion

When PD# is sampled low by two consecutive rising edges of DIF#, all DIF outputs must be held High, or tri-stated (depending on the PD# drive mode and Output control bits) on the next High-Low transition of the DIF# outputs. When the PD# drive mode bit is set to '0', all clock outputs will be held with DIF driven High with $2 \times I_{REF}$ and DIF# tri-stated. If the PD# drive mode bit is set to '1', both DIF and DIF# are tri-stated.

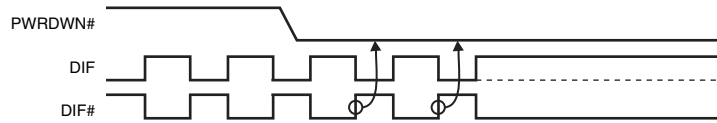

PD# De-assertion

Power-up latency is less than 1 ms. This is the time from de-assertion of the PD# pin, or VDD reaching 3.3V, or the time from valid SRC_IN clocks until the time that stable clocks are output from the device (PLL Locked). If the PD# drive mode bit is set to '1', all the DIF outputs must driven to a voltage of >200 mV within 300 us of PD# de-assertion.

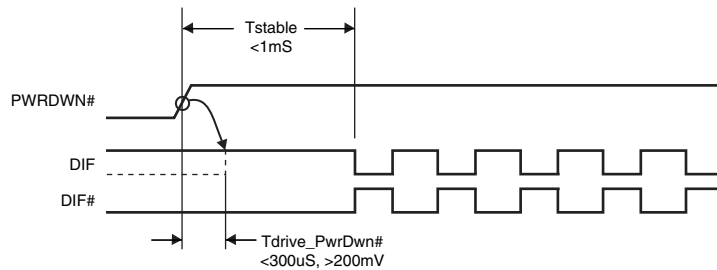

SRC_STOP#

The SRC_STOP# signal is an active-low asynchronous input that cleanly stops and starts the DIF outputs. A valid clock must be present on SRC_IN for this input to work properly. The SRC_STOP# signal is de-bounced and must remain stable for two consecutive rising edges of DIF# to be recognized as a valid assertion or de-assertion.

SRC_STOP# - Assertion

Asserting SRC_STOP# causes all DIF outputs to stop after their next transition (if the control register settings allow the output to stop). When the SRC_STOP# drive bit is '0', the final state of all stopped DIF outputs is DIF = High and DIF# = Low. There is no change in output drive current. DIF is driven with $6 \times I_{REF}$. DIF# is not driven, but pulled low by the termination. When the SRC_STOP# drive bit is '1', the final state of all DIF output pins is Low. Both DIF and DIF# are not driven.

SRC_STOP# - De-assertion (transition from '0' to '1')

All stopped differential outputs resume normal operation in a glitch-free manner. The de-assertion latency to active outputs is 2-6 DIF clock periods, with all DIF outputs resuming simultaneously. If the SRC_STOP# drive control bit is '1' (tri-state), all stopped DIF outputs must be driven High (>200 mV) within 10 ns of de-assertion.

SRC_STOP_1 (SRC_Stop = Driven, PD = Driven)

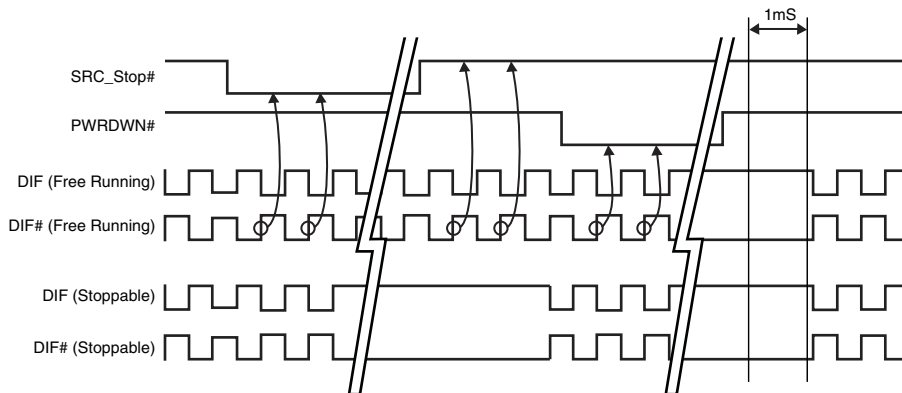

SRC_STOP_2 (SRC_Stop = Tristate, PD = Driven)

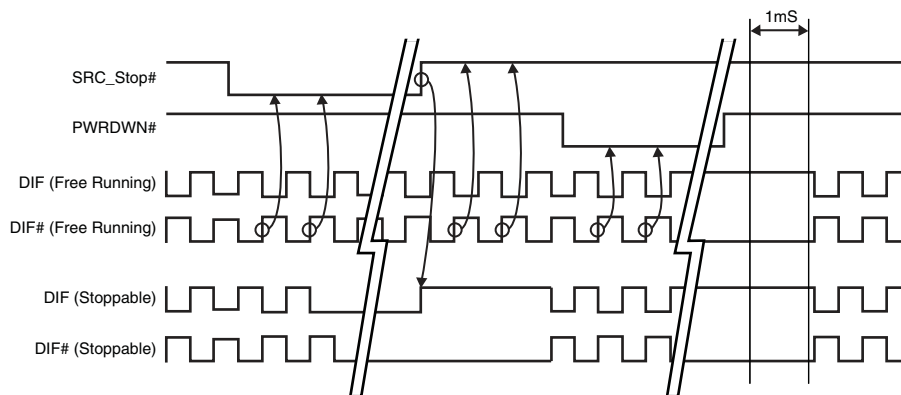

SRC_STOP_3 (SRC_Stop = Driven, PD = Tristate)

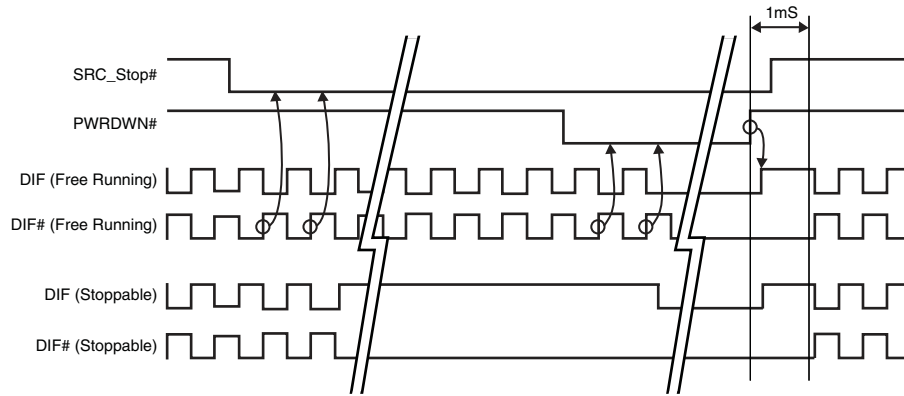

SRC_STOP_4 (SRC_Stop = Tristate, PD = Tristate)

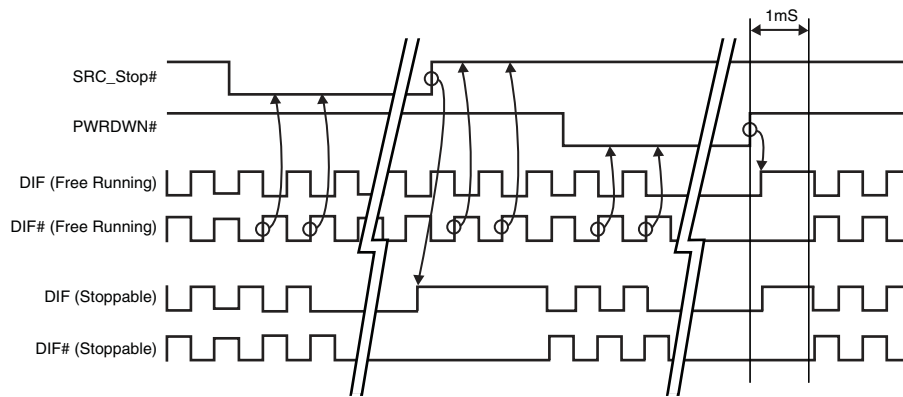

ICS9DB801C
Eight Output Differential Buffer for PCI Express (50-200MHz)

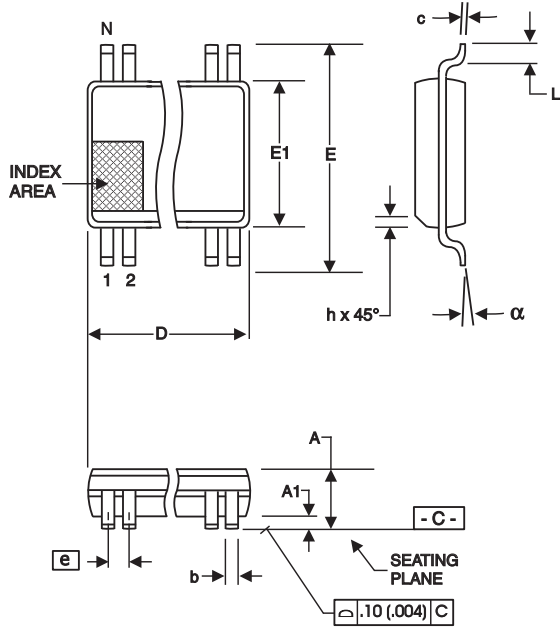

SYMBOL	In Millimeters		In Inches	
	COMMON DIMENSIONS	COMMON DIMENSIONS	COMMON DIMENSIONS	COMMON DIMENSIONS
	MIN	MAX	MIN	MAX
A	2.41	2.80	.095	.110
A1	0.20	0.40	.008	.016
b	0.20	0.34	.008	.0135
c	0.13	0.25	.005	.010
D	SEE VARIATIONS		SEE VARIATIONS	
E	10.03	10.68	.395	.420
E1	7.40	7.60	.291	.299
e	0.635 BASIC		0.025 BASIC	
h	0.38	0.64	.015	.025
L	0.50	1.02	.020	.040
N	SEE VARIATIONS		SEE VARIATIONS	
alpha	0°	8°	0°	8°

VARIATIONS

N	D mm.		D (inch)	
	MIN	MAX	MIN	MAX
48	15.75	16.00	.620	.630

Reference Doc.: JEDEC Publication 95, MO-118

10-0034

Ordering Information

9DB801CFLFT

Example:

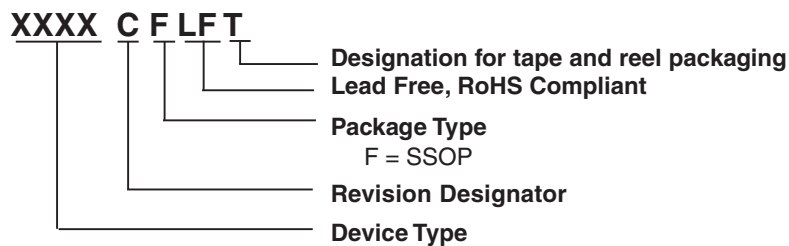

ICS9DB801C
Eight Output Differential Buffer for PCI Express (50-200MHz)

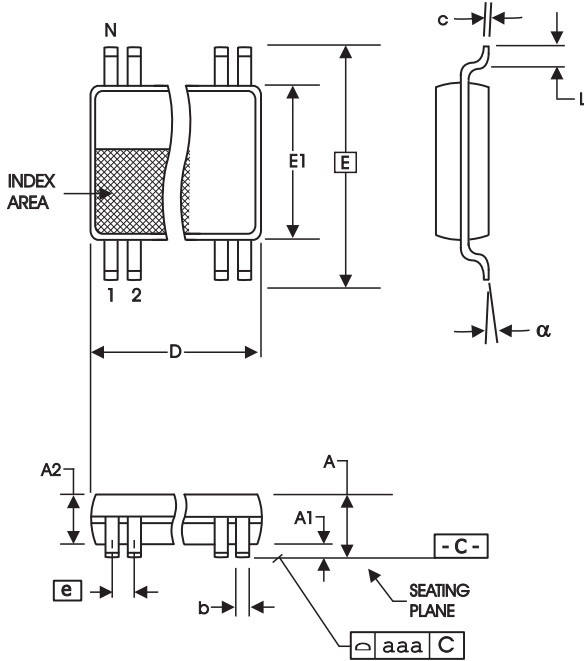

48-Lead, 6.10 mm. Body, 0.50 mm. Pitch TSSOP
(240 mil) (20 mil)

SYMBOL	In Millimeters COMMON DIMENSIONS		In Inches COMMON DIMENSIONS	
	MIN	MAX	MIN	MAX
A	--	1.20	--	.047
A1	0.05	0.15	.002	.006
A2	0.80	1.05	.032	.041
b	0.17	0.27	.007	.011
c	0.09	0.20	.0035	.008
D	SEE VARIATIONS		SEE VARIATIONS	
E	8.10 BASIC		0.319 BASIC	
E1	6.00	6.20	.236	.244
e	0.50 BASIC		0.020 BASIC	
L	0.45	0.75	.018	.030
N	SEE VARIATIONS		SEE VARIATIONS	
a	0°	8°	0°	8°
aaa	--	0.10	--	.004

VARIATIONS

N	D mm.		D (inch)	
	MIN	MAX	MIN	MAX
48	12.40	12.60	.488	.496

Reference Doc.: JEDEC Publication 95, MO-153

10-0039

Ordering Information

9DB801CGLFT

Example:

XXXX C G LFT

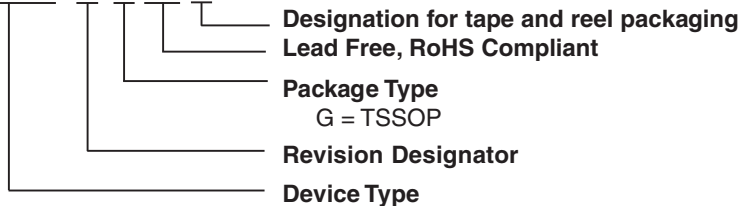

Revision History

Rev.	Issue Date	Description	Page #
A	4/8/2005	Release to Final	
B	9/7/2006	1. Added Polarity Table. 2. Updated Electrical Characteristics. 3. Updated LF Ordering Information from "Annealed Lead Free" to "RoHS Compliant".	1, 7, 16-17
C	2/29/2008	Added Input Clock Specs	8
D	12/3/2008	Removed ICS prefix from ordering information.	17-18
E	1/27/2011	Updated terminaton Figure 4.	10

Innovate with IDT and accelerate your future networks. Contact:

www.IDT.com

For Sales

800-345-7015
408-284-8200
Fax: 408-284-2775

For Tech Support

408-284-6578
pcclockhelp@idt.com

Corporate Headquarters

Integrated Device Technology, Inc.
6024 Silver Creek Valley Road
San Jose, CA 95138
United States
800 345 7015
+408 284 8200 (outside U.S.)

Asia Pacific and Japan

Integrated Device Technology
Singapore (1997) Pte. Ltd.
Reg. No. 199707558G
435 Orchard Road
#20-03 Wisma Atria
Singapore 238877
+65 6 887 5505

Europe

IDT Europe, Limited
Prime House
Barnett Wood Lane
Leatherhead, Surrey
United Kingdom KT22 7DE
+44 1372 363 339



www.IDT.com

Mouser Electronics

Authorized Distributor

Click to View Pricing, Inventory, Delivery & Lifecycle Information:

[IDT \(Integrated Device Technology\):](#)

[9DB801BGLFT](#) [9DB801BFLF](#) [9DB801BGLF](#) [9DB801CGLFT](#) [9DB801BFLFT](#) [9DB801CFLF](#) [9DB801CGLF](#)
[9DB801CFLFT](#)