



Evaluation Board

For XMC4000 Family

XMC4200 Platform2Go

Kit Version 1.1

Board User's Manual

Revision 2019-08-30

Microcontroller

Edition 2019-08-30

Published by

Infineon Technologies AG

81726 Munich, Germany

© 2019 Infineon Technologies AG

All Rights Reserved.

Legal Disclaimer

The information given in this document shall in no event be regarded as a guarantee of conditions or characteristics. With respect to any examples or hints given herein, any typical values stated herein and/or any information regarding the application of the device, Infineon Technologies hereby disclaims any and all warranties and liabilities of any kind, including without limitation, warranties of non-infringement of intellectual property rights of any third party.

Information

For further information on technology, delivery terms and conditions and prices, please contact the nearest Infineon Technologies Office (www.infineon.com).

Warnings

Due to technical requirements, components may contain dangerous substances. For information on the types in question, please contact the nearest Infineon Technologies Office.

Infineon Technologies components may be used in life-support devices or systems only with the express written approval of Infineon Technologies, if a failure of such components can reasonably be expected to cause the failure of that life-support device or system or to affect the safety or effectiveness of that device or system. Life support devices or systems are intended to be implanted in the human body or to support and/or maintain and sustain and/or protect human life. If they fail, it is reasonable to assume that the health of the user or other persons may be endangered.

Revision History

Page or Item	Subjects (major changes since previous revision)
Revision 2019-08-30	Initial Version

Trademarks of Infineon Technologies AG

AURIX™, C166™, CanPAK™, CIPOS™, CIPURSE™, EconoPACK™, CoolMOS™, CoolSET™, CORECONTROL™, CROSSAVE™, DAVE™, EasyPIM™, EconoBRIDGE™, EconoDUAL™, EconoPIM™, EiceDRIVER™, eupec™, FCOS™, HITFET™, HybridPACK™, I²RF™, ISOFACE™, IsoPACK™, MIPAQ™, ModSTACK™, my-d™, NovalithIC™, OptiMOS™, ORIGA™, PRIMARION™, PrimePACK™, PrimeSTACK™, PRO-SIL™, PROFET™, RASIC™, ReverSave™, SatRIC™, SIEGET™, SINDRION™, SIPMOS™, SmartLEWIS™, SOLID FLASH™, TEMPFET™, thinQ!™, TRENCHSTOP™, TriCore™.

Other Trademarks

Advance Design System™ (ADS) of Agilent Technologies, AMBA™, ARM™, MULTI-ICE™, KEIL™, PRIMECELL™, REALVIEW™, THUMB™, μVision™ of ARM Limited, UK. AUTOSAR™ is licensed by AUTOSAR development partnership. Bluetooth™ of Bluetooth SIG Inc. CAT-iq™ of DECT Forum. COLOSSUS™, FirstGPS™ of Trimble Navigation Ltd. EMV™ of EMVCo, LLC (Visa Holdings Inc.). EPCOS™ of Epcos AG. FLEXGO™ of Microsoft Corporation. FlexRay™ is licensed by FlexRay Consortium. HYPERTERMINAL™ of Hilgraeve Incorporated. IEC™ of Commission Electrotechnique Internationale. IrDA™ of Infrared Data Association Corporation. ISO™ of INTERNATIONAL ORGANIZATION FOR STANDARDIZATION. MATLAB™ of MathWorks, Inc. MAXIM™ of Maxim Integrated Products, Inc. MICROTEC™, NUCLEUS™ of Mentor Graphics Corporation. Mifare™ of NXP. MIPI™ of MIPI Alliance, Inc. MIPS™ of MIPS Technologies, Inc., USA. muRata™ of MURATA MANUFACTURING CO., MICROWAVE OFFICE™ (MWO) of Applied Wave Research Inc., OmniVision™ of OmniVision Technologies, Inc. Openwave™ Openwave Systems Inc. RED HAT™ Red Hat, Inc. RFMD™ RF Micro Devices, Inc. SIRIUS™ of Sirius Satellite Radio Inc. SOLARIS™ of Sun Microsystems, Inc. SPANSION™ of Spansion LLC Ltd. Symbian™ of Symbian Software Limited. TAIYO YUDEN™ of Taiyo Yuden Co. TEAKLITE™ of CEVA, Inc. TEKTRONIX™ of Tektronix Inc. TOKO™ of TOKO KABUSHIKI KAISHA TA. UNIX™ of X/Open Company Limited. VERILOG™, PALLADIUM™ of Cadence Design Systems, Inc. VLYNQ™ of Texas Instruments Incorporated. VXWORKS™, WIND RIVER™ of WIND RIVER SYSTEMS, INC. ZETEX™ of Diodes Zetex Limited.

Last Trademarks Update 2011-02-24

EtherCAT® is registered trademark and patented technology, licensed by Beckhoff Automation GmbH, Germany.

Table of Contents

1	Introduction	6
1.1	Key Features.....	7
1.2	Block Diagram	8
2	Hardware Description	8
2.1	Power Supply	11
2.2	Pin Header X1 and X2.....	12
2.3	Pin Header for Microbus and Shield2Go Connector 1 and 2	13
2.4	Solderable 0 Ohm Pin Bridges.....	14
2.5	Arduino Compatible Connector	15
2.6	User Push Buttons, Potentiometer and User LEDs	16
2.7	On-board Debug Probe	16
2.8	UART Communication for XMC4200.....	16
2.9	Cortex™ Debug Connector (10-pin)	16
2.10	Reset	17
2.11	CAN Transceiver	17
2.12	Boot Option.....	18
3	Production Data.....	18
3.1	Schematics	18
3.2	List of Material	24

List of Figures

Figure 1	Block Diagram of the XMC4200 Platform2Go Series-V1.1	8
Figure 2	XMC4200 Platform2Go 3.3V	9
Figure 3	XMC4200 Platform2Go 5V	9
Figure 4	XMC4200 Platform2Go 3.3V Lite	10
Figure 5	XMC4200 Platform2Go 5V Lite	10
Figure 6	Power Supply Concept	11
Figure 7	Signal mapping of the pin headers X1 and X2	12
Figure 8	Signal mapping of the pin headers for Microbus and Shield2Go Connector 1 and 2.....	13
Figure 9	Mapping of Arduino Functions to XMC Pin Functions.....	15
Figure 10	Connectors Schematic: Pin header, Pin Bridges, Level Shifter, Microbus, Shield2Go	19
Figure 11	XMC_4200_Debug Schematic: OBD Probe	20
Figure 12	XMC4200 Schematic: USB connector, Microcontroller pins and power, Potentiometer Button and LED	21

Table of Contents

Figure 13	ICs and Power Schematic: Can Transceiver, RTC Battery, Power	22
Figure 14	Geometry	23

List of Tables

Table 1	Kit Specification	6
Table 2	Kit Features of Assembly Versions.....	7
Table 3	Signal mapping of the 0 Ohm Pin Bridges	14
Table 4	XMC4200 Pin Mapping for User LEDs.....	16
Table 5	XMC4200 Pin Mapping for User Push Buttons and Potentiometer	16
Table 6	XMC4200 Pins Mapping for Debugging and UART-Communication	16
Table 7	Pin Assignment of the Cortex™ Debug Connector (X102).....	17
Table 8	CAN Signals and XMC4200 Pin Mapping.....	17
Table 9	Boot Mode Selection with external Pull Resistors	18
Table 10	List of Material	24

1 Introduction

This document describes the features and hardware details of the XMC4200 Platform2Go Series-V1.1 equipped with an ARM® Cortex®-M4 based XMC™ Microcontroller from Infineon Technologies AG.

It can be used with a wide range of development tools including Infineon's free of charge Eclipse based IDE DAVE. The XMC4200 Platform2Go Series-V1.1 are designed to evaluate the capabilities of the XMC4200 Microcontroller. Table 1 shows its specification.

Table 1 Kit Specification

Processor	Infineon's ARM® Cortex®-M4 XMC4200 Microcontroller in PG-LQFP-64-19 package (order number XMC4200-F64K256)
Flash Memory	256 kB Flash
Data Memory	40 kB
Dimensions	66 x 129 mm
Clock Crystals	<ul style="list-style-type: none"> • 12 MHz and 32.768 kHz crystal for CPU
Power	<ul style="list-style-type: none"> • 5V external powering • Micro-AB USB Connector interface or • On-Board Debugger USB interface
Connectors	<ul style="list-style-type: none"> • Arduino compatible connectors for 3.3V/5V • Two Shield2Go connectors • All relevant XMC™ pins available on expansion pads (X1, X2) • mikroBUS™ connector • 9-Position D-Sub Connector • microUSB • Serial Wire Debug interface (2x5, 50 mil pitch) to XMC™ (on board debugger can be overridden by externally connected debugger)
Debugger	<ul style="list-style-type: none"> • On-Board J-Link Debug Probe via USB supporting • Serial Wire Debug (SWD) • UART-to-USB bridge (virtual COM)
Others	<ul style="list-style-type: none"> • On-board debug probe, based on XMC4200 Microcontroller • CAN transceiver connected to D-Sub Connector • 1 user push-button, 1 user LED • Reset push-button • Potentiometer for variable analog input

The XMC4200 Platform2Go Series-V1.1 are available in four different assembly versions differentiating in features:

- XMC4200 Platform2Go for 3.3V Shields
- XMC4200 Platform2Go for 5V Shields
- XMC4200 Platform2Go Lite for 3.3V Shields
- XMC4200 Platform2Go Lite for 5V Shields

The **XMC4200 Platform2Go** features an Ethernet-enabled communication option. You can control the XMC4200 Platform2Go via the web browser on your PC.

Additional voltage level shifters and Arduino connection header on the XMC4200 Platform2Go allow the usage of **Arduino shields with 3.3V or 5V** logic level.

The Ethernet-communication is not supported by the **XMC4200 Platform2Go Lite Kit**, because some components e.g. for Ethernet are not assembled.

All boards are marked with “Platform2Go XMC4200-V1.1” and can be distinguished by the assembled devices (see pictures in chapter 2). These boards are neither cost nor size optimized and do not serve as a reference design.

1.1 Key Features

Table 2 summarizes the features of the different assembly versions of the XMC4200 Platform2Go Series-V1.1.

Table 2 Kit Features of Assembly Versions

Feature	XMC4200 Platform2Go 3.3V	XMC4200 Platform2Go 3.3V Lite	XMC4200 Platform2Go 5V	XMC4200 Platform2Go 5V Lite
XMC4200 Microcontroller	✓	✓	✓	✓
On-board Debug Probe with USB interface supporting SWD + SWO	✓	✓	✓	✓
Virtual COM Port via Debug Probe	✓	✓	✓	✓
1 x User Push-Button and 1 x User LED and 1 x Reset Push-Button 1 x Potentiometer	✓	✓	✓	✓
Voltage Regulator 5 V -> 3.3 V	✓	✓	✓	✓
USB (Micro USB Plug)	✓	✓	✓	✓
12 MHz Crystal	✓	✓	✓	✓
32.768 kHz RTC Crystal	✓		✓	
Arduino compatible connector 3.3 V / 5 V Arduino shields	✓	✓	✓	✓
0 Ohm Bridges Array for 3.3 V Arduino shields	✓	✓		
Voltage level shifter for 5 V Arduino			✓	✓
D-Sub Connector	✓		✓	
CAN Transceiver	✓		✓	

1.2 Block Diagram

The block diagram in Figure 1 shows the main components of the XMC4200 Platform2Go Series-V1.1 and their interconnections. There are following main building blocks:

- XMC4200 ontroller in a LQFP64 package
- On-board USB debug probe based on XMC4200 for SWD, SWV and Virtual COM Port support
- Two 40-pin header X1 and X2
- Connection Header for Arduino
- MikroBUS™ connector
- Two Infineon Shield2Go connectors (at the bottom of the board)
- Potentiometer (10kOhm)
- On-board power generation
- User Push-Button, User LED, Reset Push-Button
- Micro-AB USB Plug
- CAN Transceiver connected to 9-position D-Sub connector RS232

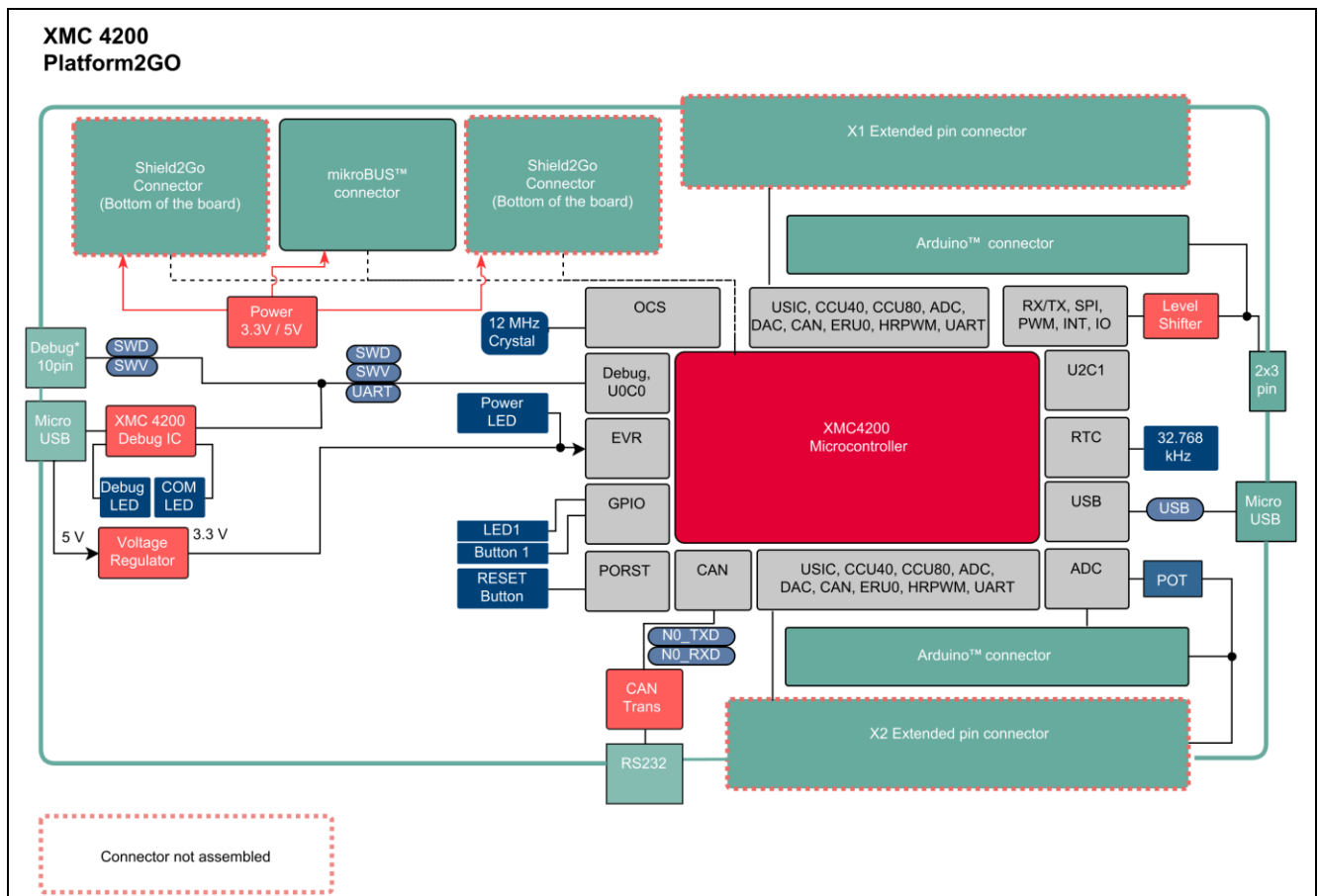

Figure 1 Block Diagram of the XMC4200 Platform2Go Series-V1.1

2 Hardware Description

The following chapters give a detailed description of the board hardware and how it can be used. The different assembly versions of the kits series are shown in Figure 2, Figure 3, Figure 4 and Figure 5.

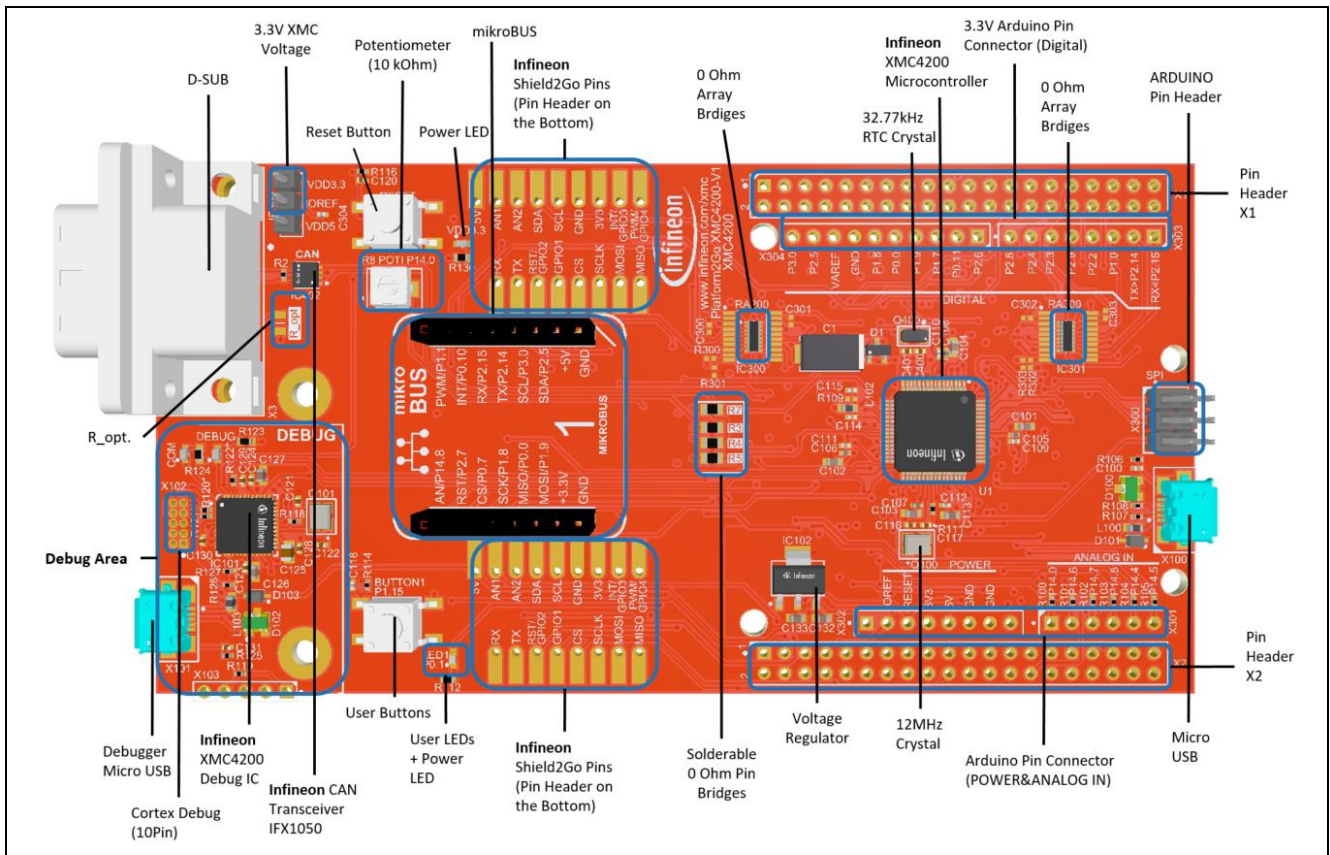

Figure 2 MXC4200 Platform2Go 3.3V

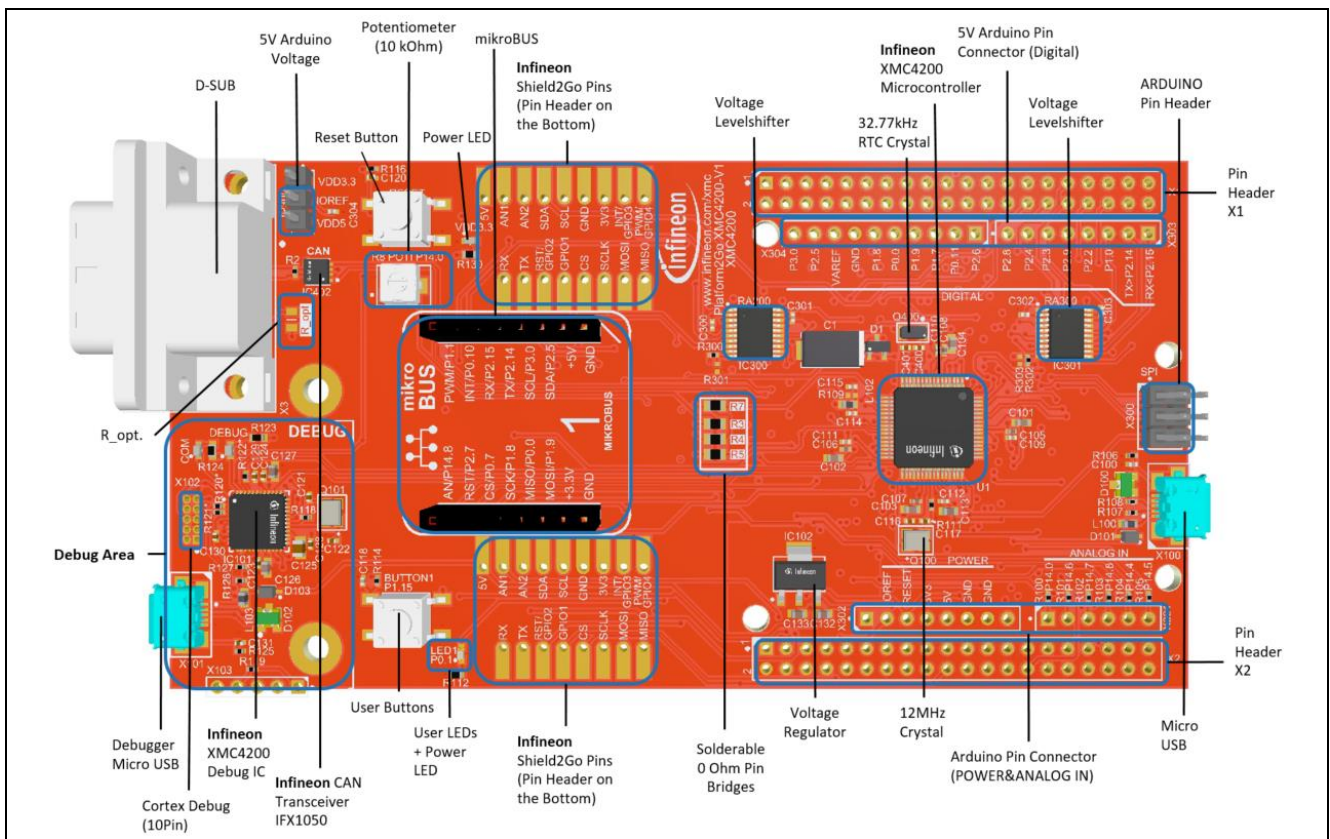

Figure 3 MXC4200 Platform2Go 5V

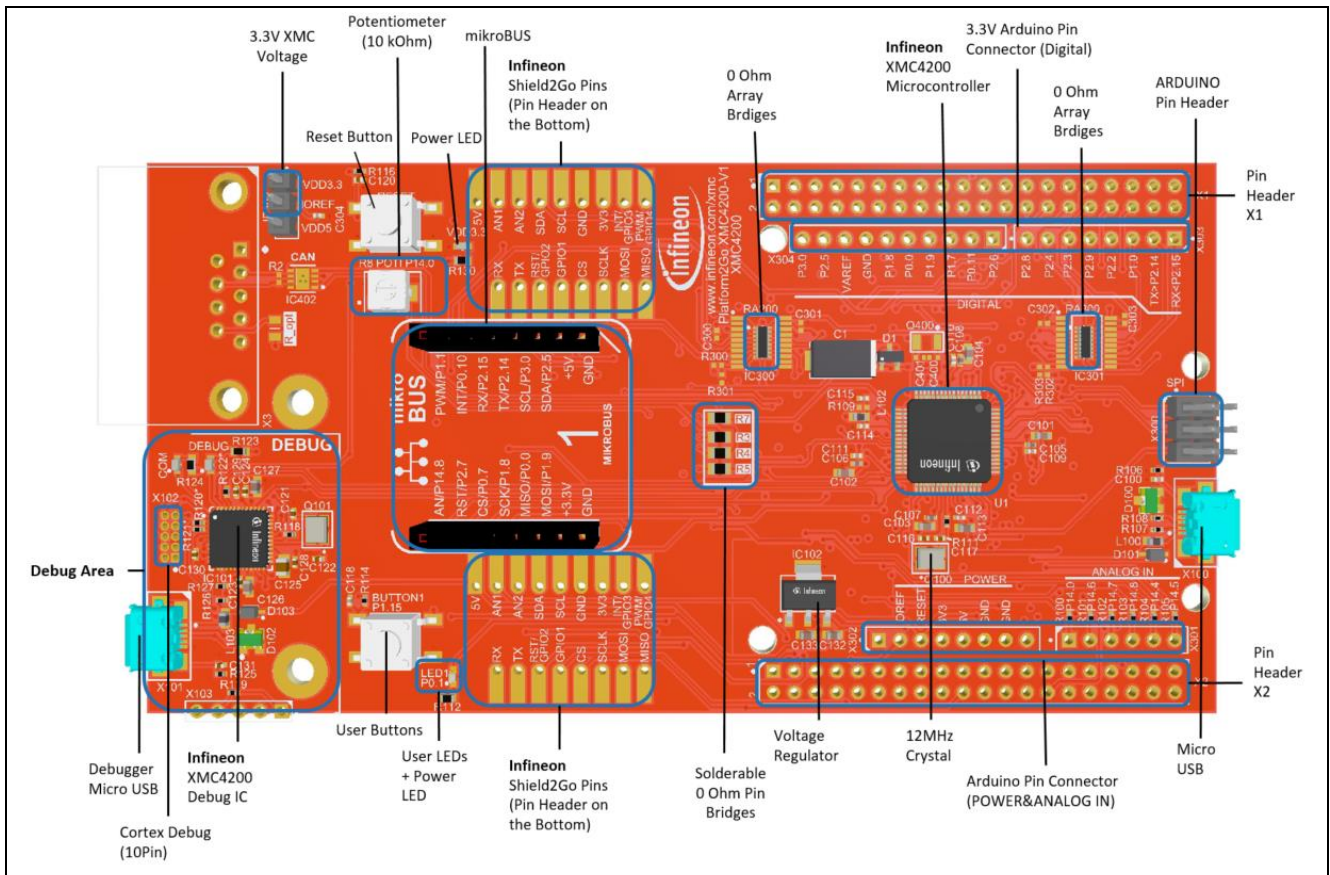

Figure 4 MXC4200 Platform2Go 3.3V Lite

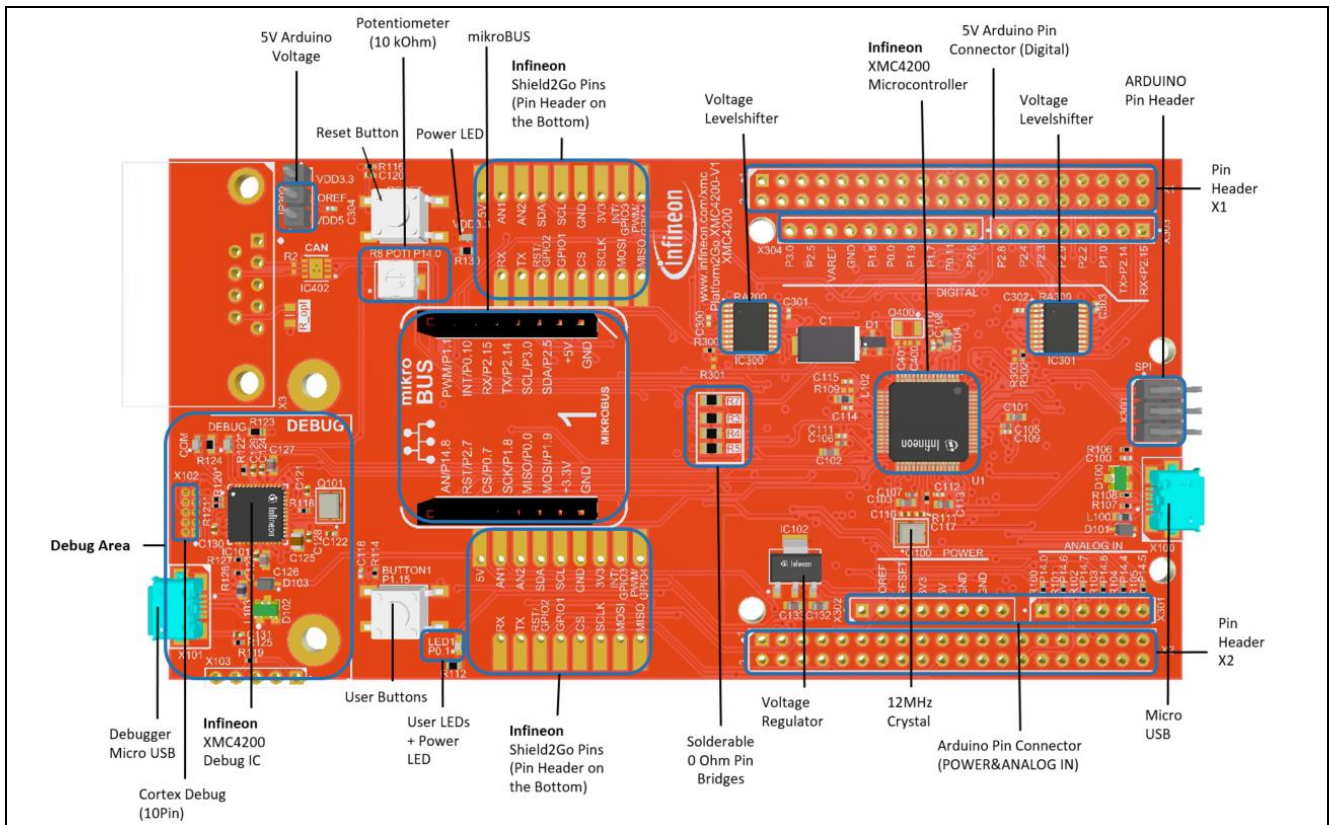

Figure 5 MXC4200 Platform2Go 5V Lite

2.1 Power Supply

The XMC4200 Platform2Go Series-V1.1 must be supplied by an external 5 Volt DC power supply connected to any of the micro USB plugs (X100, X101). The green Power LED (VDD3.3) indicates the presence of the generated 3.3 V supply voltage.

On-board reverse current protection diodes will ensure safe operation in case power is provided through both USB plugs at the same time. These protection diodes allows to use the on-board debug probe connected with a PC/Notebook via X101 and a second host PC/Laptop connected with the XMC4200 via X100.

If the board is powered via a USB plug, it's not recommended to apply an additional 5 Volt power supply to one of the 5 Volt power pins (VDD5, 5 V) on the pin headers X1 or X2 or the Arduino Power header, because there is no protection against reverse current into the external power supply. These power pins can be used to power an external circuit. But care must be taken not to draw more current than USB can deliver. A PC as USB host typically can deliver up to 500 mA current. If higher currents are required and in order to avoid damages on the USB host the use of an external USB power supply unit which is able to deliver higher currents than 500 mA is strongly recommended.

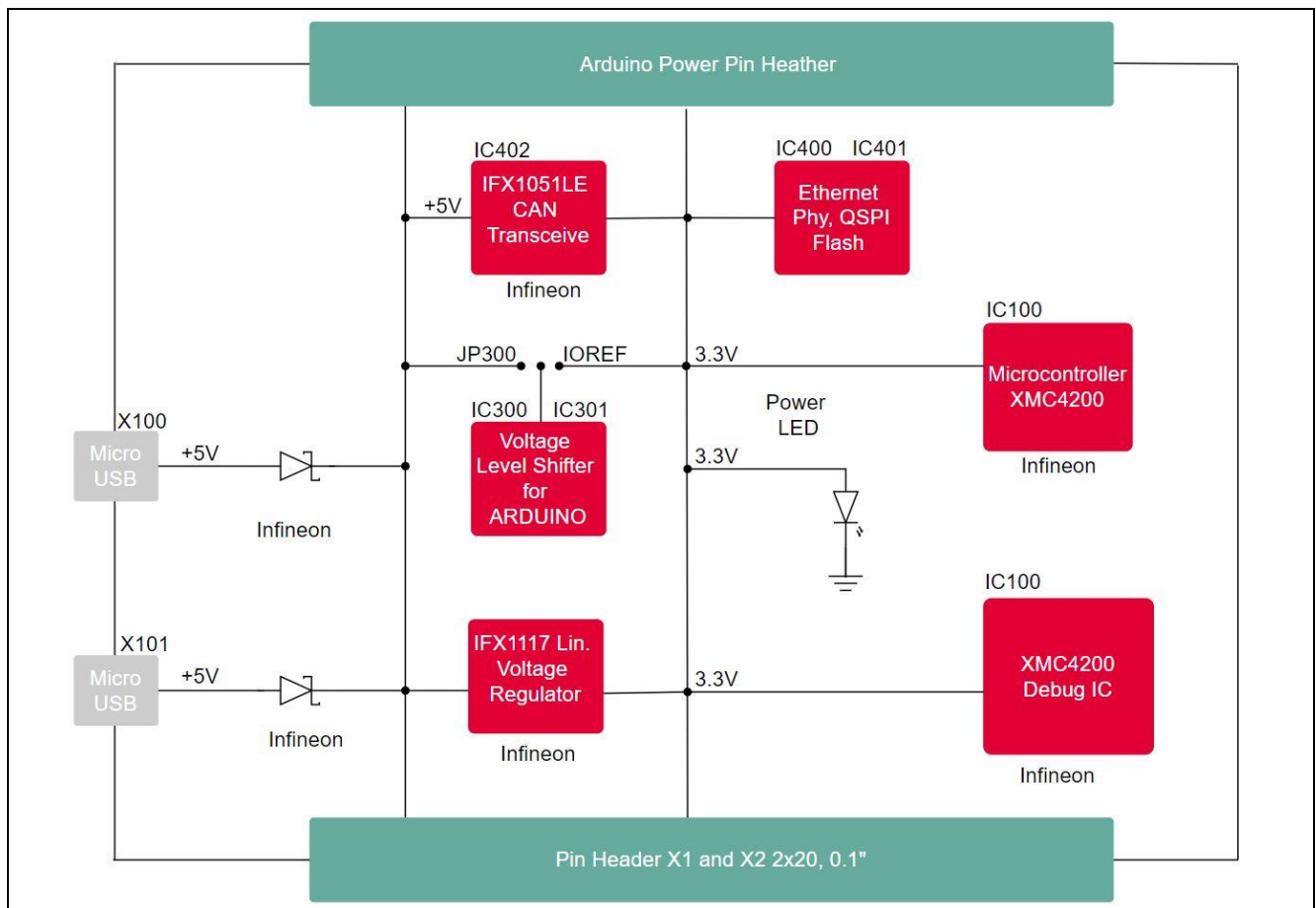

Figure 6 Power Supply Concept

2.2 Pin Header X1 and X2

The pin headers X1 and X2 can be used to extend the evaluation board or to perform measurements on the XMC4200. Figure 7 shows the available GPIOs / signals at these pin headers. The pin table is also printed onto the bottom side of the PCB in bottom view.

Pin Header X2				Pin Header X1							
	GND	2	1	P0.7	CS_MB	RESET#	2	1	GND		
RST/GPIO2_2GO_1	P0.8	4	3	NC		UART_RX	P2.15	4	3	P2.14	UART_TX
	NC	6	5	NC			NC	6	5	NC	
	NC	8	7	P0.11	PWM3	SPI_CS.PWM_4	P1.7	8	7	NC	
	NC	10	9	P0.5	INT/GPIO3_2GO_1	SPI_MOSI/PWM_5	P1.9	10	9	P1.8	SPI_CLK
RST/GPIO2_2GO_2	P0.6	12	11	P0.3	INT/GPIO3_2GO_2	PWM_MB	P1.1	12	11	P1.0	INT_0
GPIO1_S2GO_1	P0.4	14	13	P0.1	LED1	QSPI_IO2	P1.3	14	13	P1.2	PWM/GPIO4_2GO_1
CS_2GO_1	P0.2	16	15	P0.10	INT_MB	QSPI_IO0	P1.5	16	15	P1.4	PC_TXD
SPI_MISO	P0.0	18	17	NC			NC	18	17	NC	
CS_2GO_2	P0.9	20	19	P3.0	SCL, ADC_5		NC	20	19	NC	
	NC	22	21	P14.14	AN2_2GO	BUTTON1	P1.15*	22	21	NC	
SDA, ADC_4, AN1_2GO	P14.4	24	23	NC			NC	24	23	NC	
	NC	26	25	P14.6	ADC_1		NC	26	25		
ADC_2	P14.7	28	27	NC		RST_MB	P2.7	28	27	P2.6	IO_2
SCL, ADC_5, AN2_2GO	P14.5	30	29	NC		GPIO1_2GO_2	P2.1	30	29	P2.0*	CAN_TX
CAN_RX	P14.3*	32	31	NC		PWM_1	P2.3	32	31	P2.2	INT_1, PWM_0
ADC0/Potentiometer	P14.0	34	33	P14.8	AN_MB/DAC0	SDA, ADC_4	P2.5	34	33	P2.4	PWM_2
AN1_2GO/DAC1	P14.9	36	35	HIB_IO_0		IO_0	P2.9	36	35	P2.8	IO_1
VARREF		38	37	NC			NC	38	37	NC	
VDD3.3		40	39	#VBAT			VDD5	40	39	VDD3.3	

(Top View)

Figure 7 Signal mapping of the pin headers X1 and X2

*Note: These pins have solderable 0 Ohm (0805) resistor bridges. See section 2.4 and Table 3.

2.3 Pin Header for Microbus and Shield2Go Connector 1 and 2

The pin header for Microbus and Shield2Go Connector 1 and 2 can be used to extend the evaluation board or to perform measurements on the XMC4200. Figure 8 shows the available signals at these pin headers. The **Shield2Go pin header is mounted on the bottom**. The pin table is also printed onto the top and bottom side of the PCB in each view.

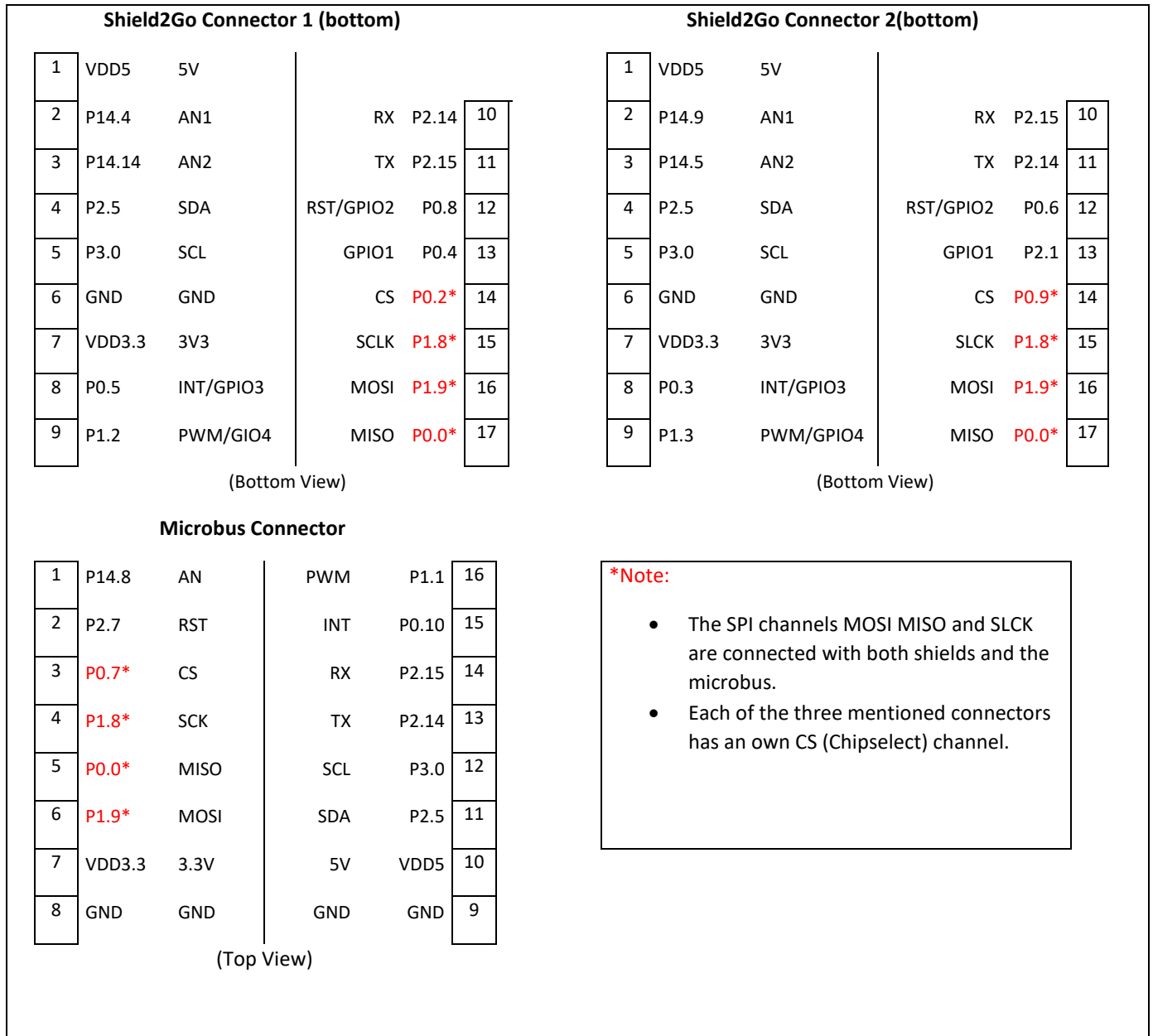

Figure 8 Signal mapping of the pin headers for Microbus and Shield2Go Connector 1 and 2

2.4 Solderable 0 Ohm Pin Bridges

The 0 Ohm (0805) pin bridges enable/disable the signal pins in Table 3 (enabled by default).

To disable the signals, their resistor has to be removed. The XMC4200 pins are then usable for other usages.

Table 3 Signal mapping of the 0 Ohm Pin Bridges

Resistor	XMC Pin	Signal
R3	P2.0	CAN_TX
R4	P14.3	CAN_RX
R5	P1.15	BUTTON1
R7	P14.0	Potentiometer
R112	P0.1	LED1

2.5 Arduino Compatible Connector

The mapping of GPIOs and XMC pin functions to Arduino compatible functions can be found in Figure 9. The Arduino compatible connector supports

- SPI interface (SPI_XXX)
- I2C interface (I2C_XXX)
- UART interface (UART_XXX)
- PWM signal outputs (PWM0-3)
- ADC input (ADC0-5)
- Interrupt input (INT0-1)

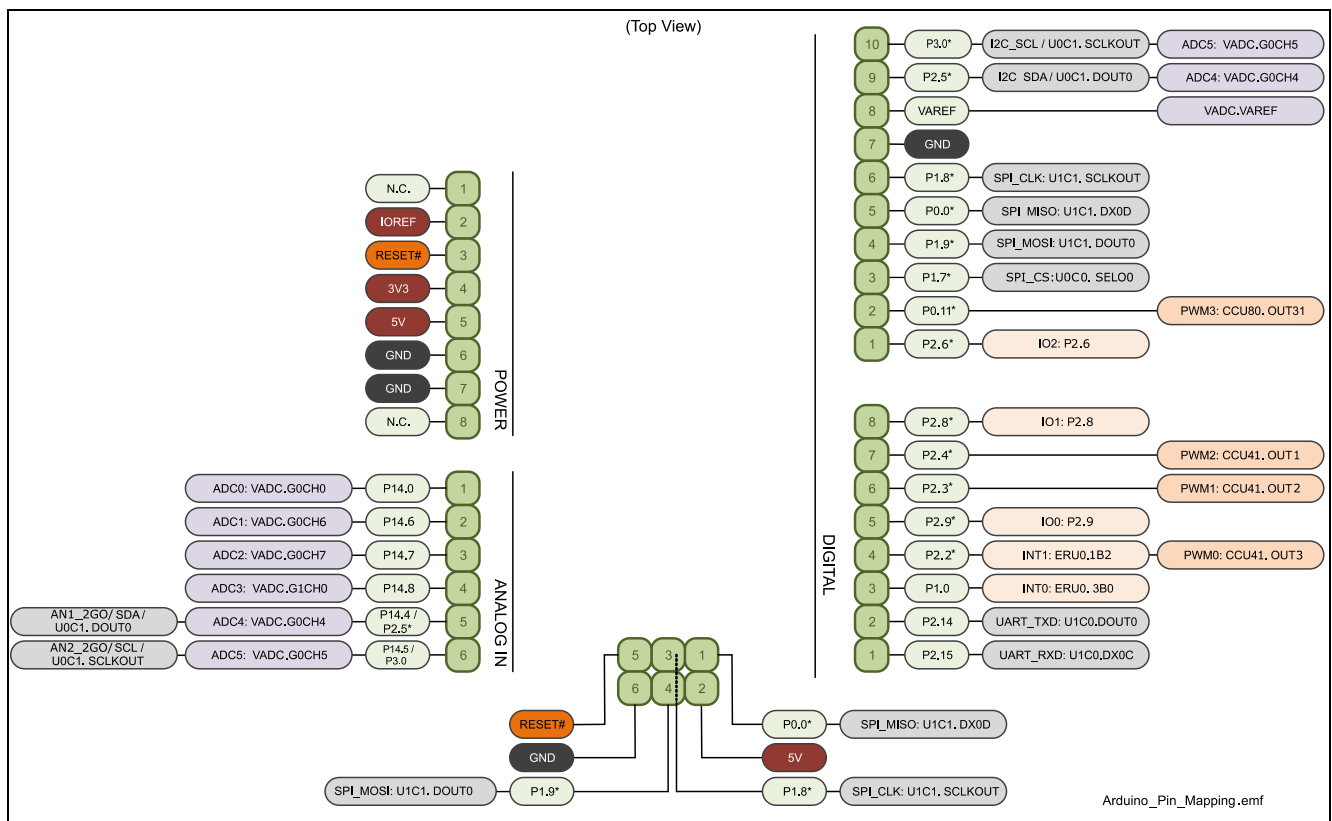

Figure 9 Mapping of Arduino Functions to XMC Pin Functions

The **XMC4200 Platform2Go 5V** features bi-directional voltage level shifter and therefore supports 5 V Arduino shields. Jumper JP300 (IOREF) determines whether the Arduino shield is driven with 5 V or 3.3 V.

Analog input signals ADC0-5 are limited to 3.3 V input voltage. Primarily ADC0 to ADC3 should be used as analog input, because there is no additional circuit connected to these pins, whereas ADC4 and ADC5 have additional circuitry and require an input signal with lower input impedance. ADC0 is also connected to the Potentiometer for a variable value of the analog input (optional see Table 5).

Note: Parallel operation of I2C and ADC4 / ADC5 is not possible, because they share the same Arduino pins.

2.6 User Push Buttons, Potentiometer and User LEDs

The XMC4200 Platform2Go Series-V1.1 provides one user push button, one LED and one Potentiometer. The port pins used can be found in Table 4 and Table 5.

Table 4 XMC4200 Pin Mapping for User LEDs

LED	XMC Pin	Resistor
LED1*	P0.1	R112 (680 Ohm)

Table 5 XMC4200 Pin Mapping for User Push Buttons and Potentiometer

Button	XMC Pin	Resistor
BUTTON1*	P1.15	R5
Potentiometer*	P14.0	R7

*Note: The push button, the potentiometer and the LED can be disabled by removing their designator. Also see Table 3.

Debugging and UART-to-USB Communication

The XMC4200 Platform2Go Series-V1.1 supports debugging via 2 different channels:

- On-board debug probe
- 10-pin Cortex™ Debug Connector (not assembled)

2.7 On-board Debug Probe

The on-board debug probe supports Serial Wire Debug (SWD) and UART communication. Both require the installation of Segger's J-Link Driver which is part of the DAVE™ installation. DAVE™ is a highly efficient development platform for the XMC microcontroller families to simplify and shorten SW development. It can be downloaded at www.infineon.com/dave. The latest Segger J-Link Driver can be downloaded at <http://www.segger.com/jlink-software.html>. Table 6 shows the pin assignment of the XMC4200 used for debugging and UART communication.

2.8 UART Communication for XMC4200

Table 6 XMC4200 Pins Mapping for Debugging and UART-Communication

Pin Function	Input/Output	XMC Pin
Data pin for Debugging via SWD	I/O	TMS
Clock pin for Debugging via SWD	O	TCK
Transmit pin for UART communication (PC_RX)	O	XMC4200 Debugger P1.5 (TXD_U0C0.DOUT0)
Receive pin for UART communication (PC_TX)	I	XMC4200 Debugger P1.4 (RXD_U0C0.DX0B)
Transmit pin for UART(UART_RX)	O	XMC4200 P2.15(RXD_U1C0.DX0C)
Receive pin for UART(UART_TX)	I	XMC4200 P2.14(TXD_U1C0.DOUT0)

2.9 Cortex™ Debug Connector (10-pin)

The 10-pin Cortex™ Debug Connector supports Serial Wire Debug (SWD) and Serial Wire Viewer (SWV). The pin assignment of the Cortex™ Debug Connector is shown in Table 6.

Table 7 Pin Assignment of the Cortex™ Debug Connector (X102)

Pin No.	Signal Name	Description
1	VCC	+3.3 V
2	TMS	Serial Wire Data I/O
3	GND	Ground
4	TCK	Serial Wire Clock
5	GND	Ground
6	SWV	Serial Wire Viewer (Trace Data Out)
7	NC	Not connected
8	NC	Not connected
9	GND_Detect	Ground detect
10	RESET	Rest (active low)

2.10 Reset

The reset pin (PORST#) of the XMC4200 is a bi-directional pin in open drain mode. An internal pull-up resistor keeps the PORST# pin high during normal operation. A low level at this pin will force a hardware reset. In case of a MCU internal reset the PORST# pin will drive a low signal.

A reset signal can be issued by

- the on-board Reset Button (“RESET”)
- the on-board debug probe (IC101.47)
- the external debugger connected to the 10-pin Cortex™ Debug probe connector (X102)
- the Arduino Power Header (X302.3, “RESET#”)
- the pin header X1 (X1.2, “RESET#”)

An XMC™ internal circuit always ensures a save Power-on-Reset. XMC™ does not require any additional external components to generate a reset signal during power-up.

2.11 CAN Transceiver

The XMC4200 Platform2Go provides a CAN interface via X3, a D-Sub DE-9, and the X1 and X2 connector. Infineon’s high speed CAN transceiver (IFX1051LE) for industrial applications supports 3.3V I/O logic and is suitable for 12 V and 24 V bus systems with an excellent EMC performance. The CAN bus (signals CANH, CANL) are terminated by a 120 Ohm resistor and can provide 5V if R_opt is assembled with a 0 Ohm 0805 resistor (not assembled by default). The other CAN bus (CAN_TX, CAN_RX) is not terminated by a 120 Ohm and needs to be terminated externally. To use the CAN_TX/RX pins otherwise see also Table 3.

Table 8 CAN Signals and XMC4200 Pin Mapping

Signal Name	Pin No. at Pin Header	XMC Pin, XMC Function
CANH	X3.7	-
CANL	X3.2	-
CAN_TX	X2.34	P2.0, CAN_TX
CAN_RX	X1.29	P14.0, CAN_RX
GND	X3.3, X3.6	-
VDD5	X3.9	-

2.12 Boot Option

During power-on-reset the XMC4200 latches the signal level at the pins TMS and TCK. Based on the logic levels latched at these pins after reset the XMC4200 starts booting in different modes. TMS and TCK pins are used for debugging and by default program execution is always starting from on-chip flash (normal mode).

The XMC4200 Platform2Go Series-V1.1 does not support the selection of the boot options by switches directly. In case of no external debug probe is used the boot mode can be influenced by applying 1 kOhm pull-up- or pull-down resistors to TMS and TCK pins. These pins are available at the 10-pin debug connector X102.

Table 9 Boot Mode Selection with external Pull Resistors

Logic Level at TMS during Reset	Logic Level at TCK during Reset	Boot Mode
High	Low	Normal Mode (boot from on-chip flash) (DEFAULT)
Low	Low	ASC BSL Mode (boot from UART)
High	High	BMI Customized Boot Mode
Low	High	CAN BSL Mode (boot from CAN)

3 Production Data

This chapter covers schematics, board dimensions, component placement and the list of material.

3.1 Schematics

In the following figures shows the schematics of the XMC4200 Platform2Go Series-V1.1 in.

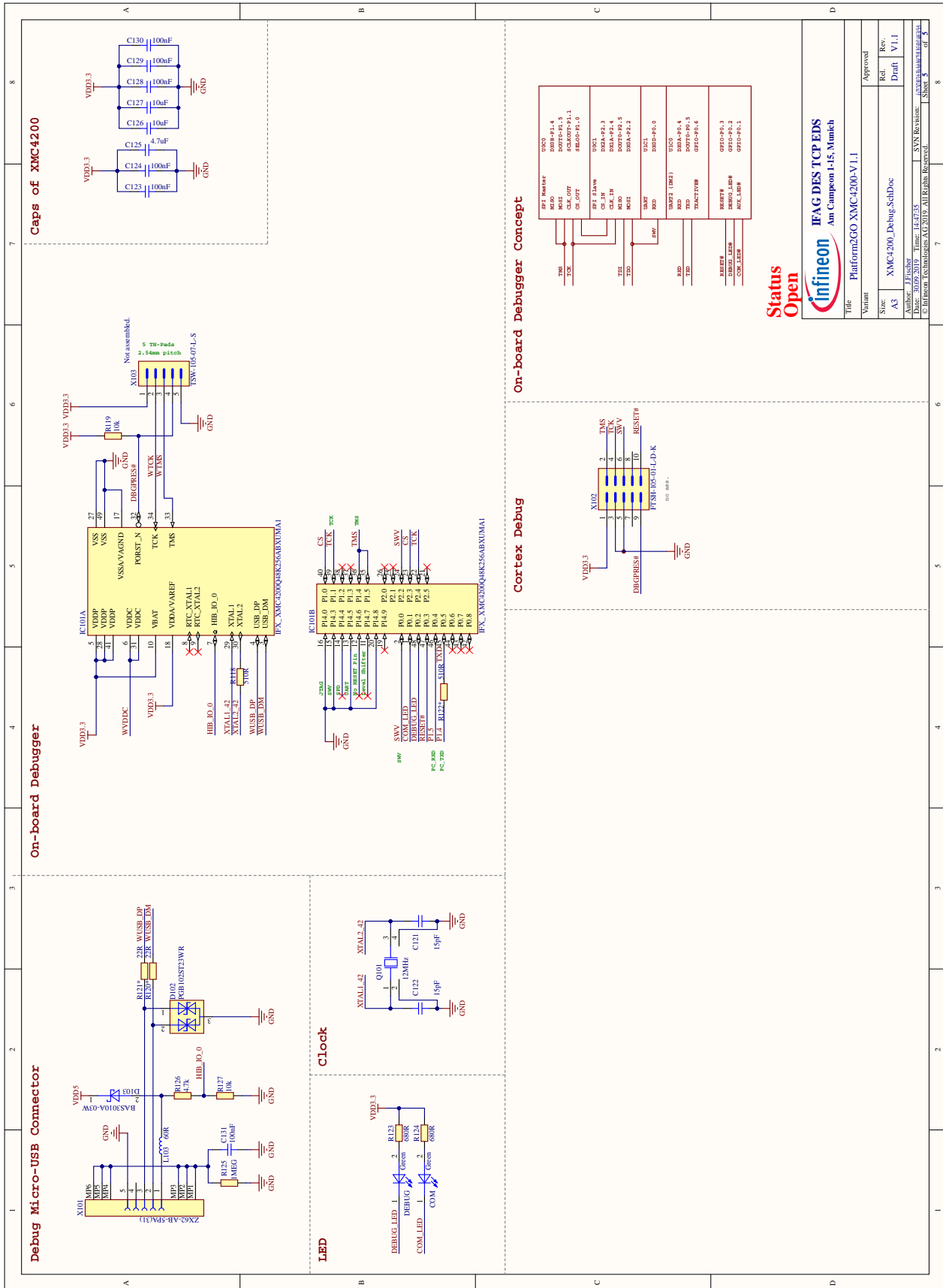
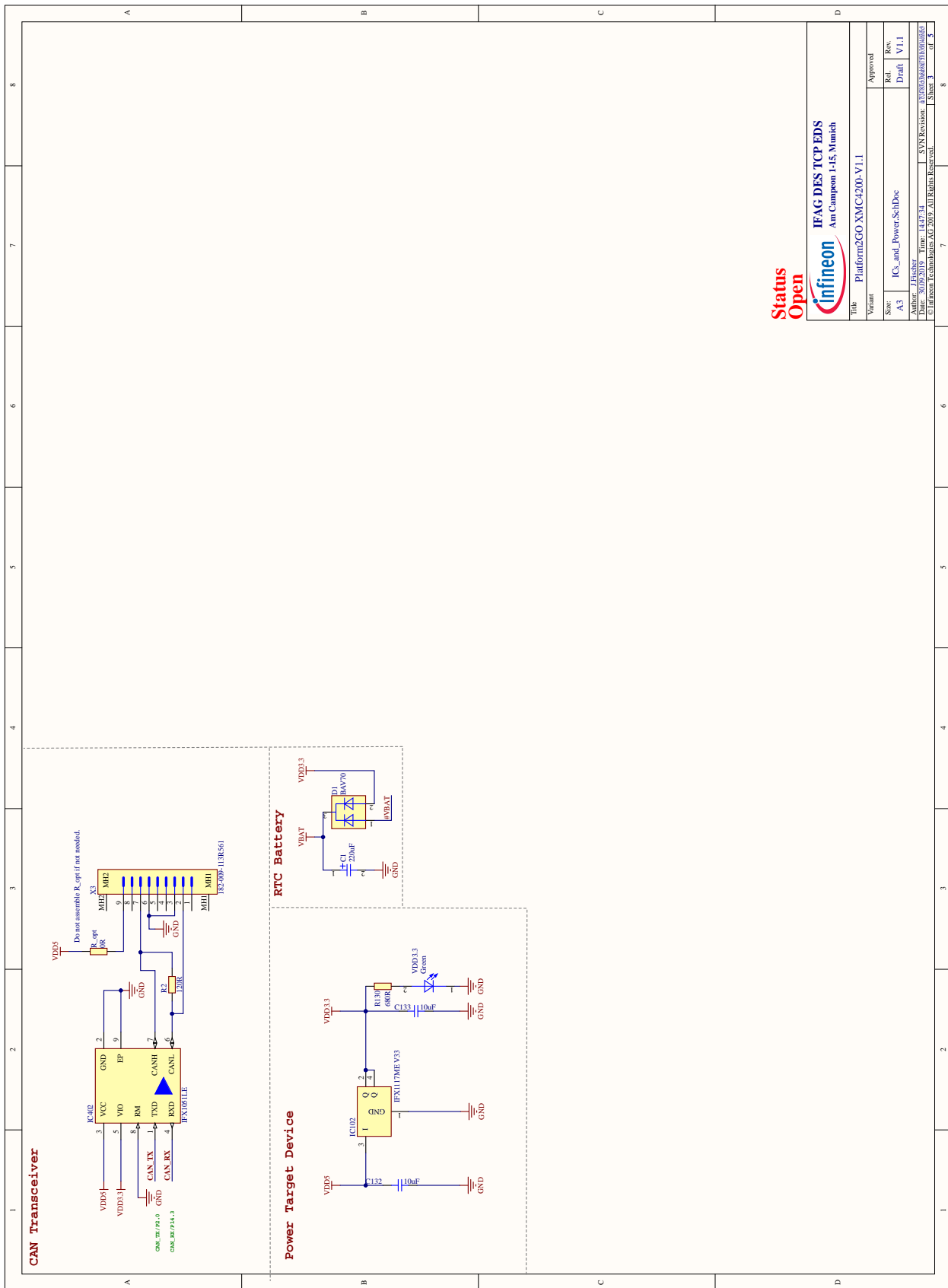

Figure 11 MXC_4200_Debug Schematic: OBD Probe



Status
Open

IFAG DES TCP EDS
Am Campeon I-15, Munich

Title	Platform2GO XMC4200-V1.1	Approved
Variant		
Size	ICs_and_Power-SchDoc	Rev
		Draft
		V1.1
Author	...	
Editor	...	
Checker	...	
Reviewer	...	
Release	...	
Sheet	3	of 5

Figure 13 ICs and Power Schematic: Can Transceiver, RTC Battery, Power

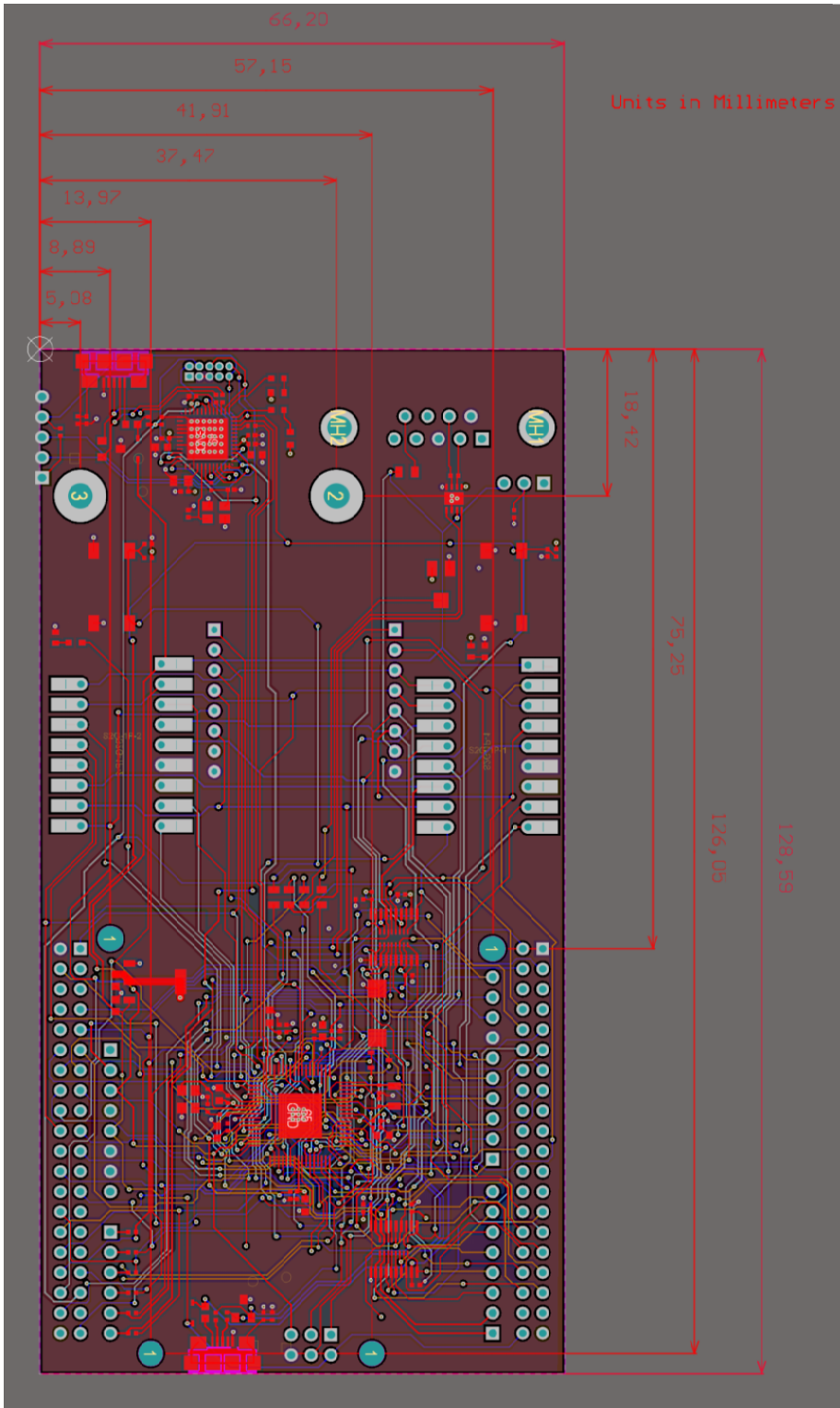

Figure 14 Geometry

3.2 List of Material

The list of material is valid for the Platform2Go XMC4200 3.3V/5V/Lite

Table 10 List of Material

Description	Designator	PackageReference	Value	Quantity	Not fitted in*
Micro Miniature Pushbutton Switch	BUTTON1 P1.15, RESET		FSM2JSMA	2	
Solid Tantalum Surface Mount Chip Capacitor	C1	CAPMP7343X310N-1	220uF	1	
Surface Mount Multilayer Ceramic Chip Capacitor	C100, C109, C110, C111, C112, C114, C115, C118, C304	0402/ 1005	100nF	9	
Surface Mount Multilayer Ceramic Chip Capacitor	C300, C301, C302, C303	0402/ 1005	100nF	3	A,C
Chip Monolithic Ceramic Capacitor	C101, C102, C103, C104, C126	CAPC1608X90N	10uF	5	
Multilayer Ceramic Chip Capacitor	C105, C106, C107, C108	0402/ 1005	100nF	4	
Chip Multilayer Ceramic Capacitor	C113, C127, C132, C133	0603 / 1608	10uF	4	
Chip Monolithic Ceramic Capacitor	C116, C117	CAPC1005X33N	15pF	2	
Chip Monolithic Ceramic Capacitor	C400, C401	CAPC1005X33N	15pF	2	C,D
Chip Monolithic Ceramic Capacitor	C120	CAPC1005X55N-0	10nF	1	
Chip Monolithic Ceramic Capacitor	C121, C122	CAPC1005X55N-0	15pF	2	
Chip Monolithic Ceramic Capacitor	C123, C124, C128, C129, C130, C131	CAPC1005X55N-0	100nF	6	
Chip Monolithic Ceramic Capacitor	C125	CAPC2013X95N	4.7uF	1	
Surface Mount LED, Green, 570nm	COM, DEBUG, VDD3.3	0603 / 1608	Green	3	
High-Speed Switching Diode	D1	SOT23	BAV70	1	
Bi-Directional Surface Mount	D100, D102	SOT-23	PGB102ST23WR	2	

Polymeric ESD Suppressor, 24V					
Medium Power AF Schottky Diode	D101, D103	SOD323	BAS3010A-03W	2	
Performance of the ARM Cortex-M4 Core with Powerful On-Chip Peripheral Subsystems, Temp Range(-40°C to 125Å°C)	IC101	PG-VQFN-48-53	XMC4200Q48K256	1	
Voltage Regulator, 3.3 V Output	IC102	PG-SOT223	IFX1117ME V33	1	
8-Bit Bidirectional Voltage-Level Translator for Open-Drain and Push-Pull Applications	IC300, IC301	TSSOP-20	TXS0108EPWR	2	A,C
Industrial High Speed CAN-FD Transceiver	IC402	PG-TSON-8-1	IFX1051LE	1	C,D
Through hole .025" SQ Post Header, 2.54mm pitch, 3 pins, vertical, Single Row	JP300		TSW-103-05-L-S	1	C,D
For Power Lines; For General	L100, L102, L103	SMD Chip	60R	3	
LED	LED1 P0.1	0603 / 1608	Red	1	
mikroBUS Host Socket	MIKROBUS	Two times 1x8 pins, 2.54 mm pitch, female		1	
SMD Crystal Unit for Automotive Application, 12.000MHz	Q100, Q101	SMD 3.2 x 2.5 x 0.6mm	12MHz	2	
SMD, 32.768kHz ±20PPM,12.5pF Crystal Unit	Q400	SMD 3.2 x 1.5 x 0.8 mm	32.77kHz	1	C,D
Standard Thick Film Chip Resistor	R2	0402 / 1005	120R	1	CD
Automotive Grade Thick Film Chip Resistor, General Purpose Chip Resistor	R3, R4, R5, R7	0805 / 2012	0R	4	

Production Data

Surface Mount Single Turn Trimmer, Model 23A - J Hook	R8 POTI P14.0	SMT	23AR10KLFTR / 10kOhm	1	
Standard Thick Film Chip Resistor	R100, R101, R102, R103, R104, R105	0402 / 1005	100R	6	
Standard Thick Film Chip Resistor	R106, R125	0402 / 1005	1MEG	2	
Standard Thick Film Chip Resistor	R107, R108, R120*, R121*	0402 / 1005	22R	4	
Standard Thick Film Chip Resistor, 0R/50V	R109	0402 / 1005	0R	1	
Standard Thick Film Chip Resistor, 0R/50V	R301, R303	0402 / 1005	0R	2	N
Standard Thick Film Chip Resistor	R111, R118, R122*	0402 / 1005	510R	3	
Standard Thick Film Chip Resistor	R112, R130	0603 / 1608	680R	2	
Standard Thick Film Chip Resistor	R114, R116, R119, R127	0402 / 1005	10k	4	
Standard Thick Film Chip Resistor	R300, R302	0402 / 1005	10k	2	A,C
Automotive Grade Thick Film Chip Resistor	R123, R124	0603 / 1608	680R	2	
Standard Thick Film Chip Resistor	R126	0402 / 1005	4.7k	1	
Standard Thick Film Chip Resistor	R_opt	0805 / 2012	0R	1	N
Chip Resistor Array, Temp Range (-55 to 125Å°C)	RA200, RA300		0R	2	B,D
Microcontroller Series for Industrial Appllication, Temp Range (-40° to 125°C)	U1	PG-TQFP-64-19	XMC4200-F64K256	1	
Shield2Go Connector	S2G-1P-1, S2G-1P-2		Two times 1x9 pins and 1x8 pins, 2.54mm pitch, female	1	N
2.54mm PC/104 Connector, Stackthrough	X1, X2		M20-6102045	2	N

Production Data

R/A - 0.318 - Male Economy D-SUB	X3		182-009-113R561	1	C,D
Micro-USB 2.0 Standard, Type AB, Bottom Mount, Shell SMT	X100, X101		ZX62-AB-5PA(31)	2	
THT Micro Header, 1.27mm pitch, 10 pin, vertical, double row, keying shroud , DAP	X102		FTSH-105-01-L-D-K	1	N
Through hole .025" SQ Post Header, 2.54mm pitch, 5 pin, vertical, single row	X103		TSW-105-07-L-S	1	N
Through hole .025" SQ Post Header, 2.54mm pitch, 6 pin, vertical, double row	X300		TSW-103-07-L-D	1	
Through hole .025" SQ Post Header, 2.54mm pitch, 6 pin, vertical, single row	X301		TSW-106-07-L-S	1	
Through hole .025" SQ Post Header, 2.54mm pitch, 8 pin, vertical, single row	X302		TSW-108-23-F-S	1	
Through hole .025" SQ Post Header, 2.54mm pitch, 8 pin, vertical, single row	X303		TSW-108-07-L-S	1	
Through hole .025" SQ Post Header, 2.54mm pitch, 10 pin, vertical, single row	X304		TSW-110-07-L-S	1	

***Agenda:**

- A: XMC4200 Platform2Go for 3.3V Shields
- B: XMC4200 Platform2Go for 5V Shields
- C: XMC4200 Platform2Go Lite for 3.3V Shields
- D: XMC4200 Platform2Go Lite for 5V Shields
- N: Not assembled in all Versions

www.infineon.com