



LED lighting

Semiconductors for power conversion and smart lighting

www.infineon.com/lighting





Contents

Introduction	4	LED strips and signage	30
LED drivers	6	Linear LED driver ICs	31
Mixed-signal PFC and flyback controllers	7	Very low-cost LED driver ICs	32
IRS2982S	7	BCR401W/BCR402W	32
IRS2505L	8	Low-voltage-drop LED driver ICs	33
ICE2PCS0XG/ICE3PCS0XG	9	BCR430U/BCR431U	33
SiC diodes for high-power applications	10	Robust LED driver ICs	34
Digital flyback controllers	11	BCR320U/BCR420U	34
XDPL8105	11	BCR401U/BCR402U/BCR405U	35
XDPL8210	12	LED driver ICs for 48 V supply	36
XDPL8218	13	BCR602	36
XDPL8220/XDPL8220e	14	Radar sensors for smart lighting	38
XDPL8221	15	Radar sensors for presence detection and more	39
PFC plus half-bridge resonant controllers	16	Our partners	40
ICL5102	16	Radar partner ecosystem at a glance including design house partners	42
ICL5102HV	17		
DC-DC buck converters and smart controllers	18		
ILD8150	18		
ILD6150	19		
BCR601	20		
IRS2982 for high-voltage buck	21		
CoolMOS™ – high-voltage MOSFETs	22		
950 V CoolMOS™ P7	23		
800 V CoolMOS™ P7	24		
700 V CoolMOS™ P7	25		
600 V CoolMOS™ P7	26		
OptiMOS™ 5 – medium-voltage MOSFETs	27		
150 V OptiMOS™ 5 for synchronous rectification	27		
NFC IC for configuration	28		
NLM0010/NLM0011	28		
0–10 V dimming interface IC	29		
CDM10V	29		

Get ready for the next big thing in LED lighting

LED lights have become part of our daily lives, making a significant contribution to global efforts to reduce our carbon footprint. Most installations fitted with either inefficient light sources like incandescent lamps or even more efficient sources like HID lamps designed for long hours of operation have already been replaced by LED lights. LED penetration has been particularly rapid across applications such as tunnel and subway lighting and outdoor lighting.

Looking ahead, the next steps will focus on:

- › High-power LED lighting, for instance in stadiums
- › Horticultural lighting to replace 1000 W HPS lamps
- › Office lighting to replace fluorescent lamps

Many may assume that these developments will mark the end of the LED innovation journey. Here at Infineon Technologies, however, we anticipate significant new momentum in the LED space – and we are set to help shape future developments.

All indicators show that current efforts are not sufficient to slow down global warming. Today, many LED installations are not equipped with any control technology. Many users are satisfied with the energy savings they have achieved thus far simply by converting their existing light sources to LEDs. Looking to the future, however, this is set to change – driven by direct or indirect regulatory requirements and the resulting increase in taxes on energy consumption and/or CO₂ emissions.



Hakan Yilmazer
Head of Application
Marketing for Lighting

Widespread implementation of presence detectors would be an extremely effective way to reduce energy consumption significantly. These sensors will have to meet more stringent demands than the current passive infrared sensors that can only detect very rough motion.

Another topic that is set to gain more attention is the efficiency and dimming quality of LED drivers. Today, most users are happy with an efficiency rate of 88 percent for power conversion. However, this figure could be easily pushed far above 90 percent by changing the topology for the power conversion.

Dimming is currently widely deployed in residential and hospitality lighting applications. Street lighting applications do not typically support dimming functionality. LED dimming has the potential not only to enable huge power savings compared with previous light sources, but also to extend the lifetime of the system.

Here at Infineon Technologies, we are passionate about developing these exciting applications in collaboration with our customers and partners. Our ambition is to offer tailored products and solutions to our customers that help them to address the key energy efficiency challenges facing society now and in the future.

We hope you enjoy reading our new LED lighting brochure.

Lighting system overview

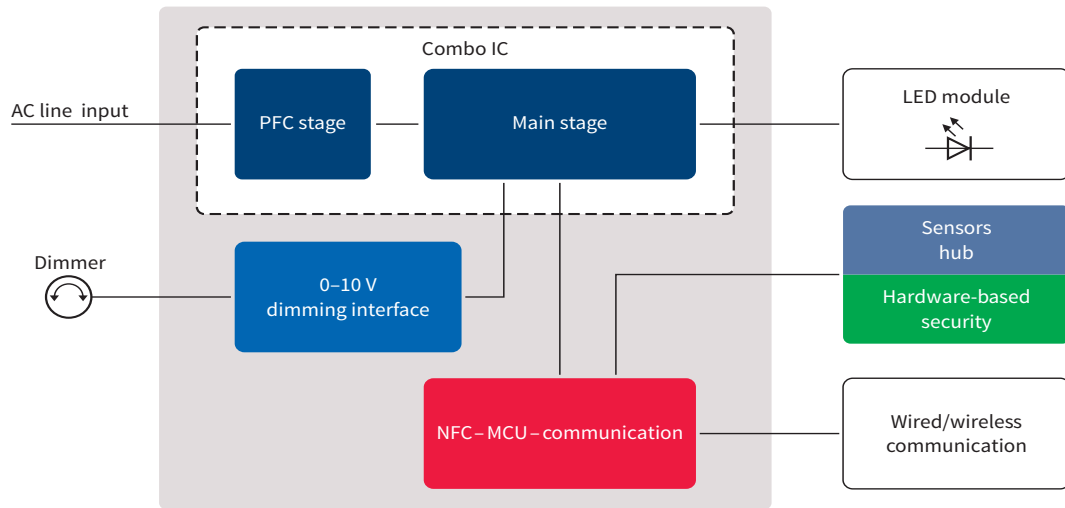



LED drivers

The type of LED drivers used in an LED lighting application has a significant impact on key system performance indicators such as:

- › Efficiency
- › Dimming capability
- › Power quality, i.e. PFC/THD
- › Light quality, i.e. ripple/flicker
- › Configurability of parameters, i.e. output current
- › Ability to support add-on features such as power monitoring
- › Product lifetime

System efficiency can be influenced by the choice of topology and the type of components used. A resonant topology, for instance, can increase LED driver efficiency by 4–5 percent. The right MOSFETs, a high-voltage start-up cell and synchronous rectification can also have a positive impact. Dimming down to 1 percent light output has become mainstream for indoor lighting.

Design strategies usually use analog dimming to a certain level and then switch to PWM dimming for lower levels. Many customers demand compliance with PFC and THD regulatory requirements at 50 percent dimming.

LED drivers based on a single-stage flyback topology usually have an output current ripple of ± 30 percent. Growing dissatisfaction with this ripple is fueling widespread adoption of two-stage topologies, i.e. single-stage PFC flyback combined with a secondary buck regulator.

To date, DIP switches have been typically deployed to configure the output current of LED drivers. The trend is now moving towards more elegant methods with LED driver manufacturers and lighting fixture makers opting for NFC technology, for example. Digital controllers with a digital interface such as UART enable designers to implement power monitoring at luminaire level.

www.infineon.com/leddrivers

Mixed-signal PFC and flyback controllers

IRS2982S – single-stage PFC/flyback controller for constant voltage output

Features

- > Integrated 600 V high-voltage start-up cell
- > Multi-mode operation, DCM operation at light loads (minimum off-time)
- > Overvoltage protection
- > Burst-mode operation at very light loads

Benefits

- > Integrated start-up cell enables very high efficiency for wide-range input designs combined with fast time-to-light
- > Optimal efficiency, power factor and THD can be achieved by most suited mode. In addition, DCM eases compliance with EMI at low load condition by limiting the switching frequency

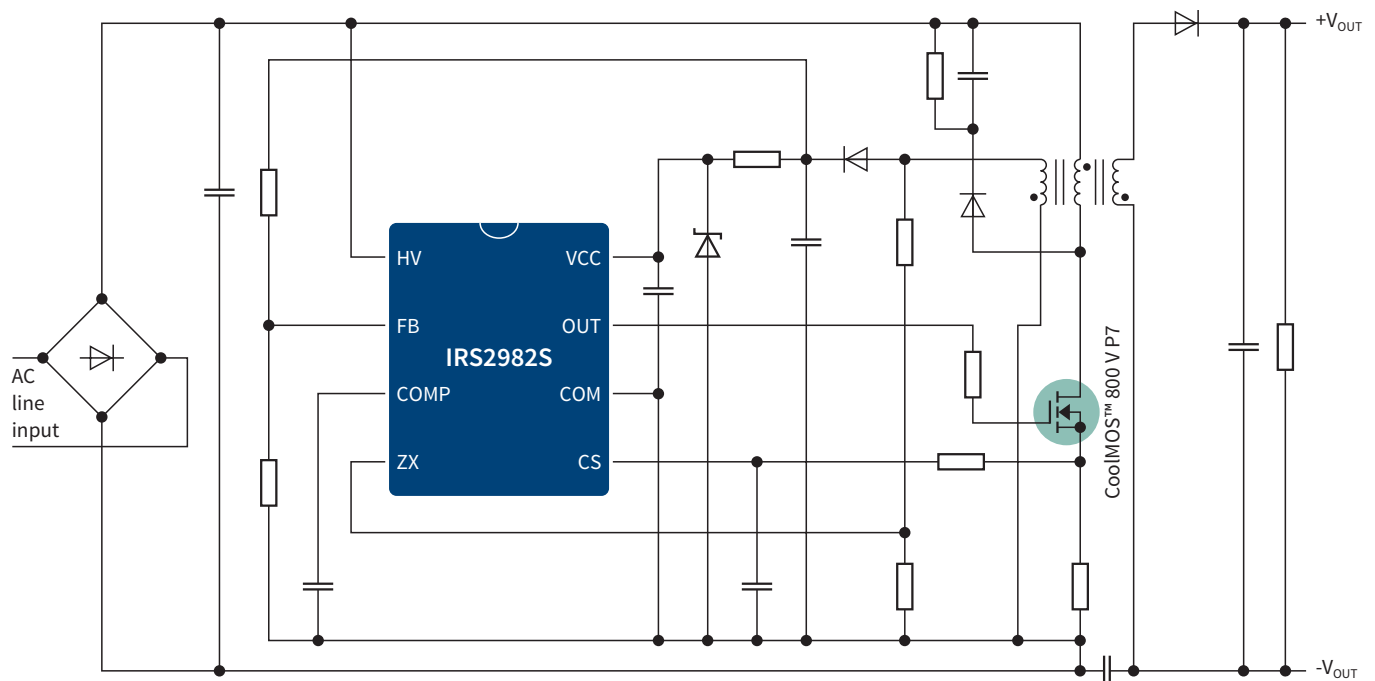

Application note

Name	Description
ANEVAL_201602_PL16_017	55 W flyback converter design using the IRS2982S controller IRLXLED04

Evaluation board

Name	Products	Description
IRLXLED04 50W Flyback eval board	IRS2982S, CoolMOS™ 800 V CE, CoolMOS™ 800 V P7	50 W flyback converter design using the IRS2982S controller

Mixed-signal PFC and flyback controllers

IRS2505L – low-cost PFC controller

Features

- > SOT23-5 package
- > High power factor and ultra-low THD over a wide input range
- > Zero crossing sensed via the gate drive
- > PFC inductor auxiliary winding not necessary
- > Critical Conduction Model (CrCM) operation – low switching losses

Benefits

- > 70% smaller than a conventional SO8 package
- > Gate driver optimized to eliminate switch-off diode
- > Cycle-by-cycle overcurrent protection
- > Micro power start-up – very low start-up losses

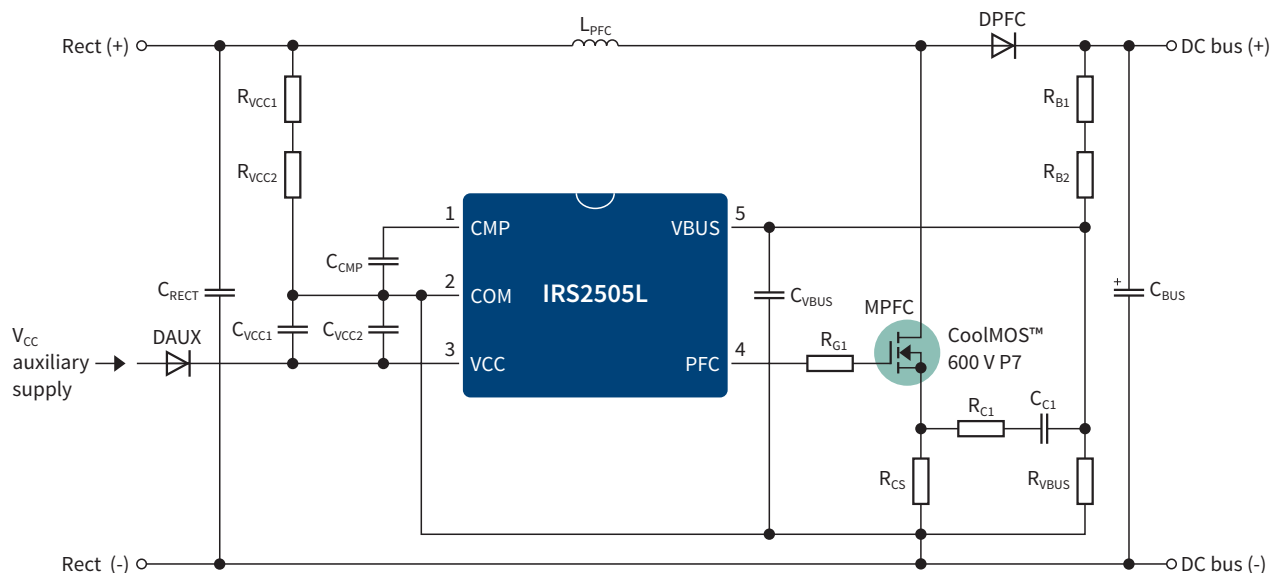

Application note

Name	Description
UG_201705_PL16_05	Non-isolated two-stage boost PFC plus current-regulated buck LED driver IRXLED09

Evaluation board

Name	Products	Description
IRXLED09	IRS2505, CoolMOS™ 600 V P7	Non-isolated two-stage boost PFC plus current-regulated buck LED driver IRXLED09

ICE2PCS0xG/ICE3PCS0xG – CCM PFC controller

For power ranges above 300 W, CCM PFC mode offers benefits in terms of efficiency compared to DCM PFC mode.

Features

- › Trimmed internal reference voltage ($2.5\text{ V} \pm 1.2\%$)
- › Low peak current limit threshold
- › Bulk “voltage good” signal for inrush relay control or PWM IC enabling
- › Integrated digital voltage loop compensation
- › Programmable switching (20-100 kHz)
- › External synchronization (50 ~ 100 kHz)
- › Direct sensing, input brown-out detection with hysteresis

Benefits

- › Enhanced dynamic response
- › Ease of use with few external components
- › External current compensation for greater user flexibility

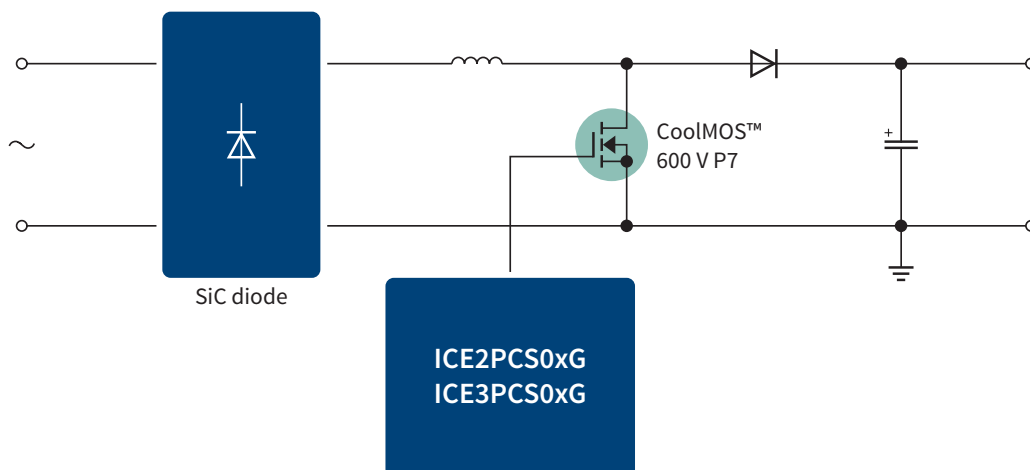

Application note

Name	Description
EVALPFC-300W-ICE3PCS01G	Programmable FF CCM PFC controller ICE2PCS01 for 300 W 393V PFC evaluation board with 85 ~ 265 V AC universal input

Evaluation board

Name	Products	Description
EVALPFC2-ICE2PCS01	CCM PFC controller, SiC diode, CoolMOS™	Programmable FF CCM PFC controller ICE2PCS01 for 300 W 393V PFC evaluation board with 85 ~ 265 V AC universal input

SiC diodes for high-power applications

SiC diodes enable highest efficiency in combination with CCM PFC Controllers in high power LED applications

Features

- › No reverse recovery charge
- › Purely capacitive switching
- › High operating temperature (T_j , max 175 °C)

Benefits

- › System efficiency improvement compared to Si diodes
- › Reduced cooling requirements
- › Enabling higher frequency/increased power density
- › Higher system reliability
- › Reduced EMI

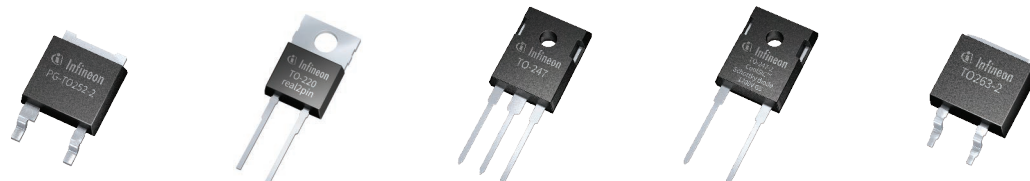

Continuous forward current, I_F [A]	TO-252 (DPAK real 2-leg)	TO-220 (real 2-leg)	TO-247-3	TO-247-2	D ² PAK-2
2	IDM02G120C5	IDH02G120C5			IDK02G120C5
5	IDM05G120C5	IDH05G120C5			IDK05G120C5
8	IDM08G120C5	IDH08G120C5			IDK08G120C5
10	IDM10G120C5	IDH10G120C5	IDW10G120C5B	IDWD10G120C5	IDK10G120C5
15–16		IDH16G120C5	IDW15G120C5B	IDWD15G120C5	IDK16G120C5
20		IDH20G120C5	IDW20G120C5B	IDWD20G120C5	IDK20G120C5
30			IDW30G120C5B	IDWD30G120C5	
40			IDW40G120C5B	IDWD40G120C5	

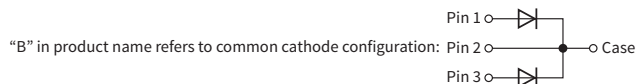

Digital flyback controllers

XDPL8105 – PFC/flyback controller for 0–10 V dimming

XDPL8105 is a primary-controlled high-performance single-stage PFC/flyback controller with constant current output.

Features

- > Multi-mode operation, quasi-resonant, discontinuous conduction mode (DCM)
- > Active burst mode (ABM)
- > Integrated 600 V start-up cell
- > Configurable parameters
- > Supports fully isolated 0 – 10 V dimming

Benefits

- > Optimal efficiency, power factor and THD can be achieved by most suited mode. In addition, DCM eases compliance with EMI at low load condition by limiting the switching frequency
- > ABM enables low-level analog dimming
- > Integrated start-up cell enables very high efficiency for wide-range input designs combined with fast time-to-light
- > Configurability of parameters like output current, protection modes and dimming curves enables last-minute adjustments, reducing stockkeeping

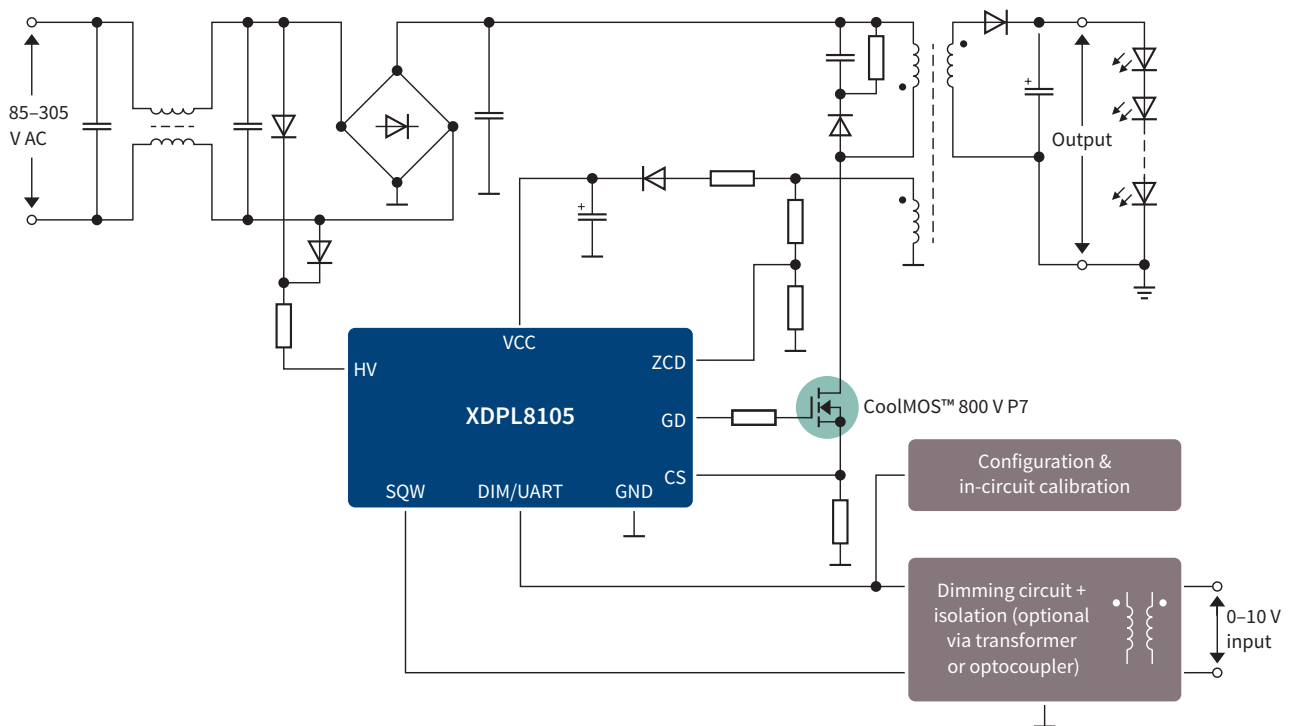

Application note

Name	Description
AN_1904_PL21_1905_103930	40 W demoboard with isolated 0–10 V dimming interface
System Simulation & Design Creation Tool	Transformer, BOM and IC parameters

Evaluation board

Name	Products	Description	Order number
REF-xdpl8105-cdm10v	XDPL8105, 800 V CoolMOS™	Reference board for XDPL8105 with dimming	SP001649474

Digital flyback controllers

XDPL8210 – multi-mode PFC/flyback controller for 0–10 V dimming

XDPL8210 is a primary-controlled single-stage PFC/flyback controller with constant current output that supports 1% dimming.

Features

- > All features included in XDPL8105
- > 1% dimming
- > Supports 0-10 V dim-to-off powering the dimmer
- > Limited Power (LP) mode
- > PWM dimming input pin
- > Enables BOM savings for the dimming circuit

Benefits

- > All benefits included in XDPL8105
- > Well suited for indoor lighting application where 1% dimming is required
- > Cost savings for an additional auxiliary power supply for the 0-10 V dimmer
- > Well suited for outdoor lighting in cold areas since LP mode enables start-up of LEDs even when their forward voltage is above the nominal output voltage

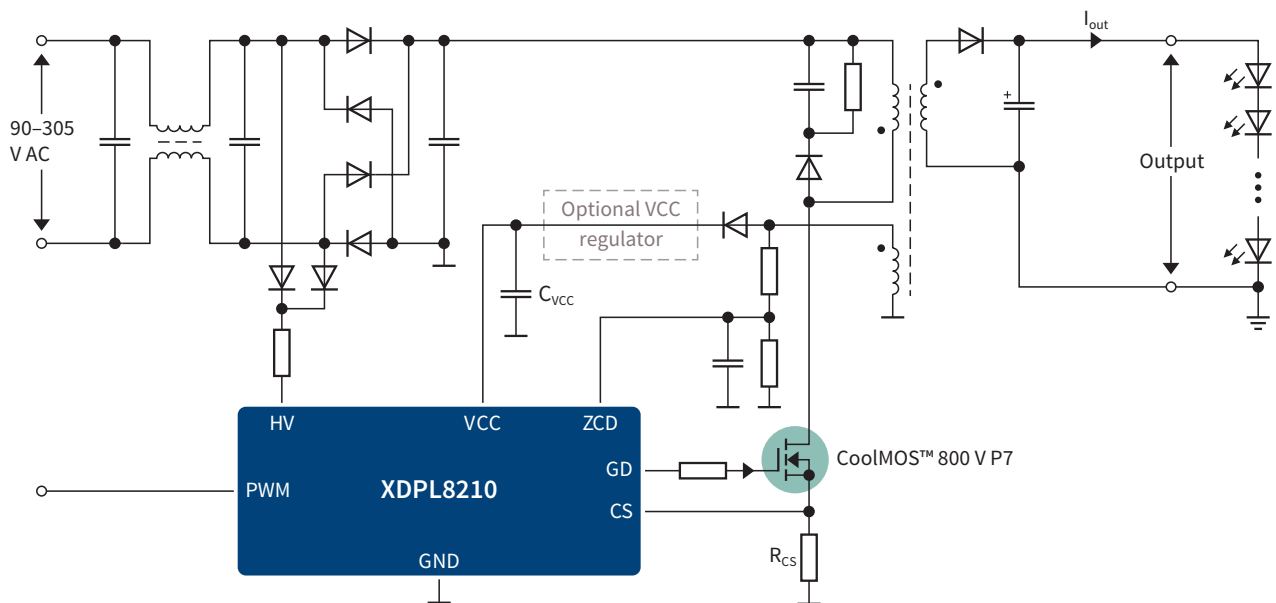

Application note

Name	Description
ER_1902_PL21_1903_042903	XDPL8210 CDM10VD 35 W reference design with IPN80R900P7 – LED driver with isolated 0 to 10 V dimming and dim-to-off operation

Evaluation board

Name	Products	Description	Order number
REF-XDPL8210-U35W	XDPL8210, 800 V CoolMOS™	XDPL8210 35 W constant current reference board with 0-10 V dimming interface	SP001886070

XDPL8218 – PFC/flyback controller with very low stand-by power

XDPL8218 is a primary-controlled single-stage PFC/flyback controller with constant voltage output with very low stand-by power enabling smart lighting applications.

Features

- › Secondary-Side-Regulated (SSR)
Constant Voltage (CV) output
- › Enhanced power factor correction
- › Depending on load condition, either quasi-resonant, discontinuous conduction mode or active burst mode (ABM)
- › Integrated 600 V start-up cell

Benefits

- › Supporting wide load range and fast and stable reaction to dynamic load changes
- › PFC > 0.9 can be achieved at 33% load at most severe condition (277 V input at 60 Hz)
- › Optimal efficiency, power factor and THD can be achieved by most suited mode. In addition, DCM eases compliance with EMI at low load condition
- › Very low stand-by power < 100 mW can be achieved
- › Integrated start-up cell enables very high efficiency

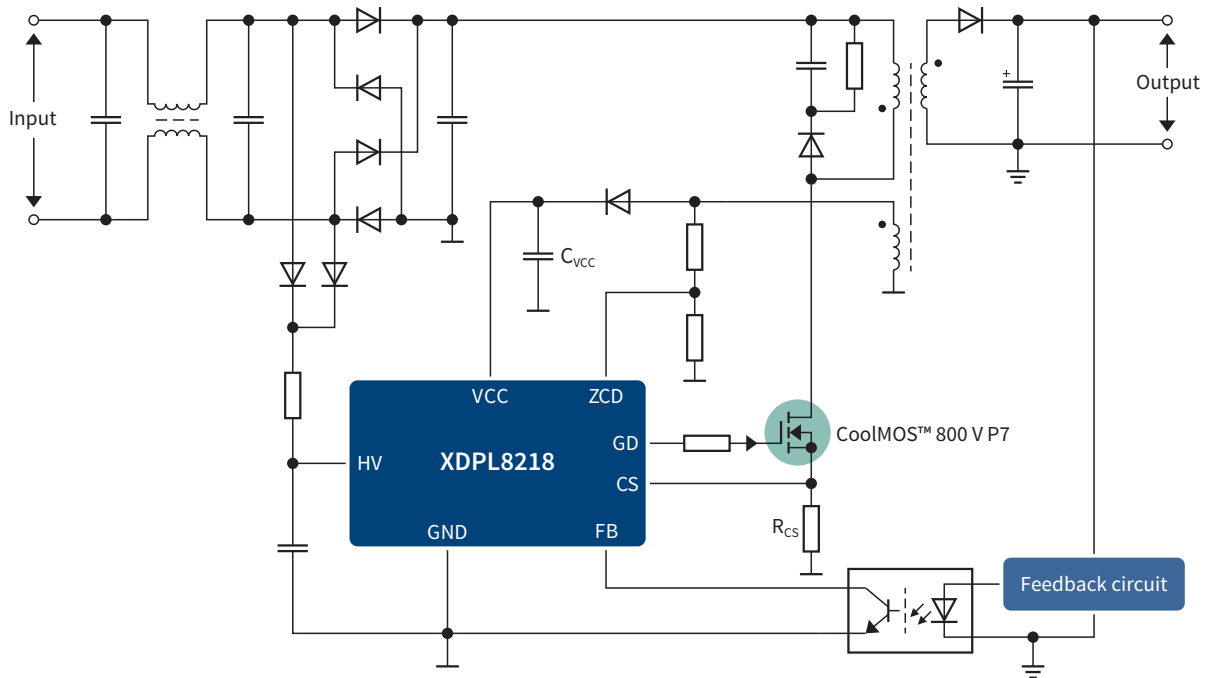

Application note

Name	Description
DG_1711_PL21_1802_031149	XDPL8218 design guide – high-power-factor flyback converter with constant voltage output

Evaluation board

Name	Products	Description	Order number
REF-XDPL8218-U40W	XDPL8218, 800 V CoolMOS™	Efficient 40 W reference circuit design for XDPL8218 with high power factor and low THD. It is built for universal input voltage 100–277 V AC or 127–430 V DC	SP001710980

Digital flyback controllers

XDPL8220/XDPL8220E – two-stage configurable PFC plus flyback controller

XDPL8220 is a primary-controlled two-stage PFC plus flyback controller that includes various add-on features.

Features

- > Two-stage Power Factor Correction (PFC) and flyback controller
- > Primary-Side-Regulated (PSR) multi-mode control: Constant Current (CC), Constant Voltage (CV) and Limited Power (LP)
- > Pulse Width Modulation (PWM) dimming control
- > Total harmonic distortion optimization (QR compensation)

Benefits

- > Enable advanced dual-stage LED driver for both indoor and outdoor applications
- > Maximize flexibility for global platform designs
- > Reduce product variants and inventory management complexity
- > 10% dimming and dim-to-off
- > Further improved THD

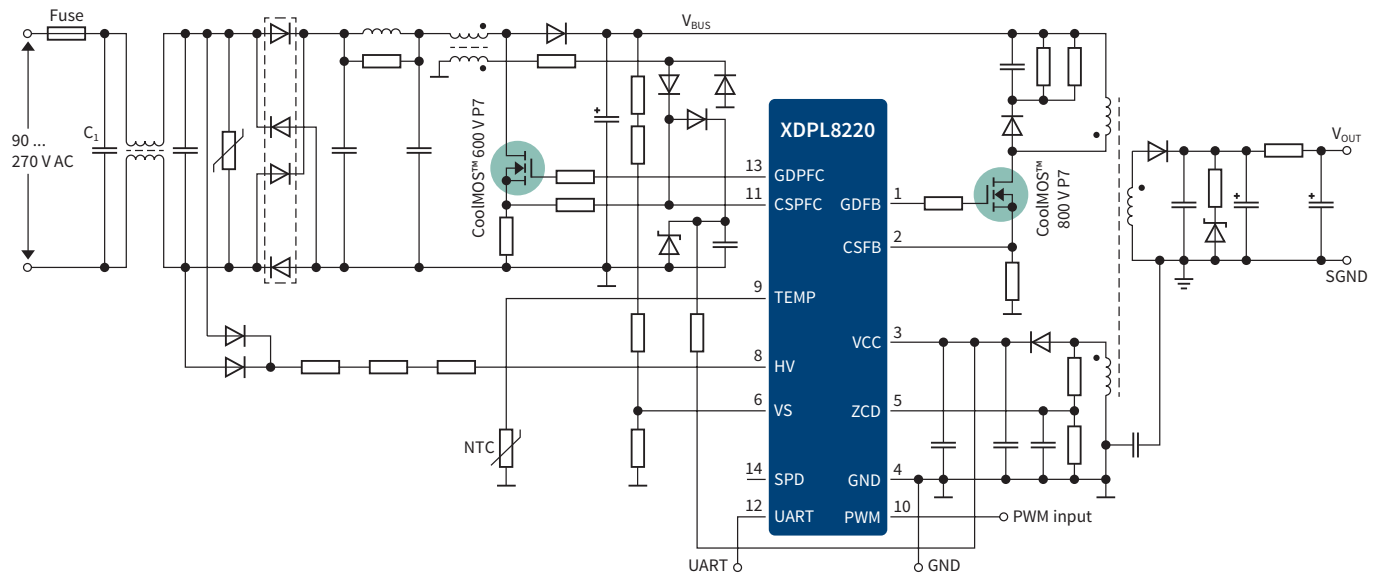

Application note

Name	Description
AN_201607_PL21_1	XDPL8220 – digital PFC + flyback combo controller IC – design a high-performance dual-stage (PFC + flyback) AC/DC-DC converter for LED lighting based on the digital controller XDPL8220

Evaluation board

Name	Products	Description	Order number
REF-XDPL8220-U30W	XDPL8220, 600 V & 800 V CoolMOS™	Efficient and flicker-free reference circuit design for XDPL8220 with high power factor and low THD. It is built for universal input voltage (100–277 V AC) and for 30 W output power. It implements a dual-stage PFC, flyback topology.	SP0016-30060
REF-XDPL8220-U50W	XDPL8220, 600 V & 800 V CoolMOS™	Efficient and flicker-free reference circuit design with high power factor and low THD, universal input voltage for 50 W output power.	SP0016-30066
REF-XDPL8220-U100W	XDPL8220, 600 V & 800 V CoolMOS™	Efficient and flicker-free 100 W reference circuit design with high power factor and low THD, universal input voltage.	SP001630068

XDPL8221 – two-stage intelligent & configurable PFC plus flyback controller

XDPL8221 includes all features of 8220E and in addition features enabled by UART communication including dimming via UART and reading out of data like fault condition and power monitoring.

Features

- > Two-stage Power Factor Correction (PFC) and flyback controller
- > Primary-Side-Regulated (PSR) multi-mode control: Constant Current (CC), Constant Voltage (CV) and Limited Power (LP)
- > Extra UART dimming control
- > Control driver output and reading operating status through UART

Benefits

- > Best choice for advanced LED driver, smart lighting and IoT applications
- > Less than 1% flicker-free dimming
- > Maximize flexibility of system design thanks to window programmability
- > Long lifetime of service

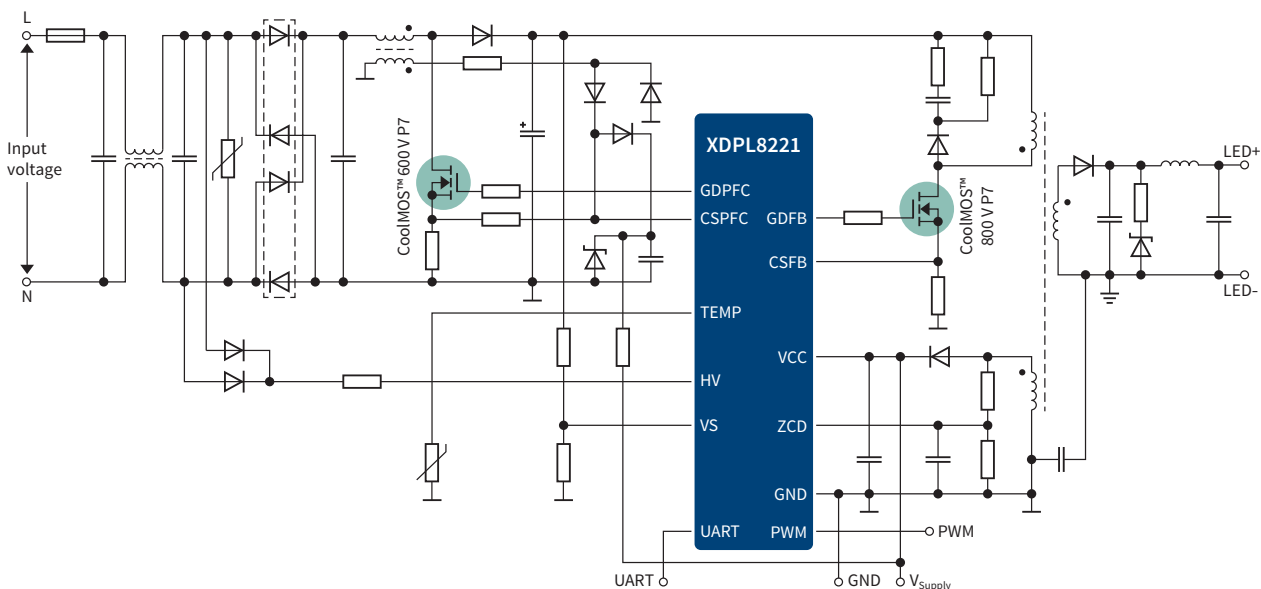

Application note

Name	Description
DG_1711_PL21_1712_143020	XDPL8221 digital PFC + flyback controller IC – a high-performance dual-stage digital PFC + flyback AC-DC converter using the XDPL8221 controller for LED lighting applications
AN_1901_PL21_1902_043849	XDPL8221 limited power mode – the Limited Power (LP) mode of XDPL8221, and the dimming operation in LP mode
AN_1901_PL21_1902_071326	XDPL8221 CSV file parameter description for 50 W reference design – the parameters defined in the CSV file for the XDPL8221 digital controller

Evaluation board

Name	Products	Description	Order number
REF-XDPL8221-U50W	XDPL8221, 600 V & 800 V CoolMOS™	Efficient and flicker-free reference circuit design for XDPL8221 with high power factor and low THD. It is built for universal input voltage (100–277 V AC) and for 50 W output power	SP0031-27452
REF-XDPL8221-U100W	XDPL8221, 600 V & 800 V CoolMOS™	Efficient and flicker-free reference circuit design for XDPL8221 with high power factor and low THD. It is built for universal input voltage (100–277 V AC) and for 100 W output power	SP0017-10982

www.infineon.com/xdpl8221

PFC plus half-bridge resonant controllers

ICL5102

ICL5102 is a PFC plus half-bridge resonant controller that has excellent PFC and THD performance combined with high-frequency operation in order to minimize the bill of materials.

Features

- › Integrated two-stage combination controller
- › Supports universal AC nominal input voltage (90 to 305 V_{RMS})
- › Excellent system efficiency of up to 94%
- › THD optimization ensures low harmonic distortion (Total Harmonic Distortion (THD) < 5%) down to 30% nominal load
- › Maximum 500 kHz HB switching frequency and soft-start frequency up to 1.3 MHz

Benefits

- › Simplify system design for PFC plus LLC/LCC topologies with less component counts and optimized bill of materials (BOM) and form factor
- › Address global platforms with one IC
- › Strong efficiency, PF and THD performance packaged in a combo-IC
- › Integrated coreless transformer offers robustness against dV/dt, negative voltage
- › Minimize form factors due to high switching frequency capability

ICL5102 – typical application with PFC + LCC topology

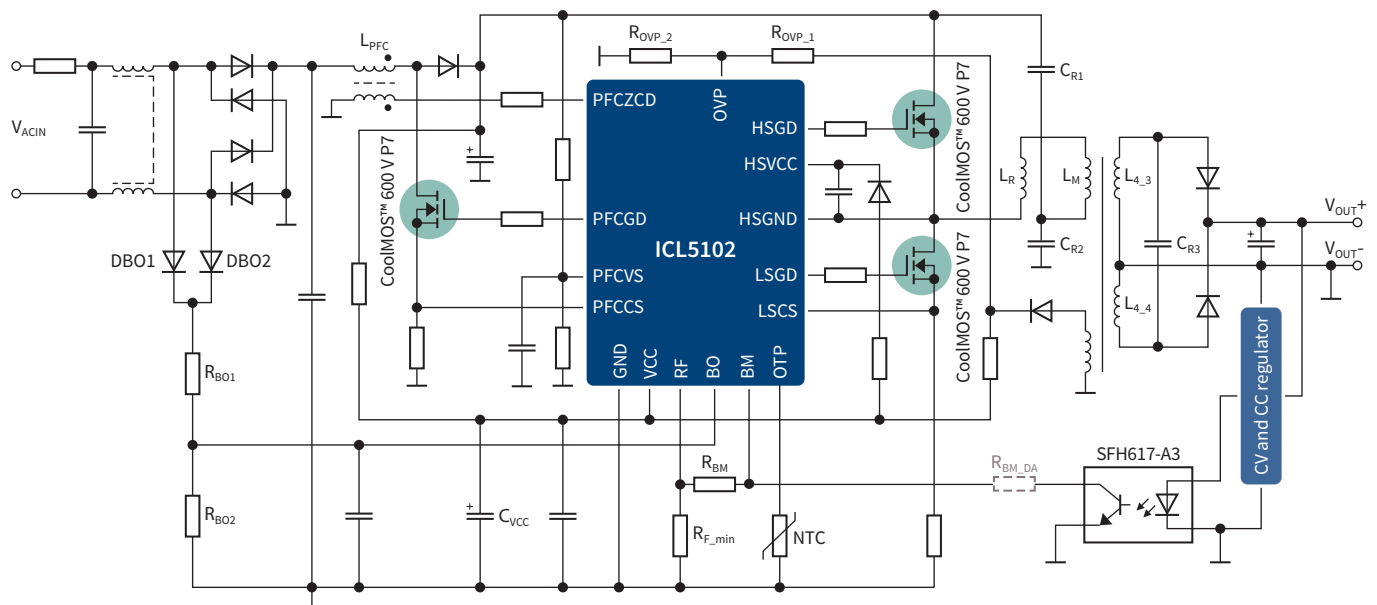

Application note

Name	Description
Engineering report for 130W with ICL5102	130 W dimmable constant current LED driver using PFC and LLC

Evaluation board

Name	Products	Description	Order number
REF-ICL5102-U130W-CC	ICL5102, 600 V CoolMOS™	PFC/LLC evaluation board 130 W LED driver	SP0016-67160
REF-ICL5102-320W-LLC-CV	ICL5102, 600 V CoolMOS™	PFC/LLC evaluation board 320 W LED driver	SP0053-98331

ICL5102HV

ICL5102HV is a PFC plus resonant combo controller that has excellent PFC and THD performance combined with high-frequency operation in order to minimize the bill of materials.

Features

- > All features mentioned in ICL5102
- > High Voltage (HV) version supports (90 to 480 V_{RMS})

Benefits

- > All benefits mentioned in ICL5102
- > ICL5102HV can be used in street lighting, horticultural lighting and industrial lighting where 480 V AC is used as input voltage

ICL5102HV – typical application with PFC + LLC topology

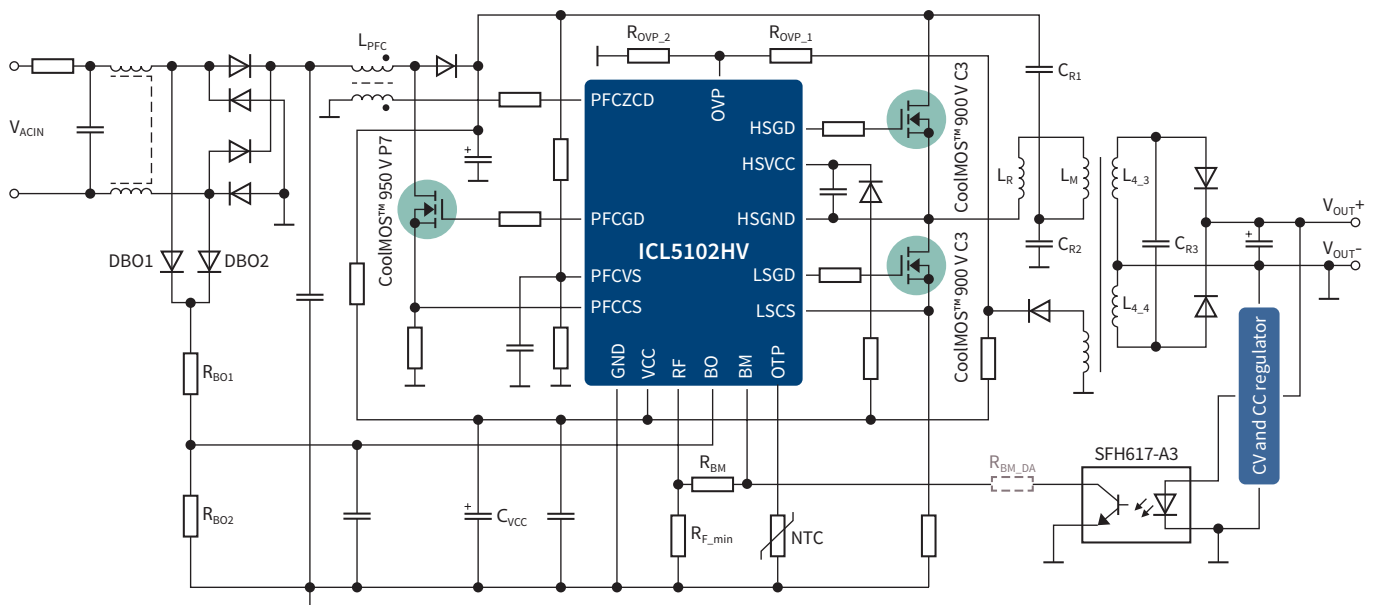

Application note

Name	Description
Reference design for 150W with ICL5102HV	150 W LCC LED driver demonstration board with ICL5102HV

Evaluation board

Name	Products	Description	Order number
REF-ICL5102HV-U150W	ICL5102HV, 900 V & 950 V CoolMOS™	ICL5102HV 150 W driver board	SP0053-46355

DC-DC buck converters and smart linear controller

ILD8150 – 80 V DC-DC buck LED driver IC

ILD8150 is a DC-DC LED driver IC with 80 V breakdown voltage with an integrated MOSFET.

Features

- > Input voltage up to 80 V
- > Integrated MOSFET for up to 1.5 A output current
- > Hybrid dimming down to 0.5%
- > Current precision $\pm 3\%$
- > Soft-start, UVLO, current limitation, low-power shutdown

Benefits

- > High safety margin for voltage transients and spikes
- > Optimal BOM due to integrated MOSFET
- > Deep dimming performance without flicker and noise via innovative one-pin hybrid method
- > High current precision leads to high light quality
- > Fast, stable and efficient regulation

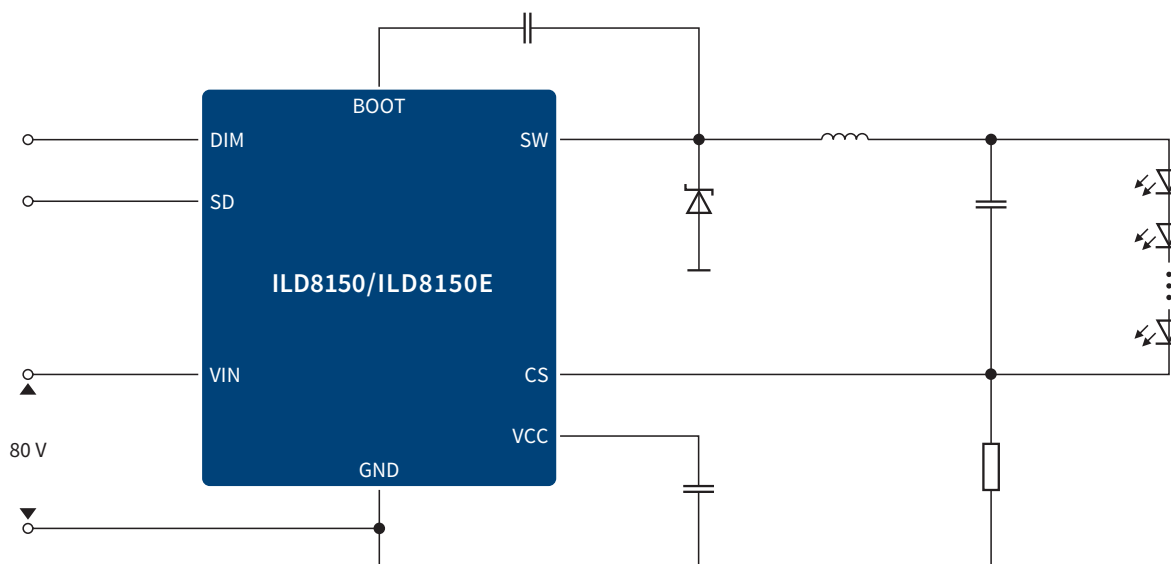

Application note

Name	Description
REF_ILD8150_DC_1.5A high frequency operation	High-frequency operation with ILD8150
Reference board REF_ILD8150_DC_1.5A LED driver IC ILD8150 80V	Operation, design guide and performance

Evaluation board

Name	Products	Description	Order number
REF_ILD8150_DC_1.5A	ILD8150E	Reference design board 1.5 A with coil inductor	SP002798058
REF_ILD8150_DC_1.5A_SMD	ILD8150E	Reference design board 1 A with SMD inductor	SP005351260

ILD6150 – 60 V DC-DC buck LED driver IC

ILD6150 is a DC-DC LED driver IC with 60 V break-down voltage with an integrated MOSFET.

Features

- > Input voltage up to 60 V
- > Integrated MOSFET for up to 1.5 A output current
- > PWM or analog input for dimming
- > Thermally enhanced DSO-8 exposed pad package

Benefits

- > Well suited for LED drivers with SELV
- > Optimal BOM due to integrated MOSFET
- > Flexibility for dimming input
- > Thermally robust product

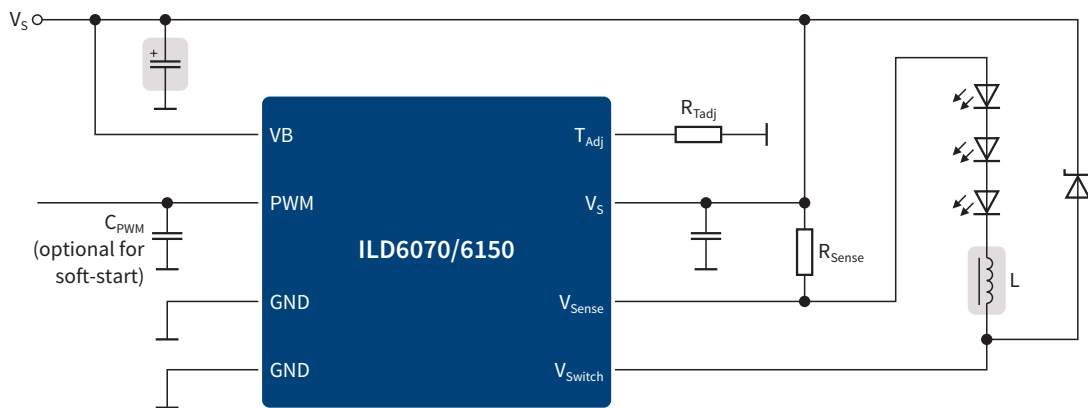

Application note

Name	Description
Application note AN-EVAL-ILD6070	60 V/0.7 A highly efficient step-down LED driver with adjustable thermal protection
Application note AN-EVAL-ILD6150	60 V/1.5 A highly efficient step-down LED driver with adjustable thermal protection

Evaluation board

Name	Products	Description
Evaluation board EVALLED-ILD6070	ILD6070	ILD6070 60 V/0.7 A highly efficient step-down LED driver with adjustable thermal protection
Evaluation board EVALLED-ILD6150	ILD6150	ILD6150 60 V/1.5 A highly efficient step-down LED driver with adjustable thermal protection

www.infineon.com/ild6150
www.infineon.com/ild6070

DC-DC buck converters and smart linear controller

BCR601 – 60 V linear LED controller with active headroom control

BCR601 is a linear controller that enables high efficiency at low cost as a second-stage LED controller to replace DC-DC buck converters especially in low- to mid-power LED drivers.

Features

- > Input voltage up to 60 V
- > Voltage feedback to primary side
- > Can be operated with either BJT or N-channel MOSFET
- > Analog dimming down to 3%
- > Current precision $\pm 3\%$
- > OTP, OVP, hot-plug protection

Benefits

- > Well suited for LED drivers with SELV
- > Reducing voltage overhead and power loss in transistor for better system efficiency
- > Cost and performance can be optimized by selection of BJT or N-channel MOSFET
- > High light quality without flicker
- > Safe operation

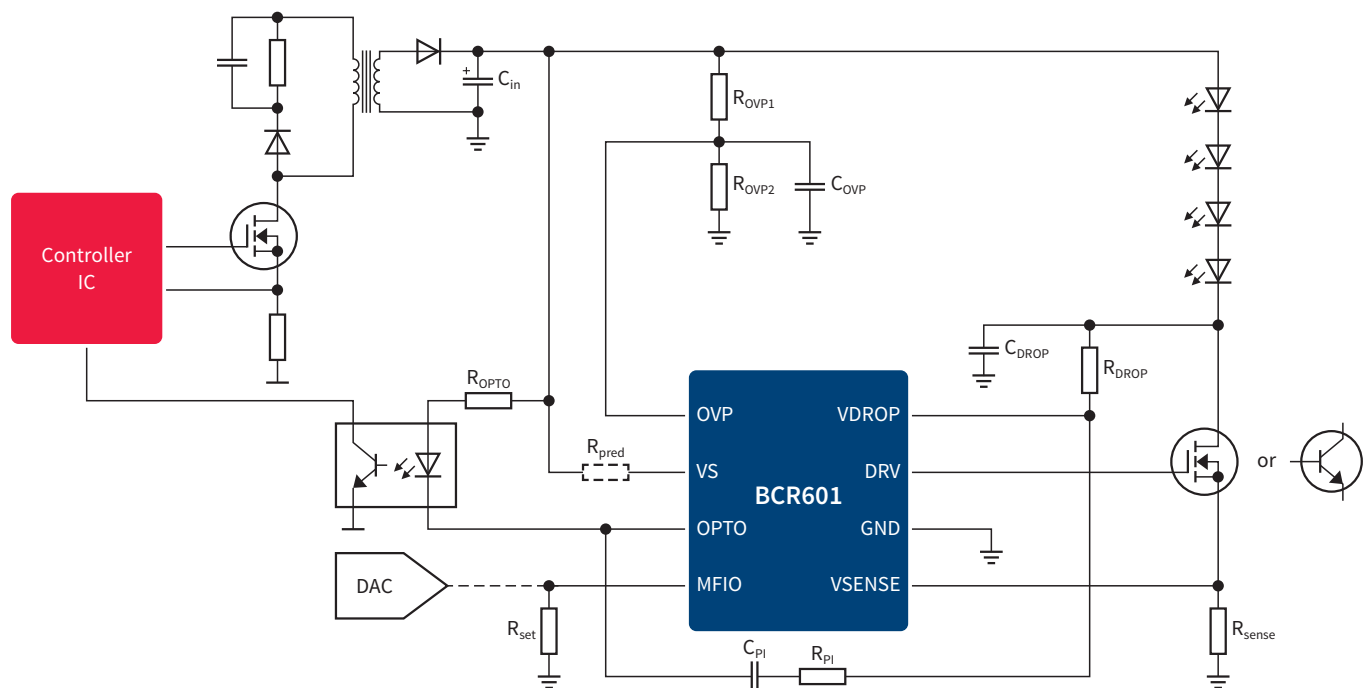

Application note

Name	Description
Design guide lighting ICs linear LED controller 60V BCR601	Design guide for a linear controller IC with feedback loop to primary side
Engineering report demoboard DEMO_BCR601_60V_IVCTRL	Engineering report for 60 V, 500 mA linear LED controller demonstration board

Evaluation board

Name	Products	Description	Order number
DEMO_BCR601_60V_IVCTRL	BCR601, BSP716N	This board is intended for the design evaluation of very cost-efficient, highly reliable, power-efficient LED drivers with linear LED driver IC BCR601	SP002798056

IRS2982 – universal controller for high voltage buck

IRS2982 is a multi-mode LED driver IC that can be used for the flyback stage mainly for constant voltage output as well as for the buck stage of non-isolated PFC boost followed by a high-voltage buck.

Features

- > Integrated 600 V high-voltage start-up cell
- > Multi-mode operation, DCM operation at light loads (minimum off-time)
- > Overvoltage protection
- > Burst-mode operation at very light loads

Benefits

- > Integrated start-up cell enables very high efficiency for wide-range input designs combined with fast time-to-light
- > Optimal efficiency, power factor and THD can be achieved by most suited mode. In addition, DCM eases compliance with EMI at low load condition by limiting the switching frequency

Second-stage buck convertor using IRS2982S

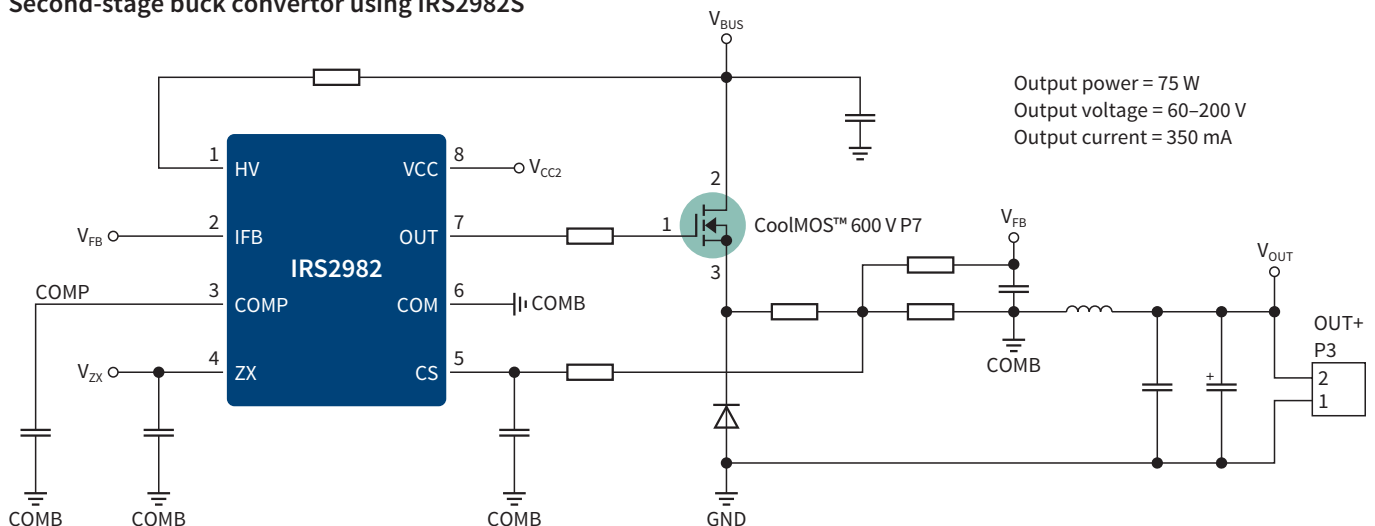

Supply for IRS2982 IC and optocoupler

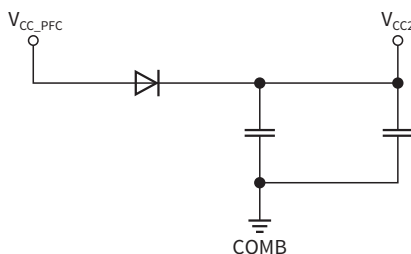

ZX detection

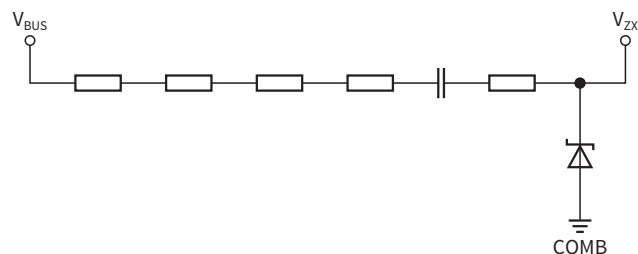

Application note

Name	Description
AN_1808_PL16_1809_234920	Non-isolated two-stage boost PFC plus current-regulated buck LED driver IRXLED10

Evaluation board

Name	Products
IRXLED10	IRS2505, IRS2982, 600 V CoolMOS™

www.infineon.com/irs2982s

CoolMOS™ – high-voltage MOSFETs

Trusted leader in high-voltage MOSFETs

CoolMOS™ is an extremely well-established technology in LED driver applications. The main reasons why LED driver customers choose CoolMOS™ include:

- > Proven quality and reliability
- > High efficiency
- > High-volume supply capability
- > Continuous portfolio expansion

For new designs, many LED driver makers are opting for the newest generation of CoolMOS™, namely the P7 family. Highlights of this latest generation include the best price/performance ratio and highly granular $R_{DS(on)}$ classes combined with diverse packages.

The SOT223 package, footprint-compatible with standard DPAK packages, has been a great success story in the lighting industry.

Another product family that has seen very high traction among lighting customers is the 950 V P7 family. Optimized for flyback topologies, where breakdown voltages above 800 V are required, 950 V P7 devices are emerging as the solution of choice among our customers.

Our 600 V P7 portfolio is designed for high efficiency across all higher-power applications with an $R_{DS(on)}$ of up to 600 mΩ. For lower-power applications that require 600 V with an $R_{DS(on)}$ of > 600 mΩ, we recommend either 600 V CE or 700 P7 devices. 700 V P7 is well suited to the PFC and fly-back stage. 600 V CE is a universal solution that can be used in all low-power topologies with an $R_{DS(on)}$ of > 600 Ω.

Aware that security of supply is a key success factor for our customers, we usually manufacture our products at multiple factories. This aspect might be considered for designs where superior performance of CoolMOS™ can help to differentiate your products from competitors.

CoolMOS™ superjunction MOSFETs for lighting applications

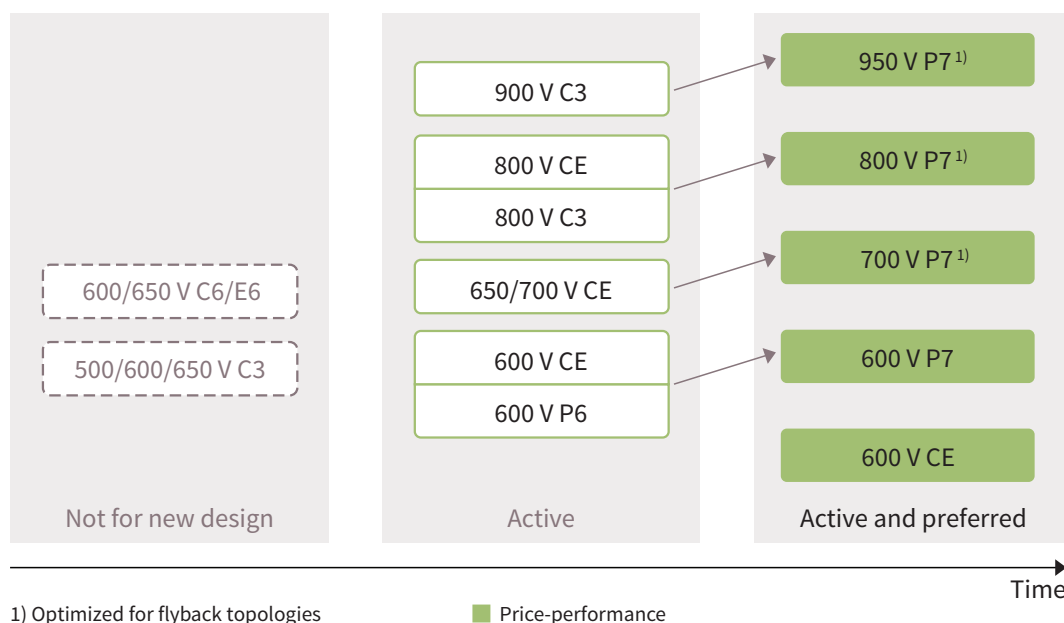

950 V CoolMOS™ P7

Designed to meet growing consumer needs in the high-voltage MOSFET arena, the latest 950 V CoolMOS™ P7 technology focuses on lighting.

Temperature @ 90 V AC

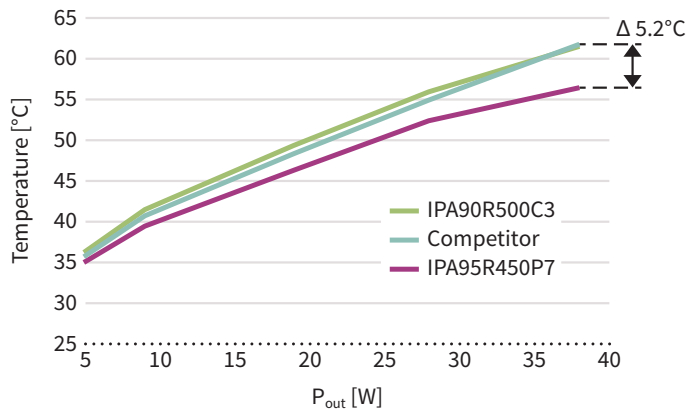

- › The new 950 V CoolMOS™ P7 series delivers best-in-class performance in terms of efficiency, thermal behavior and ease of use. Like all other P7 family members, the 950 V CoolMOS™ P7 series comes with an integrated Zener diode for ESD protection. This integrated diode considerably improves ESD robustness, thus reducing ESD-related yield loss and offering exceptional ease of use.
- › Plug-and-play at 90 V AC in a 40 W adapter reference design, featuring the snubberless concept, demonstrates excellent efficiency gains of up to 0.2 percent, plus lower MOSFET temperatures with drops of up to 5.2°C compared with similar competitor technology.
- › In the DPAK package, the 950 V CoolMOS™ P7 also offers best-in class $R_{DS(on)}$. This SMD device has an $R_{DS(on)}$ of 450 mΩ – more than 60 percent lower than that of the closest competitor.

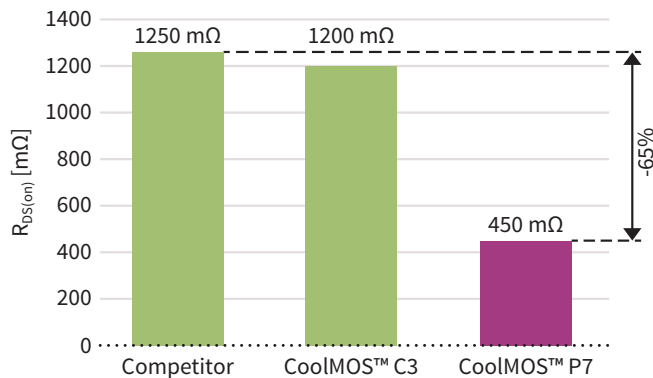

Best-in-class DPAK $R_{DS(on)}$

Customer benefits

- › Option to change from leaded to SMD packages
- › High power density
- › Lower BOM
- › Lower production cost

CoolMOS™ – high-voltage MOSFETs

800 V CoolMOS™ P7

With the 800 V CoolMOS™ P7 series, we have set a benchmark in 800 V superjunction technologies, combining best-in-class performance with remarkable ease of use. This new product family is a perfect fit for flyback-based LED driver applications. It is also suitable for PFC stages, offering a price/performance ratio to meet all market needs.

This technology optimizes key parameters to deliver best-in-class efficiency and thermal performance. As demonstrated through comparisons with a standard, commercially available 80 W LED driver, it reduces switching losses (E_{oss}) and output capacitance (C_{oss}) by more than 45 percent while significantly improving the input capacitance (C_{iss}) and gate charge (Q_G). All of which leads to a 0.5 percent increase in efficiency at light load, which helps to reduce standby power in the end application. At full load, the observed improvement is up to 0.3 percent for efficiency coupled with a 6°C drop in device temperature.

Plug and play in an 80 W LED driver from market

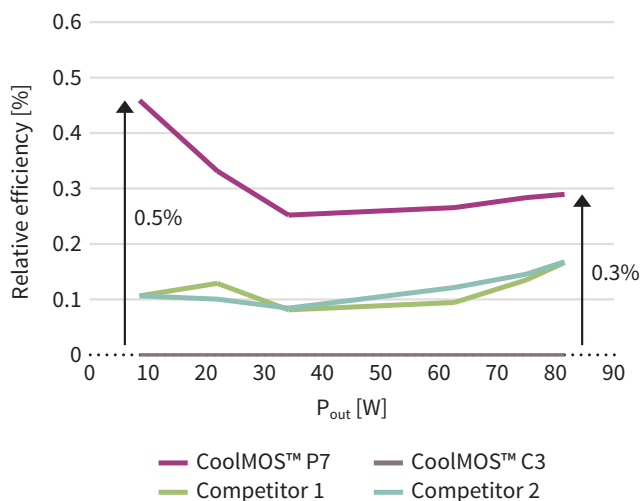

As mentioned in the introduction, the choice of MOSFET will influence system efficiency. Due to benchmark switching losses, the 800 V CoolMOS™ P7 series can achieve very high levels of system efficiency. This efficiency gain relative to market-standard products widens under dimming conditions.

Compared with the competition, the 800 V CoolMOS™ P7 technology allows designers to integrate much lower $R_{DS(on)}$ values into small and cost-effective packages such as DPAK. The same applies to even smaller and low-cost packages like SOT223. The 800 V P7 in a SOT223 package is footprint-compatible with the DPAK.

Overview of lowest DPAK $R_{DS(on)}$ for 800 V superjunction MOSFET

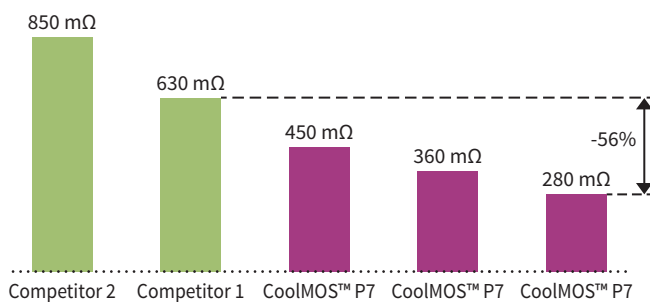

CoolMOS™ P7 sets a new benchmark in best-in-class DPAK $R_{DS(on)}$

Customer benefits

- > High power density
- > Lower BOM
- > Lower production cost

The complete P7 platform has been developed with an integrated Zener diode to protect against electrostatic discharge (ESD). This increases the overall device ruggedness up to Human Body Model (HBM) class 2.

700 V CoolMOS™ P7

Features

- › High-performance technology
 - Low switching losses (E_{oss})
 - Highly efficient
 - Excellent thermal behavior
- › Support for high-speed switching
- › Integrated protection with Zener diode
- › Optimized $V_{GS(th)}$ (3 V) with very narrow tolerance (± 0.5 V)
- › Highly granular portfolio

There are two main use cases for 700 V LED drivers. The main one is as a PFC stage for outdoor lighting, where 600 V might be borderline. For outdoor lighting, some LED driver designs have been deploying 650 V MOSFETs due to higher surge requirements relative to indoor lighting schemes. 700 V CoolMOS™ P7 is a highly cost-effective alternative to the 650 V MOSFETs with the added bonus of extra buffer.

Benefits

- › Cost-competitive technology
- › Further efficiency gain at higher switching speeds
- › Smaller magnetic size with lower BOM
- › High ESD ruggedness up to HBM class 2
- › Easy to drive and design-in
- › Enabler for smaller form factors and high power density designs
- › Best-fit product for demanding applications

The second use case is as a single-stage flyback design for narrow-range systems with 120 V and 230 V input voltages. 800 V MOSFETs will probably remain the devices of choice for single-stage flyback designs. Rising cost pressures for some narrow-range designs may position 700 V as a cost-effective alternative to 800 V MOSFETs.

Relative efficiency @ 230 V_{AC};

$T_{amb} = 25^{\circ}\text{C}$

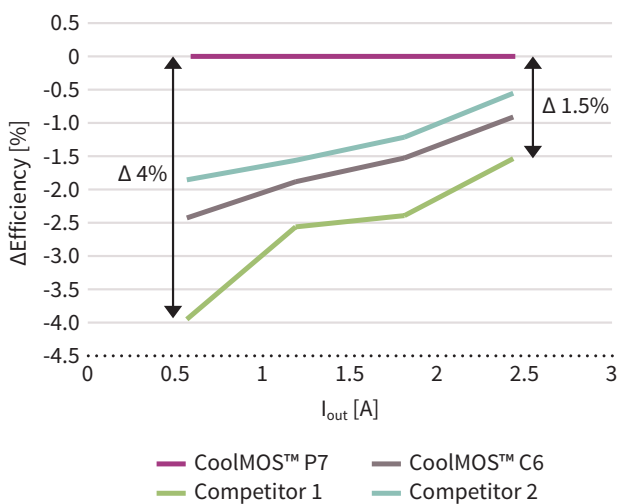

Relative temperature @ 230 V_{AC};

$T_{amb} = 25^{\circ}\text{C}$, 30 min burn-in

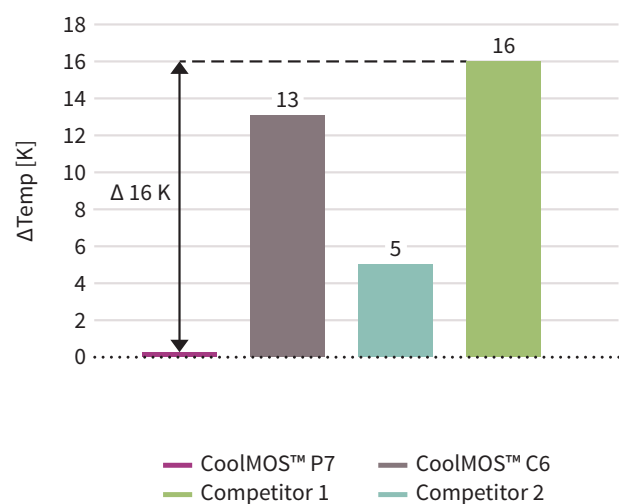

CoolMOS™ – high-voltage MOSFETs

600 V CoolMOS™ P7

The 600 V CoolMOS™ P7 can be used for very different stages within LED drivers.

- > PFC stage
- > Half-bridge stage
- > Buck stage

It offers the highest efficiency and improved power density due to significant reduction in gate charge (Q_G) and switching losses (E_{OSS}) levels, coupled with optimized $R_{DS(on)}$.

The carefully selected integrated gate resistors enable very low ringing tendency. The body diode is exceedingly robust

Features

- > Suitable for hard and soft switching (PFC and LLC) due to outstanding commutation ruggedness
- > Optimized balance between efficiency and ease of use
- > Significant reduction of switching and conduction losses leading to low MOSFET temperature
- > Excellent ESD robustness > 2 kV (HBM) for all products
- > Better $R_{DS(on)}$ /package combinations than the competition
- > Large portfolio with granular $R_{DS(on)}$ values, qualified for a variety of industrial and consumer applications

against hard commutation, making it suited to hard- and soft-switching topologies such as LLC.

In addition, excellent ESD capability helps to improve the manufacturing quality.

The 600 V CoolMOS™ P7 family offers a wide range of $R_{DS(on)}$ /package combinations, including THD and SMD devices, with $R_{DS(on)}$ scaling from 24 to 600 mΩ. This device offers the most competitive price/ performance ratio of all 600 V CoolMOS™ offerings.

Above 600 mΩ, a 600 V CE is recommended.

Benefits

- > Ease of use and fast design-in thanks to low ringing tendency and suitability for PFC and PWM stages
- > Improved efficiency and simplified thermal management due to low switching and conduction losses
- > Higher manufacturing quality due to > 2 kV ESD protection
- > Increased power density by decreasing device footprint
- > Suitable for a wide variety of applications and power ranges

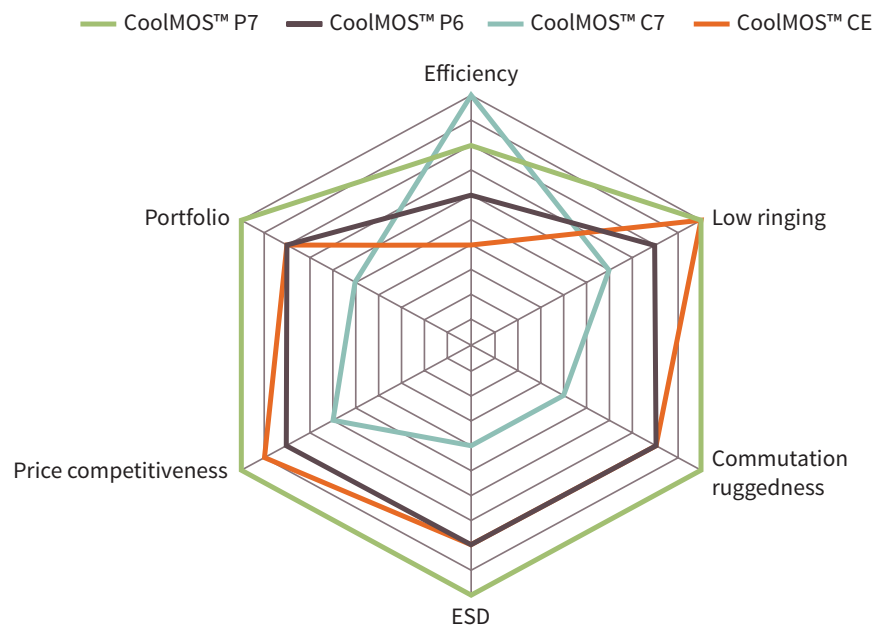

OptiMOS™ 5 – medium-voltage MOSFETs

150 V OptiMOS™ 5 for synchronous rectification

The wide OptiMOS™ portfolio ranging from 100 V to 250 V enables the highest efficiency levels in synchronous rectification. OptiMOS™ consistently sets the benchmark for key design success factors including $R_{DS(on)}$, leading to reduced power losses and improved overall efficiency.

Features

- › Ultra-low reverse recovery charge
- › Suitable for low-voltage drives
- › $R_{DS(on)}$ up to 25 percent lower than next-best alternative in SuperSO8
- › Q_{rr} without compromising FOM_{gd} and FOM_{OSS}

Benefits

- › Increased commutation ruggedness
- › Significant drop in design effort
- › Optimized system efficiency

OptiMOS™ 150 V normal level

$R_{DS(on)}$ max @ $V_{GS} = 10$ V [mΩ]	TO252 (DPAK)	SuperSO8
16–30	IPD200N15N3 G $R_{DS(on)} = 20.0$ mΩ	BSC190N15NS3 G $R_{DS(on)} = 19.0$ mΩ
30–60	IPD530N15N3 G $R_{DS(on)} = 53.0$ mΩ	BSC360N15NS3 G $R_{DS(on)} = 36.0$ mΩ
		BSC520N15NS3 G $R_{DS(on)} = 52.0$ mΩ

$R_{DS(on)}$ max @ $V_{GS} = 10$ V [mΩ]	TO-263 D ² PAK	TO-263 D ² PAK 7pin	TO-262 I ² PAK	TO-220	SuperSO8 PQFN 5 x 6	PQFN 3.3 x 3.3
4.0–5.1	IPB048N15N5 $R_{DS(on)} = 4.8$ mΩ	IPB044N15N5 $R_{DS(on)} = 4.4$ mΩ	IPI051N15N5 $R_{DS(on)} = 5.1$ mΩ	IPP051N15N5 $R_{DS(on)} = 5.1$ mΩ		
5.2–11.0	IPB073N15N5 $R_{DS(on)} = 7.3$ mΩ	IPB060N15N5 $R_{DS(on)} = 6.0$ mΩ	IPI076N15N5 $R_{DS(on)} = 7.6$ mΩ	IPP076N15N5 $R_{DS(on)} = 7.6$ mΩ	BSC093N15NS5 $R_{DS(on)} = 9.3$ mΩ	
					BSC110N15NS5 $R_{DS(on)} = 11.0$ mΩ	
> 11.0					BSC160N15NS5 $R_{DS(on)} = 16.0$ mΩ	BSZ300N15NS5 $R_{DS(on)} = 30.0$ mΩ

NFC IC for configuration

NLM0010/NLM0011

Infineon's NLM0011 is a dual-mode NFC wireless configuration IC with CLO and Pulse Width Modulation (PWM) output, primarily designed for LED applications to enable NFC programming. In addition, advanced features such as the Constant Lumen Output (CLO) as well as the on/off counting are integrated, with no need for an additional microcontroller. The NLM0010 is a light version of the NLM0011 without CLO function.

Features

- › Configurable Pulse Width Modulation (PWM) output
- › NFC contactless interface compliant with ISO/IEC 18000-3 mode 1 (ISO/IEC 15963)
- › Constant Lumen Output (CLO) with 8 configurable points for NLM0011
- › Integrated operation-time counter (OTC) and on/off counter
- › Non-Volatile Memory (NVM) including UID

Benefits

- › Fast and cost-effective implementation of NFC programming and CLO without the need for an additional microcontroller
- › Compatible with most analog LED driver designs using “plug-in resistor” method
- › Stable PWM output with fixed 2.8 V amplitude and $\pm 0.1\%$ duty cycle accuracy
- › Internal voltage regulator (LDO) to avoid influence of unstable external supply voltage

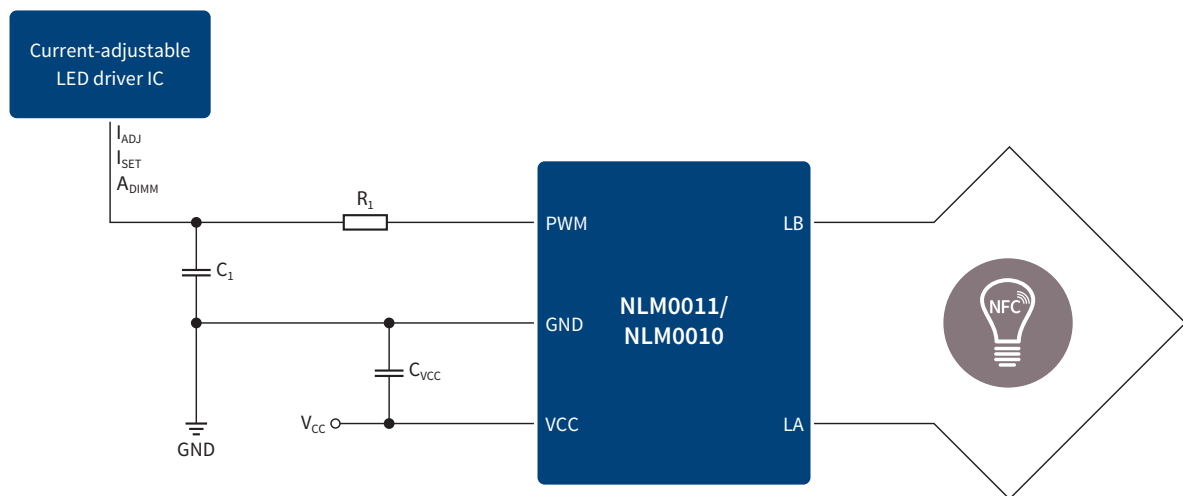

Application note

Name	Description
NLM0011	Dual-mode NFC configuration IC with PWM output and CLO function
NLM0010	Dual-mode NFC configuration IC with PWM output, without CLO function

Evaluation board

Name	Products	Description	Order number
NLM0011 Evaluation Board	EVAL_NLM0011_DC	NLM0011 EVAL KIT W/O NFC READER	EVALNLM0011DCTOBO1

0–10 V dimming interface IC

CDM10V – integrated analog-to-PWM converter for 0–10 V dimming

Features

- › Simplest 0–10 V dimming IC with default settings
 - 5% minimum duty cycle
 - 1 kHz PWM frequency
 - 200 μA dimmer/resistor bias current
 - Dim-to-off disabled
- › The simple one-time programmable option allows setting selection in a wide range
 - Minimum duty cycle: 1%, 2%, 5%, 10%
 - PWM output frequency: 200 Hz, 500 Hz, 1 kHz, 2 kHz
 - Dimmer/resistor bias current: 50 μA , 100 μA , 200 μA , 500 μA
 - Dim-to-off: disabled/enabled
- › Wide input V_{CC} range from 11 to 25 V
- › Transparent PWM mode
(PWM bypass mode in dim-to-off-enabled mode)

Benefits

- › Replace many external components with a single chip, reducing BOM and PCB space
- › Minimize variation from device to device thanks to embedded digital signal processing
- › Easily customizable to design requirements
- › Suitable for various V_{CC} scenarios
- › Wide input V_{CC} range from 11 to 25 V
- › Versatile in complex dimming design

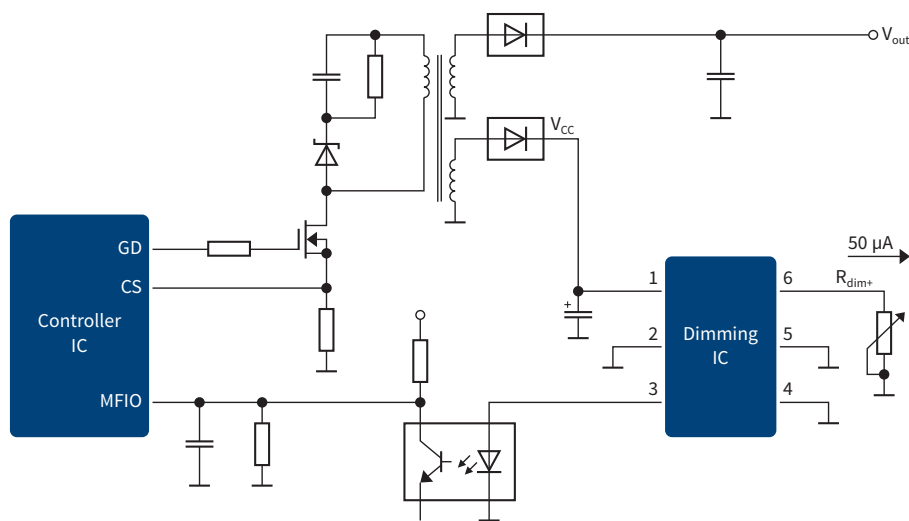

Application note

Name	Description
CoolDim10V Demoboard	40 W reference design with CDM10V isolated 0–10 V dimming interface
COOLDIM_PRG_BOARD	User manual for CDM10V programming board

Evaluation board

Name	Products	Description	Order number
CoolDim10V Demoboard	CDM10V, XDPL8220	CoolDim10V demoboard	SP0016-30060
REF-XDPL8105-CDM10V	CDM10V, XDPL8105	Reference board for XDPL8105 with dimming	SP001649474



LED strips and signage

LED strips are being used everywhere from gas stations to cruise ships in a growing number of applications ranging from channel letters to long LED chains. In commercial applications - where product lifetime as well as a homogeneous

light output are key priorities - constant current sources have been well established for the LED strings. These current sources provide from 10 mA to 200 mA LED current compared to the mainstream range of 20 mA to 100 mA.

Linear LED driver ICs

The BCR linear LED drivers are perfectly suited for driving LED currents from 10 mA to 250 mA, making them the ideal choice for low- to mid-power LEDs in general lighting applications.

This represents the lowest-cost solution that requires an ultra-low external part count and PCB space. The light output can be adjusted via an external resistor. PWM dimming is supported either by a microcontroller interface or by means of an external digital transistor.

Thanks to its negative thermal coefficient, the LED load will be protected from overheating.

The new-generation BCR430U and BCR431U drivers feature an extra-low voltage drop and a smart temperature controlling circuit.



Low-power LED driver ICs (5–65 mA)

Product type	Group	Topology	V_S (min) [V]	V_S (max) [V]	I_{out} (typ) [mA]	I_{out} (max) [mA]	Dimming	Package	P_{tot} (max) [mW]
BCR401U	LED drivers for low-power LEDs	Linear	$1.4 + V_{fLED}$	40	10	65	Digital	SC74	750
BCR401W	LED drivers for low-power LEDs	Linear	$1.2 + V_{fLED}$	18	10	60	Digital	SOT343	500
BCR402U	LED drivers for low-power LEDs	Linear	$1.4 + V_{fLED}$	40	20	65	Digital	SC74	750
BCR402W	LED drivers for low-power LEDs	Linear	$1.4 + V_{fLED}$	18	20	60	Digital	SOT343	500
BCR405U	LED drivers for low-power LEDs	Linear	$1.4 + V_{fLED}$	40	50	65	Digital	SC74	750
BCR431U	LED drivers for low-power LEDs	Linear	6	42	15	42	Digital	SOT23-6	600

Medium- & high-power LED driver ICs (65–500 mA)

Product type	Group	Topology	V_S (min) [V]	V_S (max) [V]	I_{out} (typ) [mA]	I_{out} (max) [mA]	Dimming	Package	P_{tot} (max) [mW]
BCR430U	LED drivers for mid-power LEDs	Linear	6	42	50	100	Digital	SOT23-6	600
BCR320U	LED drivers for mid-power LEDs	Linear	$1.4 + V_{fLED}$	$24 + V_{fLED}$	250	300	No	SC74	1
BCR321U	LED drivers for mid-power LEDs	Linear	$1.4 + V_{fLED}$	$24 + V_{fLED}$	250	300	Digital	SC74	1
BCR420U	LED drivers for mid-power LEDs	Linear	$1.4 + V_{fLED}$	$40 + V_{fLED}$	150	200	No	SC74	1
BCR421U	LED drivers for mid-power LEDs	Linear	$1.4 + V_{fLED}$	$40 + V_{fLED}$	150	200	Digital	SC74	1
BCR450	LED controllers	Linear	3	27	70	ext. switch	Digital	SC74	500
TLE4309G	LED drivers for linear high-power LEDs	Linear	4.5	24	500	500	Digital	TO263	–

Very low-cost LED driver ICs

BCR401W/ BCR402W

Features

- › Up to 500 mW power dissipation in a small SOT343 package
- › Negative thermal coefficient reduces output current at higher temperatures
- › Automotive qualified according to AEC-Q101
- › Suitable for a wide variety of applications and power ranges
- › Output current adjustable by resistor up to 60 mA
- › High-side current control
- › PWM dimmable by external transistor

Benefits

- › Driving current always under control for homogeneous light output
- › Longer lifetime of the LEDs due to reduced output current at higher temperatures (negative thermal coefficient)
- › Easy paralleling of drivers to increase current
- › Stacking of LEDs in front of driver to increase input voltage
- › Contributes to longevity and reliability of LED system

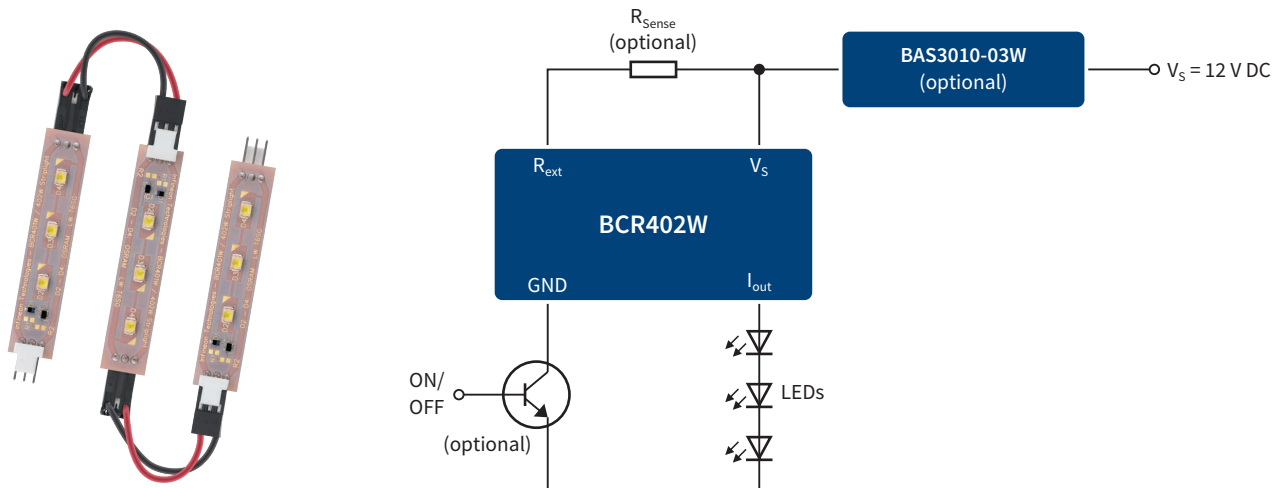

Application note

Name	Description
AN182	Comparison of resistor biasing versus BCR401W/BCR402W LED driver biasing of 12 V & 24 V DC low-current LED strip lights

Evaluation board

Name	Products	Description
12 V low-current LED demoboard	BCR402W BAS3010A-03W	12 V demoboard driving 3x 0.2 W LEDs in series
24 V low-current LED demoboard	BCR402W BAT64-03W	24 V demoboard driving 6x 0.2 W LEDs in series

Low-voltage-drop LED driver ICs

BCR430U/ BCR431U

Features

- > Max. 200 mV voltage drop at driver stage
- > Supply voltage from 6 to 42 V
- > Controls up to 100 mA LED current (BCR430U)
- > Controls up to 42 mA LED current (BCR431U)
- > Smart overtemperature protection

Benefits

- > Very low voltage drop allows use of more LEDs or longer strips overall, which means fewer feeding points.
- > Flexible current setting via resistor
- > Homogeneous light output
- > OTP: protecting not only the lifetime of the IC but also can be used to protect the reliability of the LED strip

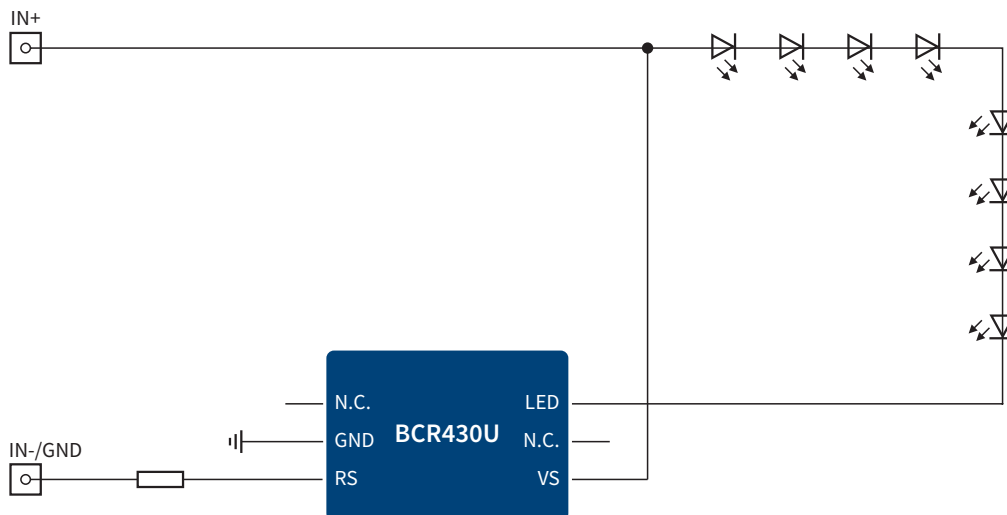

Application note

Name	Description
ER_201704_PL39_0	Engineering report linear LED driver IC BCR430U – features and performance for a 24 V/100 mA (max. LED current) solution, with explanations covering circuit and layout design for the demoboard
ER_2001_PL39_100719_BCR431U_2020-02-10	Engineering report linear LED driver IC BCR431U – features and performance for a 24 V/40 mA (max. LED current) solution, with explanations covering circuit and layout design for the demoboard
BCR431U Low voltage drop LED driver IC App Note	BCR431U – linear LED driver IC with low voltage drop – application note – operation, design guide and performance

Evaluation board

Name	Products	Description	Order number
BCR430U LED BOARD	BCR430U	Low-power demoboard with 8 LEDs, 50 mA	SP001709472
DEMO_BCR431U_LVDROP	BCR431U	Low-power demoboard with 8 LEDs, 15 mA	SP005351261

Robust LED driver ICs

BCR320U/BCR420U

Features

- › Homogeneous light output in different LED strings regardless of V_f and supply voltage
- › Easy to implement with a low component count
- › Flexibility to adjust the current via an external resistor from 10 mA up to 250 mA
- › Automotive qualified according to AEC-Q101

Benefits

- › Direct microcontroller interface for PWM dimming for BCR421U and BCR321U or dimming via PWM power of LEDs
- › Negative thermal coefficient to protect the lifetime of LEDs
- › High power dissipation capability

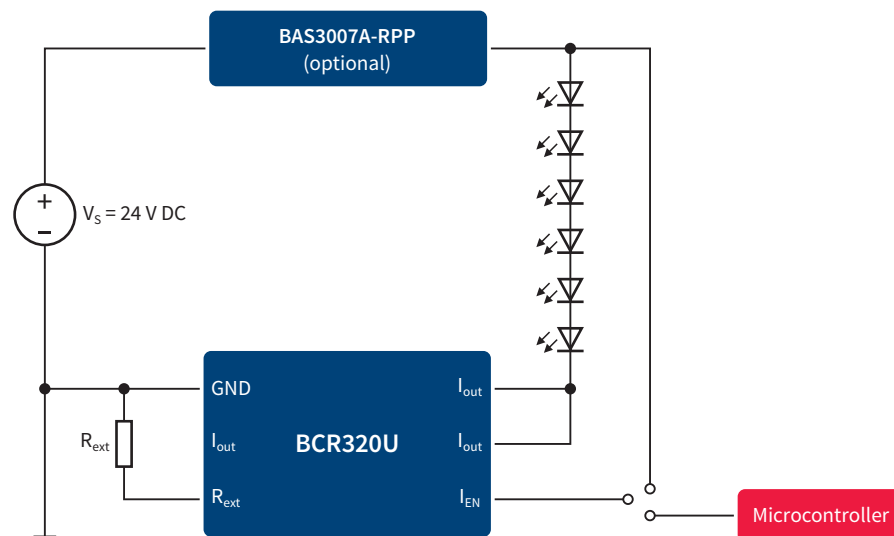

Infineon component list

Product type	Description
BCR320U/BCR321U/BCR420U/BCR421U	Medium-power LED driver
BAS3007A-RPP	Schottky bridge for reverse polarity protection (RPP)

Application note

Name	Description
AN212	Driving half-watt LEDs on a lightstrip with BCR320U, BCR321U or BCR420U, BCR421U

Evaluation board

Name	Products	Description	Order number
24V half-watt LED demoboard	BCR320U BAS3007A-RPP	24 V BCR320U striplight demoboard driving 6x 0.5 W LEDs in series	BCR320U HW LED board

BCR401U/BCR402U/BCR405U

Features

- › LED drive current preset to 10/20/50 mA
- › Output current adjustable by resistor up to 65 mA
- › Supply voltage up to 40 V
- › High-side current control
- › Up to 750 mW power dissipation in a small SC74 package
- › Negative thermal coefficient reduces output current at higher temperatures
- › Automotive qualified according to AEC-Q101

Benefits

- › Driving current always under control for homogeneous light output
- › Longer lifetime of the LEDs due to reduced output current at higher temperatures (negative thermal coefficient)
- › Easy paralleling of drivers to increase current
- › Contributes to longevity and reliability of LED system
- › High power dissipation capability

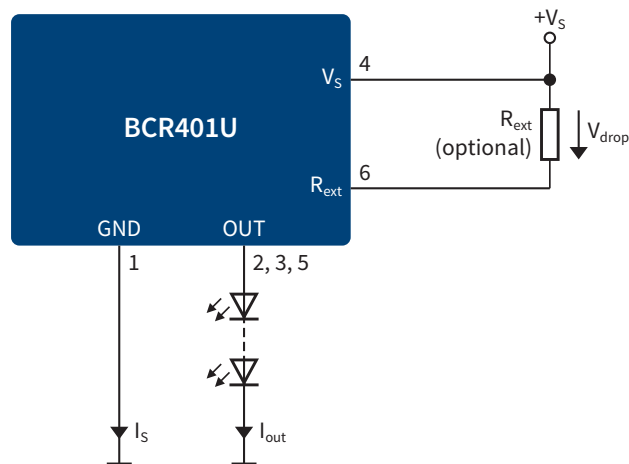
**Application note**

Name	Description
AN182	12 V and 24 V DC low-current LED striplights LED driver biasing using BCR401W/BCR402W vs. resistor biasing (AN182)
AN097	Using BCR402U at high supply voltages
AN101	LEDs from 10 mA to 700 mA driven by BCR4XX (AN101)
AN077	Thermal resistance calculation (AN077)

LED driver ICs for 48 V supply

BCR602 60 V linear LED controller IC for flexible dimming

Features

- > Pure analog dimming down to 3%,
PWM dimming down to 1%
- > V_s from 8 V to 60 V
- > Current precision $\pm 3\%$
- > Overtemperature protection

Benefits

- > Flicker-free deep dimming performance
- > Operating in SELV area, flexible designs with BJT or N-channel MOSFET
- > Current always under control for high light quality
- > Protection of LEDs and system

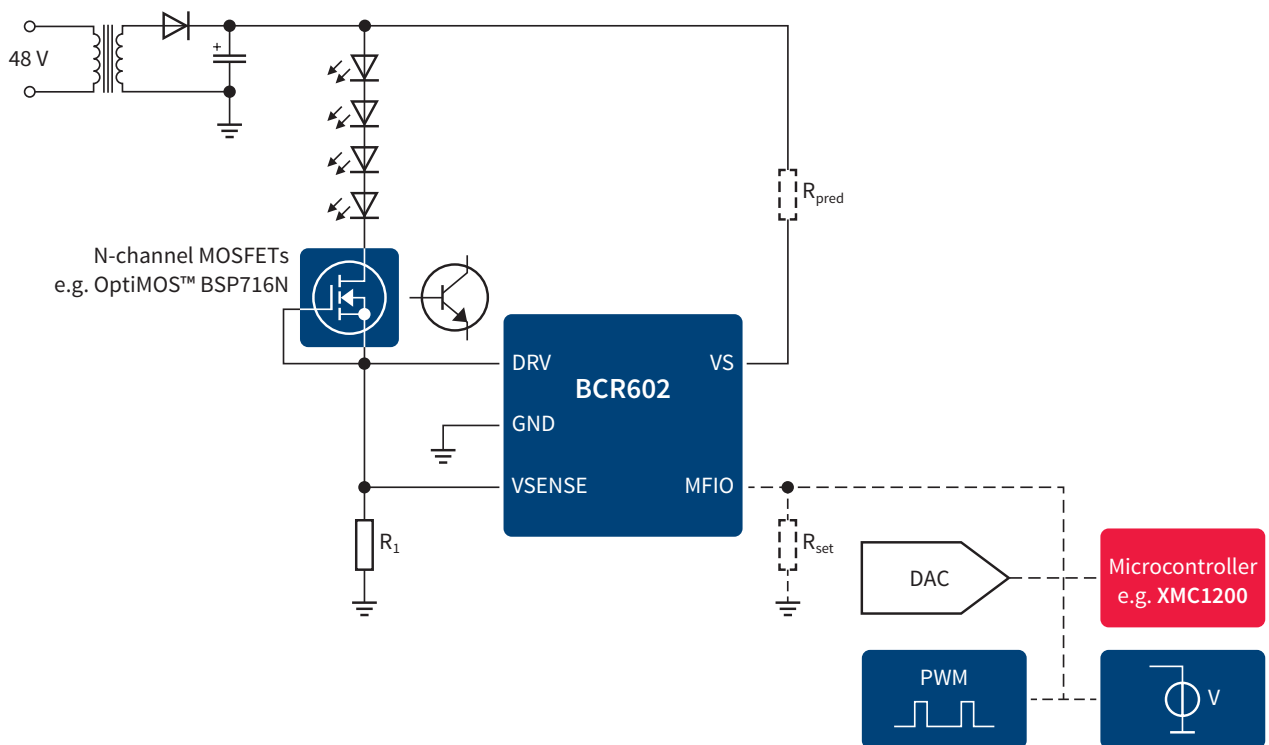

Application note

Name	Description
BCR602 linear LED controller for dimmable applications	Design guide lighting ICs linear LED controller 60 V BCR602 – design guide for a secondary-side-regulated 60 V LED light engine with BCR602
BRC602 engineering report	Engineering report demoboard DEMO_BCR602_60V_ICTRL – engineering report for a 60 V, 200 mA linear LED controller demonstration board

Evaluation board

Name	Products	Description	Order number
DEMO_BCR602_60V_ICTRL	BCR602 BSP716N	Demoboard for design evaluation of cost-efficient, highly reliable, dimmable LED engines/modules, 60 V, 200 mA	SP002798054





Radar sensors for presence detection and more

Passive infrared sensors – in short PIR sensors – are used in numerous lighting applications to save energy. PIR sensors detect the body heat radiated by people. While PIR sensors work well for some applications, certain weaknesses limit their suitability for other use cases. More specifically, these include the following:

- › Limited coverage
- › The opening required for the Fresnel lens complicates design and manufacturing of the lighting fixture
- › Poor sensitivity with regards to radial movements
- › No sensitivity with regards to micro movements when ambient temperature is similar to body temperature

Radar technology overcomes all of these challenges. Since the radar module can be integrated in the lighting fixture, there are no restrictions on the fixture design. In addition, the radar module enables platform solutions that can be used for different types of lighting fixtures. Radar is not temperature-dependent and also works under difficult weather conditions, including fog and rain. The high sensitivity of radar makes it suited to vital sensing applications including the detection of breathing and heart rate.

Furthermore, radar enables new functions like the detection of direction, position and speed. It can also track and count people. All of this extended functionality is enabling new use cases like identifying the usage of meeting rooms and taking the necessary actions for better use of the real estate.

Looking at the many advantages of radar technology, one might wonder why it is not widely used in lighting. In fact, radar has now started to penetrate lighting applications, but a large number of luminaire makers are simply not yet aware of the benefits of this technology. Furthermore, there are some misconceptions around pricing and ease of implementation. Radar solutions may have been expensive in the past, but large-volume deployment in the automotive industry in particular has brought this technology to a more mature, affordable space. Our radar partners already offer a portfolio of certified radar modules to ensure ease of implementation. Given the lively interest in radar solutions among lighting customers, it is likely that this portfolio of radar modules will be expanded further. On the following pages, you will find examples of radar modules offered by some of our radar partners.

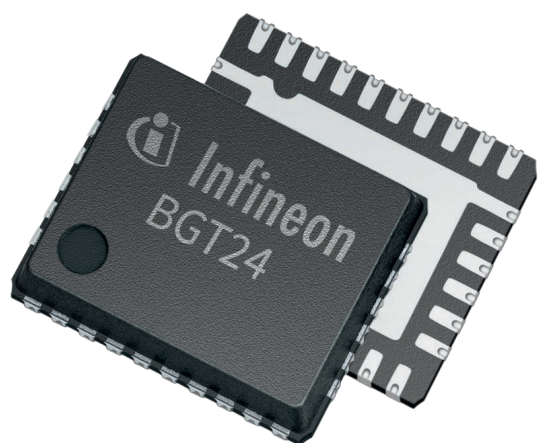

Our partners

Our system design house partners deliver both standard products and customized solutions to fit specific lighting applications from movement detection through automatic light activation to person counting. In addition, they offer all levels of support to get your intelligent lighting system up and running as quickly and efficiently as possible.

Below you can gain an overview of some standard products from RFbeam Microwave GmbH and InnoSenT GmbH. The number of solutions tailored to lighting applications is rapidly expanding – as you can see from our partnership table below.

Radar module – RF beam product

RFbeam

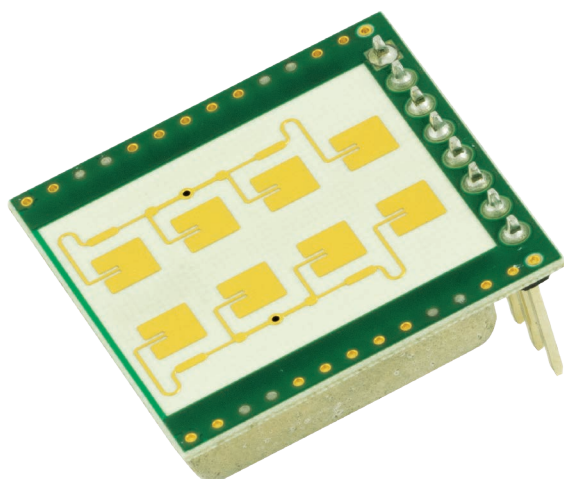

K-LD2 certified radar module

- › Presence detection including slight movements
- › Detection distance up to 15 m (humans) 30 m (cars)
- › Can be hidden in the luminaire
- › Small footprint of 25 x 25 x 6.5 mm
- › 80°/34° beam aperture
- › Sensitivity for micro movements can be adjusted
- › Wide power supply range from 3.2 to 5.5 V
- › Fully certified plug & play solution
- › Very cost-effective solution

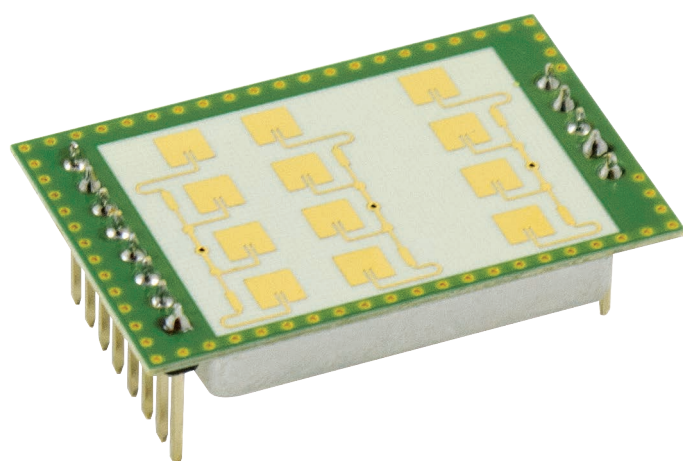

K-LD7 certified radar module

- › Presence detection including slight movements
- › Add-on features like measurement of
 - Distance
 - Direction
 - Angle
- › Detection distance up to 15 m (humans) 30 m (cars)
- › Can be hidden in the luminaire
- › Small footprint of 37 x 25 x 7 mm
- › 80°/34° beam aperture
- › Sensitivity for micro movements can be adjusted
- › Wide power supply range from 3.2 to 5.5 V
- › Fully certified plug & play solution

INS-Series from InnoSenT: Motion and presence detector in one radar system



InnoSenT GmbH from Donnersdorf was founded in 1999 and is one of the world's leading companies in the field of radar technology. As a manufacturer and developer, the company supplies the full bandwidth of engineering services - from customer-specific development to series production. Thanks to the strong focus on quality and innovation, InnoSenT GmbH has been following a course to global success for many years.

INS-313X

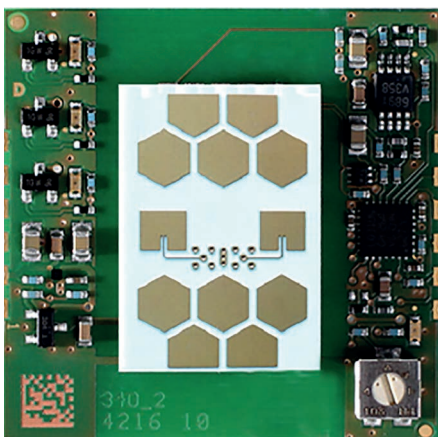

Features

- > Can be concealed behind many materials
- > Motion detection range of up to 5 m for humans
- > Detection range adjustable via potentiometer (only for advanced version INS-3130)
- > Proximity switch for object detection (distances of less than 5 cm)
- > Movement recognition with direction, velocity and signal strength over range from 1.5 to 5 m
- > Advanced version INS-3130 comes with open collector outputs
- > UART interface
- > ECO and standby mode for reduced power consumption
- > Delivered on tape and reel
- > Flat SMD design with 5 mm height

INS-333x

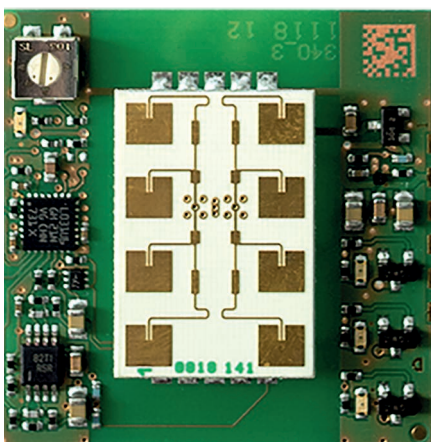

Features

- > Can be concealed behind many materials
- > Motion detection range of up to 10 m for humans
- > Detection range adjustable via potentiometer (only for advanced version INS-3330)
- > Proximity switch for object detection (distances of less than 10 cm)
- > Movement recognition with direction, velocity and signal strength over range from 2 to 10 m
- > Open collector outputs (only for advanced version INS-3330)
- > UART interface
- > ECO and standby mode for reduced power consumption
- > Delivered on tape and reel
- > Flat SMD design with 5 mm height

Radar partner ecosystem at a glance including design house partners

EMEA		
Greenwaves		
24/60/77 GHz	DH	I
InnoSenT		
24/60/77 GHz	M + DH	I/A
NovellC		
24/60/77 GHz	DH	I/A
RFbeam		
24/60/77 GHz	M + DH	I/A

Greater China		
Cheng Tech		
24 GHz	DH	I
Entros		
24 GHz	M + DH	I/A
Honmax		
24 GHz	DH	I
KingCity		
24/60 GHz	DH	I
Nanoradar		
24 GHz	M + DH	I/A
Sensortech		
24 GHz	M + DH	I/A
RichGreenTek		
24 GHz	DH	A
TransMicrowave		
24 GHz	DH	I/A

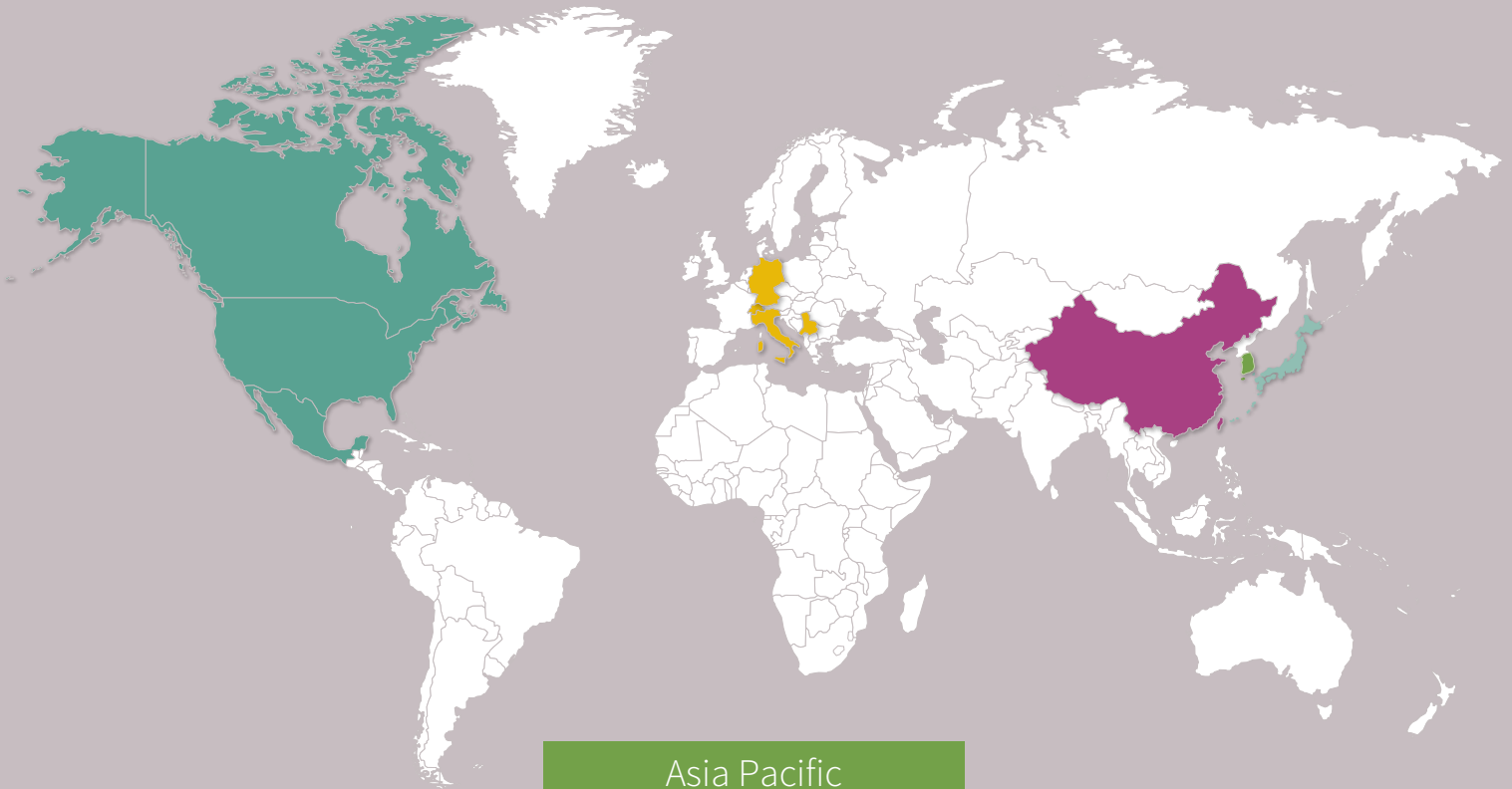

Americas		
Ancortek		
24 GHz	M + DH	I
Colorado Engineering		
24/60/77 GHz	M	I/A
Delta Mobile Systems		
24 GHz	M + DH	I/A
OmniPreSense		
24 GHz	M + DH	I

Asia Pacific		
Bitsensing Inc.		
24/60 GHz	DH	I
Digitaledge Inc.		
24/60 GHz	DH	I
Inzinious		
24 GHz	DH	I/A
M-Clavis		
24/60/77 GHz	M + DH	I
Newest one		
24 GHz	M + DH	I
Wooriro		
24 GHz	M + DH	I

Japan		
PTM		
24/60 GHz	DH	I
Sharp Takaya		
24 GHz	DH	I/A

Abbreviations: M = "Off-the-shelf" radar module provider DH = Design house/customized modules
I = Industrial and consumer applications A = Automotive applications



Where to buy

Infiniteon distribution partners and sales offices:

www.infineon.com/WhereToBuy

Service hotline

Infiniteon offers its toll-free 0800/4001 service hotline as one central number, available 24/7 in English, Mandarin and German.

- > Germany 0800 951 951 951 (German/English)
- > China, mainland 4001 200 951 (Mandarin/English)
- > India 1 800 572 4924 (English)
- > USA 1-866 951 9519 (English/German)
- > Other countries 00* 800 951 951 951 (English/German)
- > Direct access +49 89 234-0 (interconnection fee, German/English)

* Please note: Some countries may require you to dial a code other than "00" to access this international number.
Please visit www.infineon.com/service for your country!

www.infineon.com

Published by
Infineon Technologies AG
81726 Munich, Germany

© 2020 Infineon Technologies AG.
All rights reserved.

Please note!

This Document is for information purposes only and any information given herein shall in no event be regarded as a warranty, guarantee or description of any functionality, conditions and/or quality of our products or any suitability for a particular purpose. With regard to the technical specifications of our products, we kindly ask you to refer to the relevant product data sheets provided by us. Our customers and their technical departments are required to evaluate the suitability of our products for the intended application.

We reserve the right to change this document and/or the information given herein at any time.

Additional information

For further information on technologies, our products, the application of our products, delivery terms and conditions and/or prices, please contact your nearest Infineon Technologies office (www.infineon.com).

Warnings

Due to technical requirements, our products may contain dangerous substances. For information on the types in question, please contact your nearest Infineon Technologies office.

Except as otherwise explicitly approved by us in a written document signed by authorized representatives of Infineon Technologies, our products may not be used in any life-endangering applications, including but not limited to medical, nuclear, military, life-critical or any other applications where a failure of the product or any consequences of the use thereof can result in personal injury.