

AN-EVALSF3-ICE3B2065P

40W 18V SMPS Evaluation Board with
CoolSET™ F3 ICE3B2065P

Power Management & Supply



N e v e r s t o p t h i n k i n g .

Edition 2006-07-18

**Published by Infineon Technologies Asia Pacific,
168 Kallang Way,
349253 Singapore, Singapore**

**© Infineon Technologies AP 2004.
All Rights Reserved.**

Attention please!

The information herein is given to describe certain components and shall not be considered as a guarantee of characteristics.

Terms of delivery and rights to technical change reserved.

We hereby disclaim any and all warranties, including but not limited to warranties of non-infringement, regarding circuits, descriptions and charts stated herein.

Information

For further information on technology, delivery terms and conditions and prices please contact your nearest Infineon Technologies Office (www.infineon.com).

Warnings

Due to technical requirements components may contain dangerous substances. For information on the types in question please contact your nearest Infineon Technologies Office.

Infineon Technologies Components may only be used in life-support devices or systems with the express written approval of Infineon Technologies, if a failure of such components can reasonably be expected to cause the failure of that life-support device or system, or to affect the safety or effectiveness of that device or system. Life support devices or systems are intended to be implanted in the human body, or to support and/or maintain and sustain and/or protect human life. If they fail, it is reasonable to assume that the health of the user or other persons may be endangered.

ABSTRACT	5
1 EVALUATION BOARD (18V, 2.22A).....	5
2 LIST OF FEATURES	6
3 TECHNICAL SPECIFICATION.....	6
4 SCHEMATIC.....	7
5 PCB.....	8
5.1 COMPONENT SIDE COMPONENT LEGEND	8
5.2 SOLDER SIDE COPPER	9
6 CIRCUIT DESCRIPTION.....	10
6.1 LINE INPUT	10
6.2 POWER CONTROL AND POWER STAGE.....	10
6.3 STARTUP.....	10
6.4 SOFT START	10
6.5 OPERATION MODE	10
6.6 CLAMPING NETWORK	10
6.7 PRIMARY CURRENT SENSE.....	10
6.8 OUTPUT STAGE	11
6.9 FEEDBACK LOOP	11
6.10 BLANKING WINDOW FOR LOAD JUMP / ACTIVE BURST MODE.....	11
6.11 ACTIVE BURST MODE.....	11
7 COMPONENT LIST.....	12
8 TRANSFORMER CONSTRUCTION.....	13
9 TEST RESULTS.....	14
9.1 LINE / LOAD REGULATION MATRIX TABLE	14
9.2 EFFICIENCY	15
9.3 INPUT STANDBY POWER	15
10 TEST WAVEFORMS.....	16
10.1 START UP (TURN ON AT FULL LOAD)	16
10.2 ACTIVE BURST MODE (ZERO LOAD).....	16
10.3 ENTER ACTIVE BURST MODE (FULL LOAD TO ZERO LOAD)	17
10.4 LEAVE ACTIVE BURST MODE TO NORMAL MODE (ZERO LOAD TO FULL LOAD)	17
10.5 SHORT CIRCUIT PROTECTION (SHORT AT FULL LOAD)	18
10.6 VCC OVERVOLTAGE PROTECTION (TURN ON AT ZERO LOAD WHILE LOOP OPENED).....	18
10.7 OPEN LOOP PROTECTION (TURN ON AT FULL LOAD WHILE LOOP OPENED).....	19
10.8 OVER LOAD PROTECTION (LOAD JUMP FROM 2.22A TO 4A)	19
11 REFERENCE.....	20

Abstract

This application note is a description for a 40W switching mode power supply evaluation board designed in a typical off-line flyback converter topology that utilizes the ICE3B2065P F3 CoolSET™¹. The application operates in discontinuous conduction mode and is especially suitable for applications such as an AC/DC power supply for LCD monitor, DVD player and set-top box, adapter for printer and notebook computer as well as auxiliary power supply for higher power system. Designed based on the proven technology of F2 CoolSET™ ICE2xxxx, the F3 CoolSET™ provides Active Burst Mode to reach the lowest Standby Power Requirement at less than 100mW during no load condition. In Active Burst Mode the ripple of the output can also be reduced to less than 1%. Furthermore, an adjustable Blanking Window by varying the value of Soft Start capacitor is being offered to support applications which needs surge power for a limited period of time (e.g. switching on capacitive loads).

1 Evaluation Board (18V, 2.22A)



Figure 1 - EVALSF3-ICE3B2065P

This document contains the list of features, the power supply specification, schematic, bill of material and the transformer construction documentation. Typical operating characteristics are presented at the rear of the report and consist of performance curves and scope waveforms.

¹ CoolSET™ is a current mode PWM control IC and the power MOSFET CoolMOS™ within one package designed for low cost switch mode power supplies (SMPS).

2 List of features

<ul style="list-style-type: none"> • 650V avalanche rugged CoolMOS™ with built in switchable Startup Cell.
<ul style="list-style-type: none"> • Active Burst Mode for lowest Standby Power @ light load controlled by Feedback signal.
<ul style="list-style-type: none"> • Fast load jump response in Active Burst Mode.
<ul style="list-style-type: none"> • 67kHz fixed switching frequency.
<ul style="list-style-type: none"> • Auto Restart Mode for Overtemperature Detection, Overvoltage Detection, Overload, Open Loop and VCC Undervoltage.
<ul style="list-style-type: none"> • Blanking Window for short duration high current.
<ul style="list-style-type: none"> • User defined Soft Start.
<ul style="list-style-type: none"> • Max Duty Cycle 72%.
<ul style="list-style-type: none"> • Overall tolerance of current limiting <math>< \pm 5\%</math>.
<ul style="list-style-type: none"> • Internal Leading Edge Blanking.
<ul style="list-style-type: none"> • Soft driving for low EMI.

3 Technical Specification

Input Voltage	85Vac ~ 265Vac
Input Frequency	50Hz, 60Hz
Output Voltage and Current	18V, 2.22A
Output Power	40W
Efficiency	>75% at full load

4 Schematic

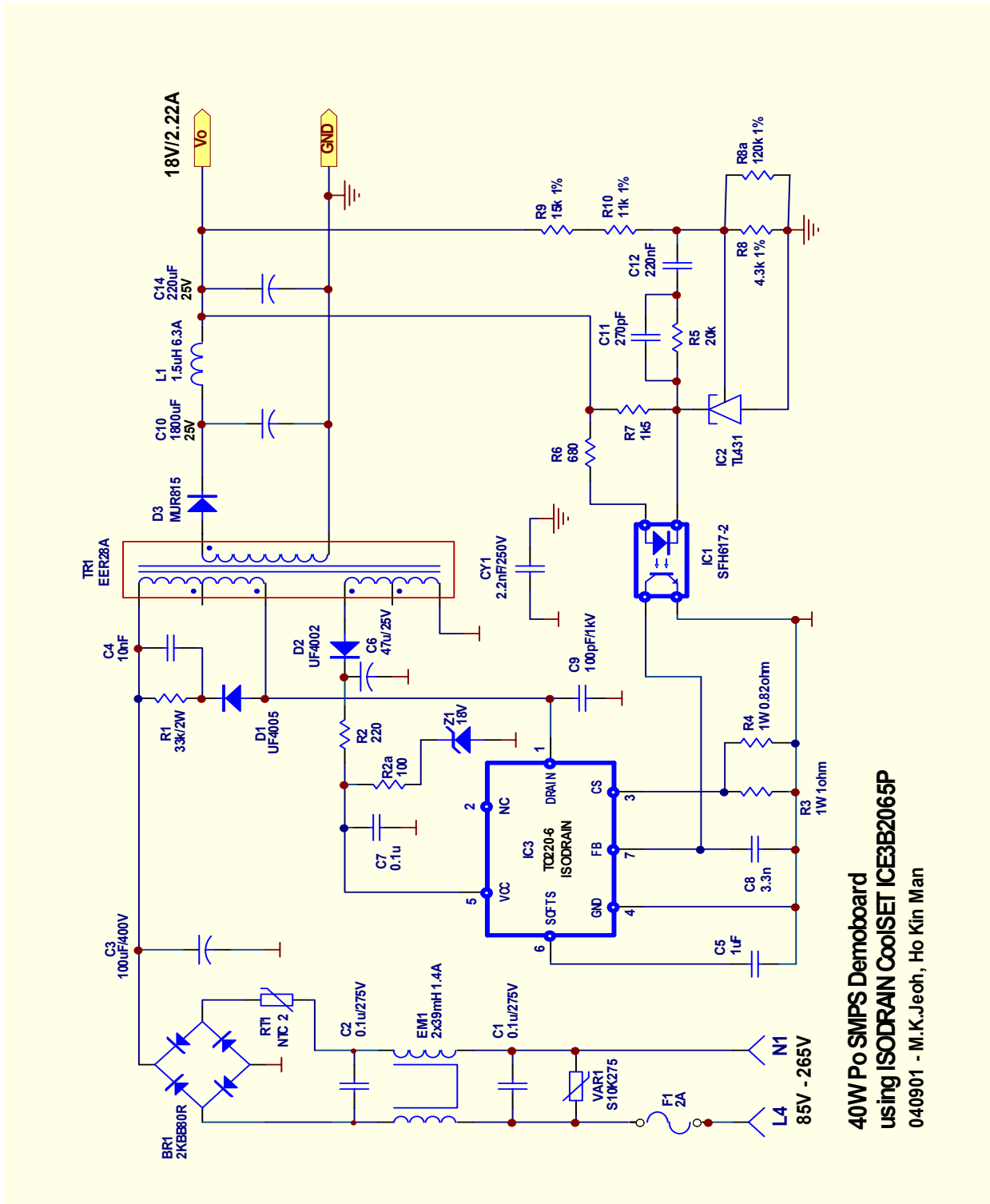

Figure 2 - 40W 18V ICE3B2065P power supply Schematic

5 PCB

5.1 Component Side component Legend

40W SMPS with ICE3B2065P – 060606–JMK

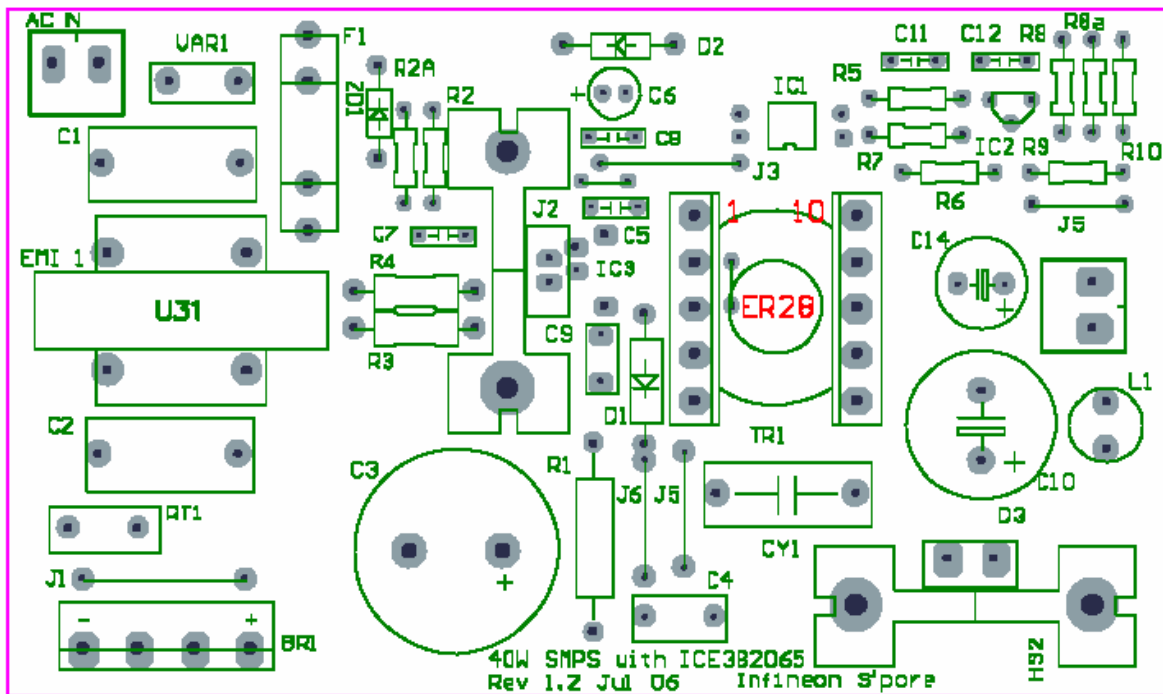

Figure 3 - Component side Component Legend – View from Component Side

5.2 Solder Side Copper

40W SMPS with ICE3B2065P – D60606–JMK

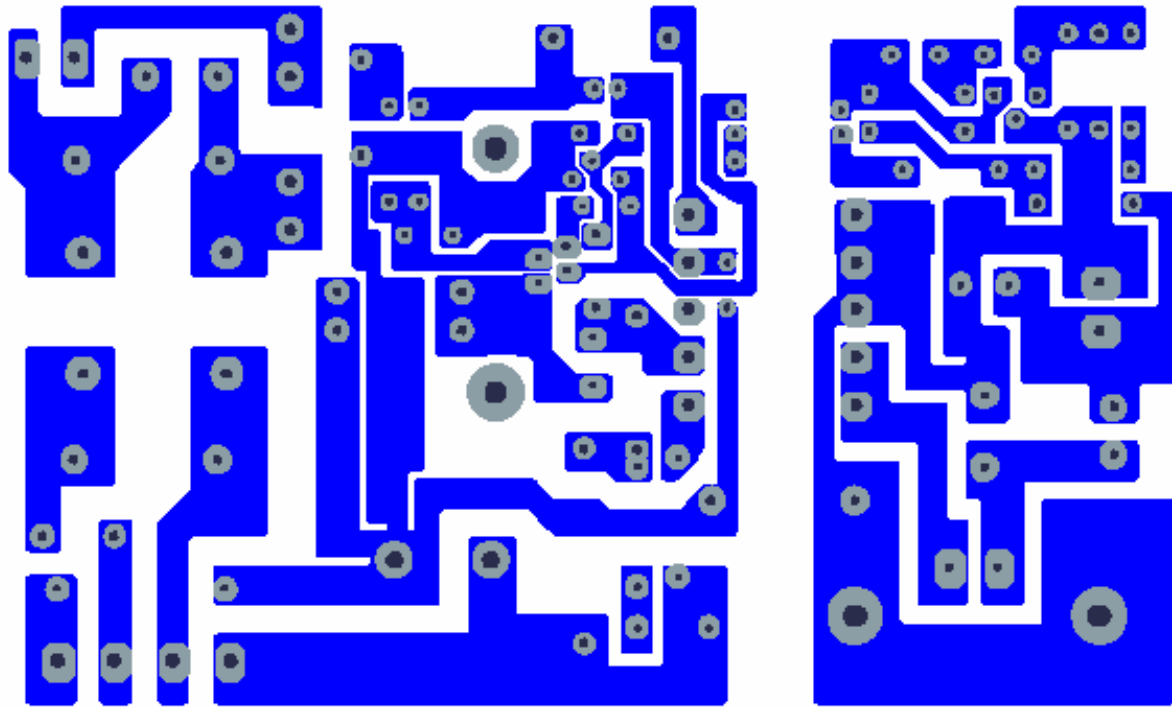

Figure 4 – Solder side Copper – View from Component Side

6 Circuit Description

6.1 Line Input

The AC line input side comprises the input fuse F1 as over-current protection. The choke EM11, X2-capacitors C1, C2 and Y2-capacitor CY1 act as radio interference suppressors. After the bridge rectifier BR1 and the input capacitor C3, there is a voltage of 90 to 380 VDC depending on input voltage. The varistor VAR1 after fuse can absorb the input surge transient voltage and the thermistor RT1 can limit the input inrush current during the first plug in of the AC input line.

6.2 Power Control and Power Stage

The PWM pulse is generated by the 6-pin CoolSET™F3 ICE3B2065P. ICE3B2065P is an integrated power IC which includes the current-mode PWM controller and a CoolMOS™ with 650V breakdown voltage. The control IC and CoolMOS™ are fabricated by different optimized chip technologies and no compromise monolithic approaches is necessary.

6.3 Startup

Since there is a built-in startup cell in the ICE3B2065P, there is no need for external start up resistor. The startup cell is connecting the drain pin of the IC. Once the voltage is built up at the Drain pin of the ICE3B2065P, the startup cell will charge up the Vcc capacitor C6 and C7. When the Vcc voltage exceeds the UVLO at 15V, the IC starts up. Then the Vcc voltage is bootstrapped by the auxiliary winding to sustain the operation.

6.4 Soft start

The Soft-Start function is realized by an internal resistor and the adjustable external capacitor C5.

6.5 Operation mode

During operation, the Vcc pin is supplied via a separate transformer winding with associated rectification D2 and buffering C6, C7. Resistor R2 is used for current limiting. In order not to exceed the maximum voltage at Vcc pin an external zener diode Z1 and resistor R2a is added to limit this voltage. C9 can reduce the switching speed and reduce the switching noise.

6.6 Clamping Network

The circuit R1, C4 and D1 clamp the DRAIN voltage spike caused by transformer leakage inductance to a safe value below the drain source break down voltage $V_{DSBR} = 650V^1$ maximum.

6.7 Primary Current Sense

The primary current is sensed by the external shunt resistor R3, R4. The sense voltage is fed into ICE3B2065P and a cycle by cycle current limiting is achieved. Primary current is being converted to a corresponding voltage level at CS (I_{sense}) pin. A 220ns leading edge blanking is provided to avoid leading edge spikes from distorting the current limiting.

¹ $V_{DSBR} = 650V @ T_j = 110^\circ C$

6.8 Output Stage

On the secondary side the power is coupled out by an ultra-fast diode D3. The capacitor C10 provide energy buffering followed with the LC filter, L1 and C14 to reduce the output voltage ripple considerably. Storage capacitor C10 is selected to have an internal resistance as small as possible (ESR) to minimize the output voltage ripple.

6.9 Feedback Loop

The output voltage is sensed by the voltage divider of R9, R10, R8 and R8a and compare to the TL431 internal reference voltage. The output voltage of TL431, IC2 is transferred to the primary via an optocoupler, IC1 for regulation control. The secondary regulation control is adopted with TL431 and optocoupler. C11, C12, R5 being the compensation network constitutes the external circuitry of the error amplifier of TL431. The circuitry allows the feedback to be precisely matched to dynamically varying load conditions, thereby providing stable control. The maximum current through the optocoupler diode and the voltage reference is limited by the resistor R6 and R7. Optocoupler IC1 is used for floating transmission of the control signal to the 'FB' input of the ICE3B2065P. Filter capacitor C8 at FB pin of the IC3B2065P is used to eliminate the noise.

6.10 Blanking Window for Load Jump / Active Burst Mode

In case of load jump the controller provides a Blanking Window before activating the Overvoltage Protection and enters the Auto Restart Mode. The timeframe is generated by charging up the Soft Start capacitor C5 from 4.4V to 5.4V. Within this timeframe the voltage at Feedback pin can rise up above 4.8V, without switching off. During this operation the transferred power is limited to the maximum peak current defined by the value of the current sense resistor R3 and R4. The same procedure happens to the external Soft Start capacitor C5 if a low load condition is detected when V_{FB} is falling below 1.32V. Only after V_{SOFTS} has exceeded 5.4V and V_{FB} is still below 1.32V, Active Burst Mode is activated.

6.11 Active Burst Mode

At light load condition the SMPS enters into Active Burst Mode. The controller is always active at this state. V_{CC} must therefore be above the switch off threshold $V_{COFF} = 8.5V$. While supporting low ripple on V_{OUT} and fast response on load jump, efficiency also increased significantly during Active Burst Mode. When the voltage level at FB falls below 1.32V, Soft start capacitor C5 at SOFTST pin is allowed to charge starting from the clamped voltage level at 4.4V in Normal Operating Mode. Active Burst Mode is entered once V_{SOFTST} exceeds 5.4V. A Blanking Window as mentioned earlier which can be adjusted by manipulating C5 is generated to avoid a sudden entering of Burst Mode due to load jump.

During Active Burst Mode the current sense voltage limit at CS (I_{SENSE}) pin, V_{CS} , is set to 0.257V to reduce the conduction losses. All the internal circuits are switched off except the reference and bias voltages to reduce the total V_{CC} current consumption to below 1.1mA. The FB voltage is changing like a sawtooth between 3.4 and 4V. To leave Burst Mode, FB voltage must exceed 4.8V as a result of increase loading. This resets the Active Burst Mode and turns the SMPS into Normal Operating Mode. Maximum current can now be provided to stabilize V_{OUT} .

7 Component List

Designator	Part Type	Description	QTY
BR1	2KBB80R	Bridge Rectifier 800Vrms 1.5A	1
C1	0.1uF 275V	X2 Capacitor	1
C2	0.1uF 275V	X2 Capacitor	1
C3	100uF/400V	Bulk Capacitor	1
C4	10nF 1kV	Snubber Capacitor	1
C5	1uF 50V	Soft Start Capacitor	1
C6	47uF/25V	Vaux Capacitor	1
C7	0.1u 50V	Vcc Capacitor	1
C8	3.3n 50V	Vfb Capacitor	1
C9	100pF/1kV	Drain Source Capacitor	1
C10	1800uF 25V	Output Capacitor	1
C11	270pF 50V	Feedback Capacitor	1
C12	220nF50V	Feedback Capacitor	1
C14	220uF 25V	Output Capacitor	1
CY1	2.2nF/250V	Y1 Capacitor	1
D1	UF4005	Snubber Diode	1
D2	UF4002	Vaux Diode	1
D3	MUR815	Secondary Rectifier	1
EMI1	2x39mH 1.4A	Common Mode Choke	1
F1	2A 250V	Fuse	1
IC1	SFH617-2	Opto Coupler	1
IC2	TL431	Feedback Amplifier, Voltage Ref	1
IC3	ICE3B2065P	2.0A IsoDrain CoolSET	1
L1	1.5uH 6.3A	Output Choke	1
PCB	Rev. 1.0	Rev. 1.0 PCB	1
R1	33k/2W	Snubber Resistor	1
R2	220	Vaux Resistor	1
R2a	100	Resistor at Zenor	1
R3	1ohm 1W	Current Sensor Resistor	1
R4	0.82ohm 1W	Current Sensor Resistor	1
R5	20k	Feedback Resistor	1
R6	680	Resistor at Optocoupler	1
R7	1k5	TL431 bias resistor	1
R8	4.3k 1%	Regulation Resistor	1
R8a	120k 1%	Regulation Resistor	1
R9	15k 1%	Feedback, Regulation Resistor	1
R10	11k 1%	Feedback, Regulation Resistor	1
RT1	NTC 1ohm	NTC Thermister	1
TR1	EER28A bobbin	EER28L transformer	1
VAR1	S10K275	Varistor	1
Z1	18V	18V 1/2W zener	1

8 Transformer Construction

Core and material : BH1 or N67

Bobbin: ER28A (10pin) Vertical Version

Primary Inductance $L_p = 340 \mu\text{H} \pm 3\%$, measured between pin 4, pin 5 (Gapped to Inductance)

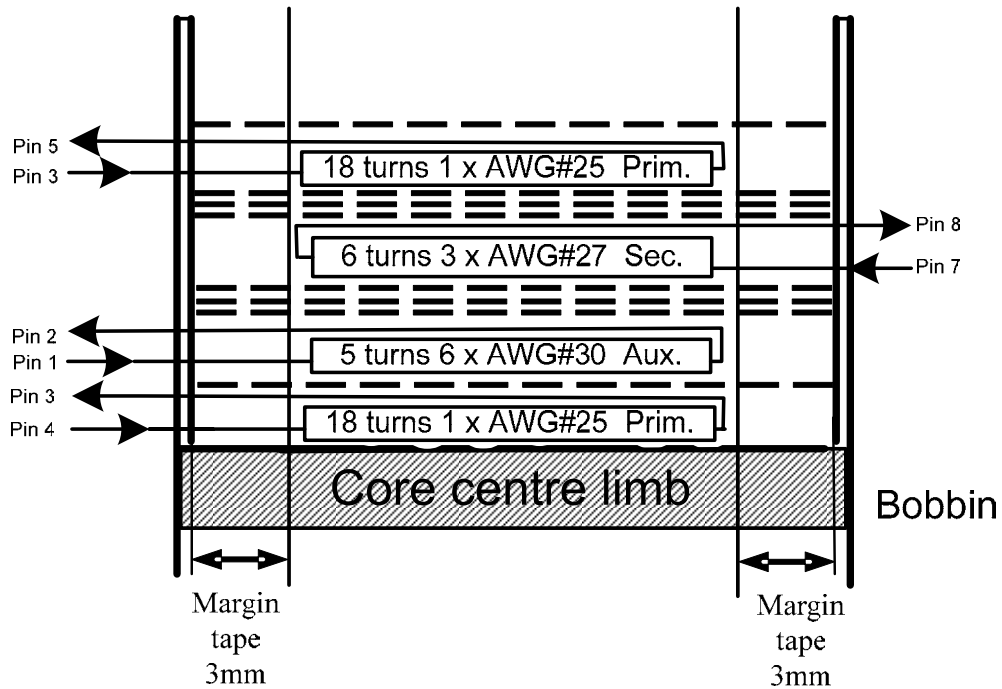

Figure 5 – Transformer structure

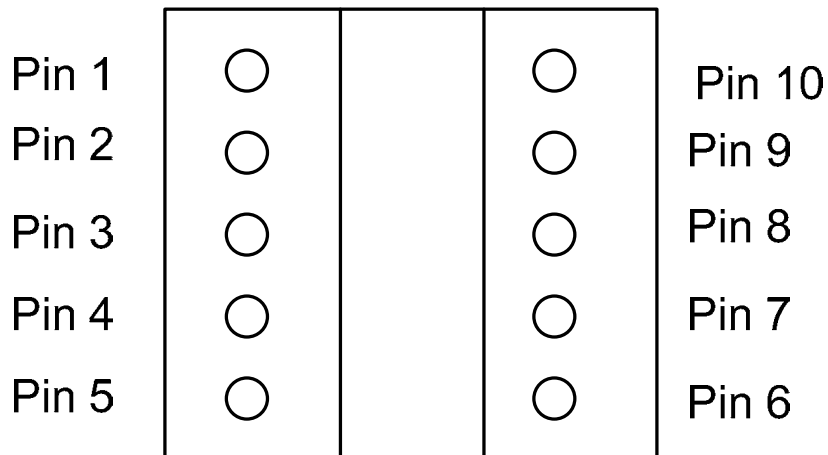

Figure 6 – Transformer complete – top view

9 Test Results

9.1 Line / Load Regulation matrix table

V_{in} (Vac)	I_o (A)	V_o (V)	P_{in} (W)	Efficiency (%)
85	0.5	18.12	11.52	78.65
	1.2	18.12	26.94	80.71
	2.22	18.12	51.81	77.64
90	0.5	18.12	11.48	78.92
	1.2	18.12	26.84	81.01
	2.22	18.12	51.38	78.29
120	0.5	18.12	11.36	79.75
	1.2	18.11	26.35	82.47
	2.22	18.12	49.5	81.27
150	0.5	18.12	11.5	78.78
	1.2	18.11	25.97	83.68
	2.22	18.11	48.52	82.86
180	0.5	18.12	11.47	78.99
	1.2	18.11	25.93	83.81
	2.22	18.11	48.27	83.29
220	0.5	18.12	11.42	79.33
	1.2	18.11	26.19	82.98
	2.22	18.11	47.57	84.52
265	0.5	18.12	11.64	77.84
	1.2	18.11	26.29	82.66
	2.22	18.11	47.72	84.25

9.2 Efficiency

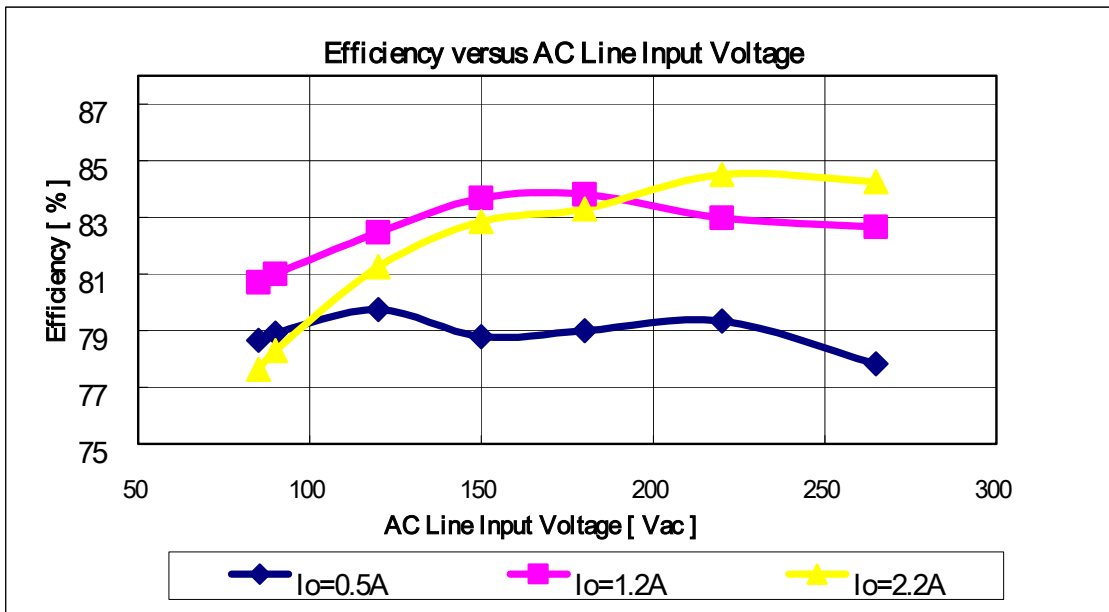

Figure 7 – Efficiency vs AC Line Input Voltage

9.3 Input Standby Power

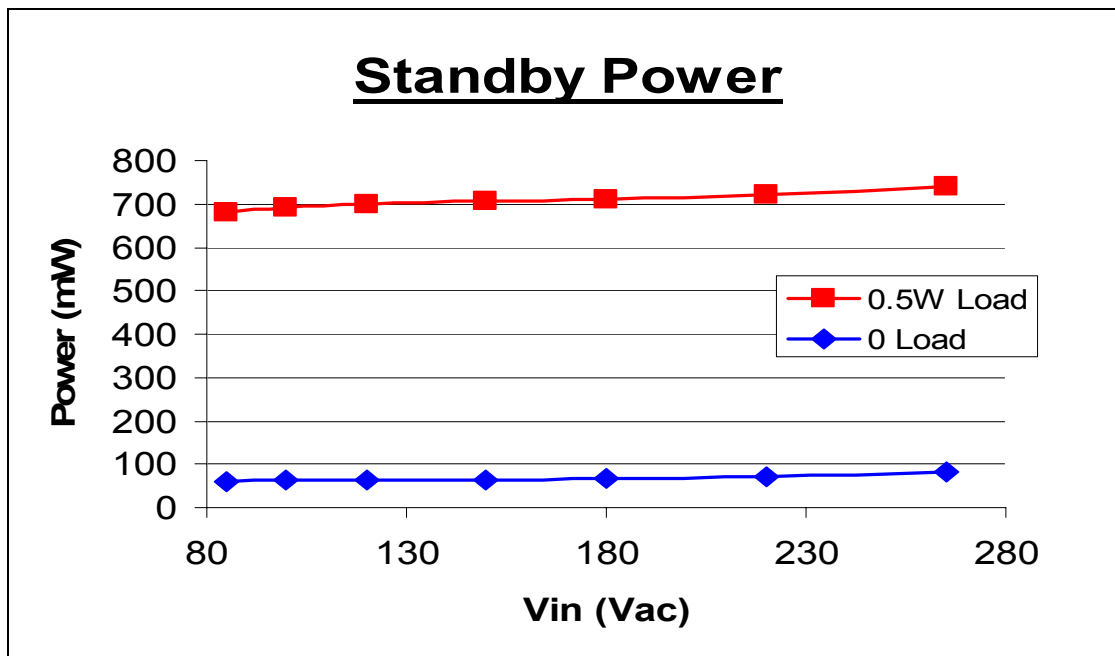
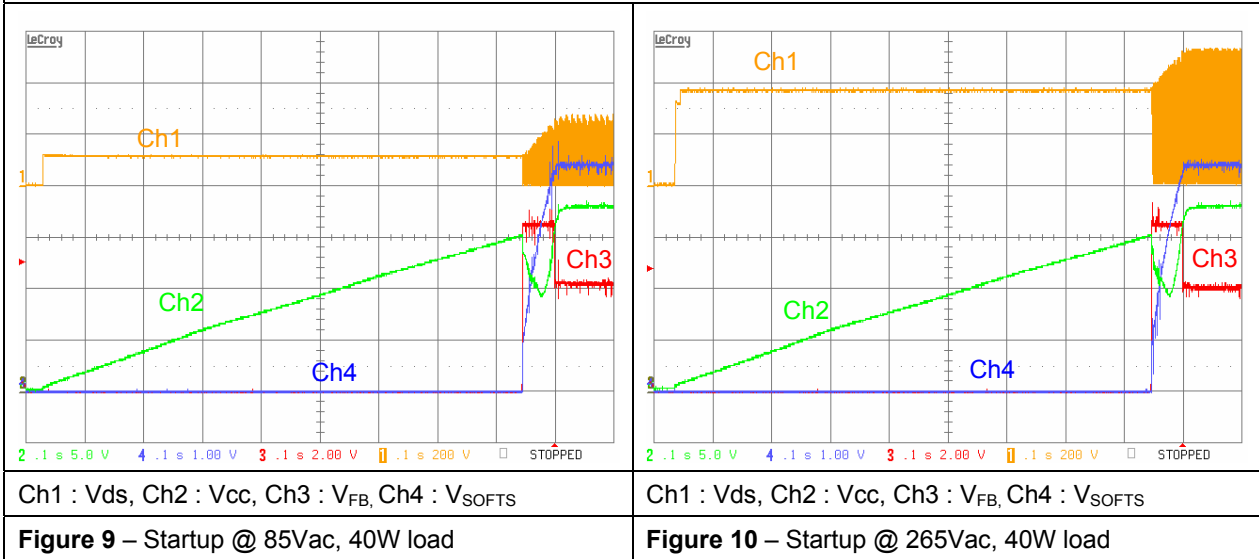

Figure 8 – Input Standby Power @ no load and 0.5W load vs. AC Line Input Voltage

10 Test Waveforms

10.1 Start Up (turn on at full load)

Start up time is about 0.7s which is independent of input voltage.



10.2 Active Burst Mode (zero load)

Feedback voltage bounce between 2.8V to 4V during burst mode.

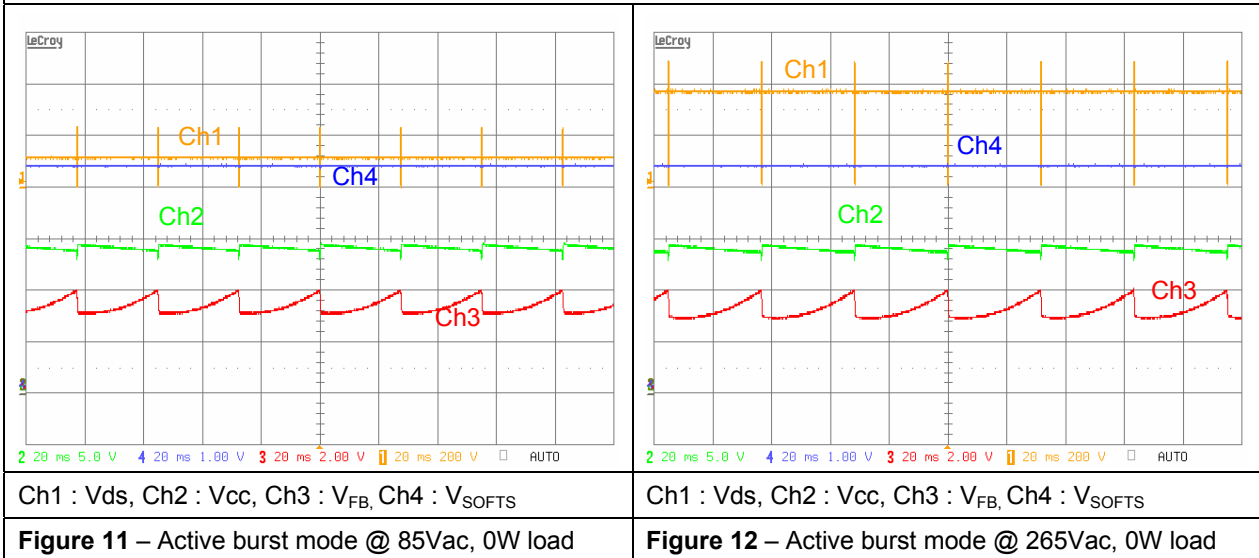

10.3 Enter active burst mode (full load to zero load)

As Vfb went below 1.3V and right after the blanking period, i.e. Vsofts charge from 4.4V to 5.4V, controller enters active burst mode. The blanking period here is to prevent false triggering of burst mode. The blanking time is around 32ms.

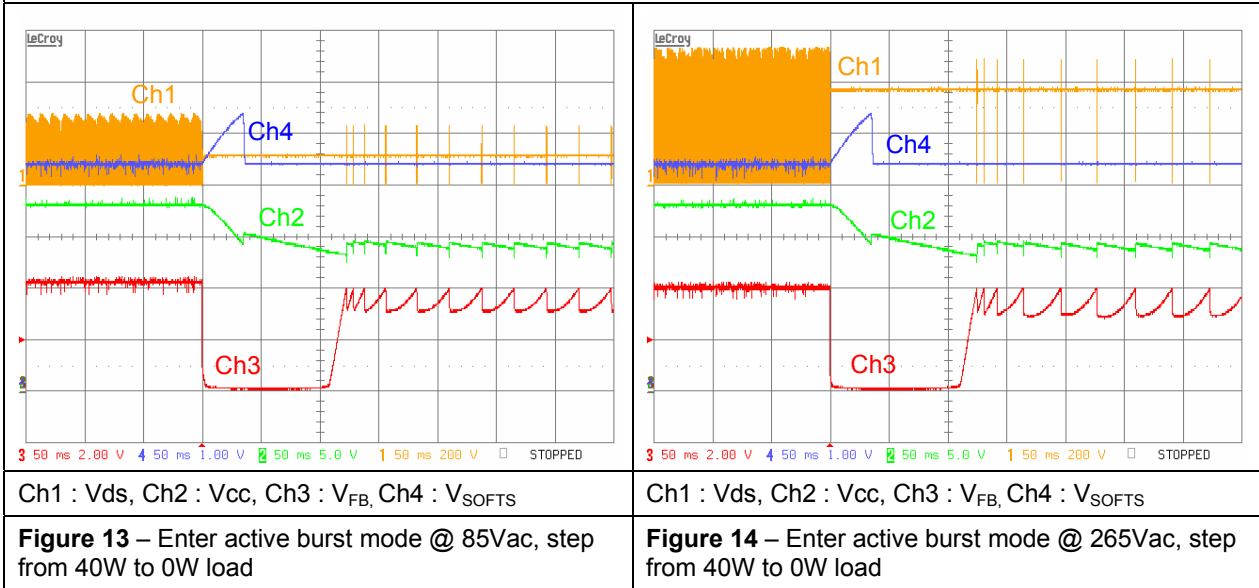

10.4 Leave active burst mode to normal mode (zero load to full load)

Controller returns to normal mode once Vfb hit 4.8V.

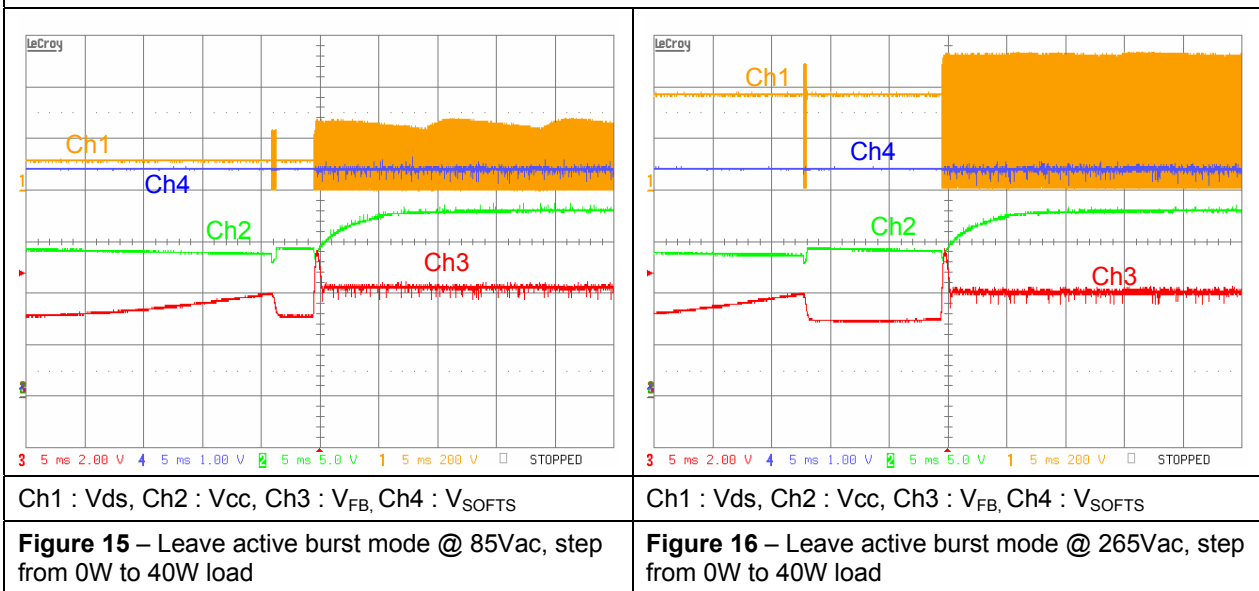

10.5 Short circuit protection (short at full load)

During output short circuit, the FB voltage $> 4.8V$. The SOFTS pin start to charge from 4.4V to 5.4V. When it hits 5.4V, the controller enters auto-restart mode. The blanking time is around 34ms.

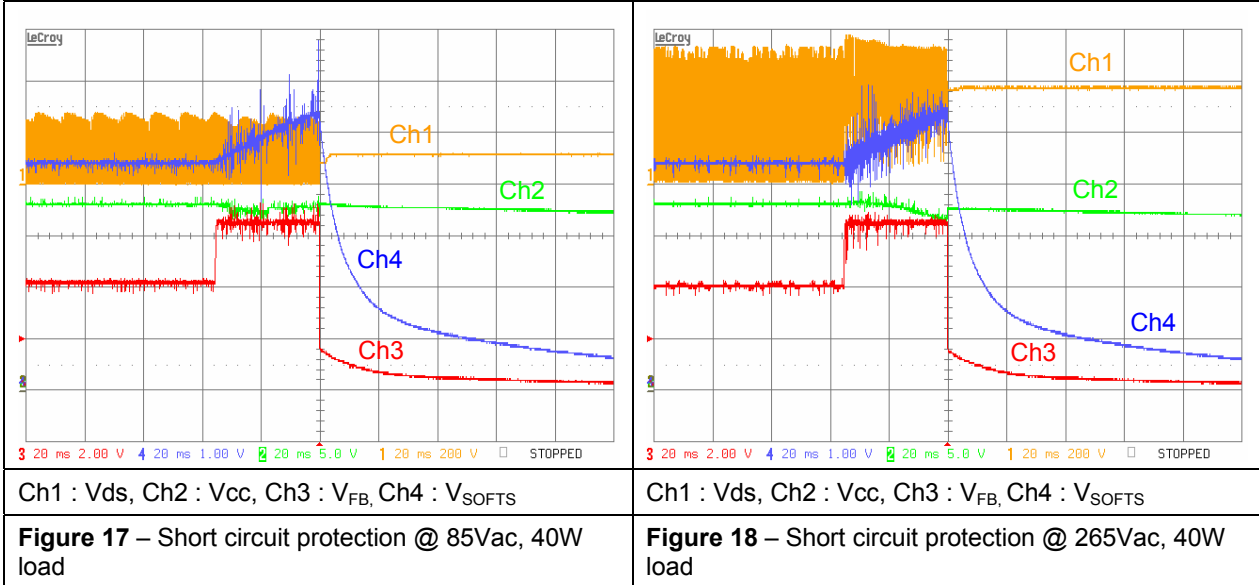

10.6 Vcc overvoltage protection (turn on at zero load while loop opened)

When Vcc is greater than 17V while Vsofts is less than 4V during start up, the controller enter Vcc overvoltage protection, i.e. auto-restart.

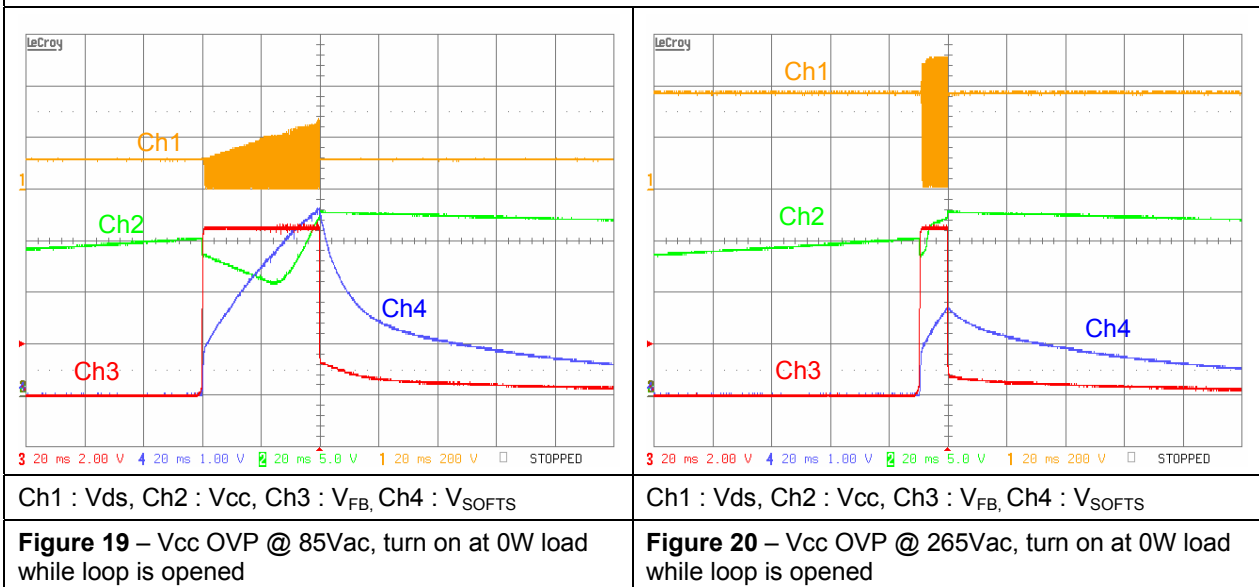

10.7 Open loop protection (turn on at full load while loop opened)

If V_{fb} is found greater than 4.8V, V_{softs} starts to charge up from 4.4V to 5.4V. Once V_{softs} reaches 5.4V, the controller enters auto-restart mode.

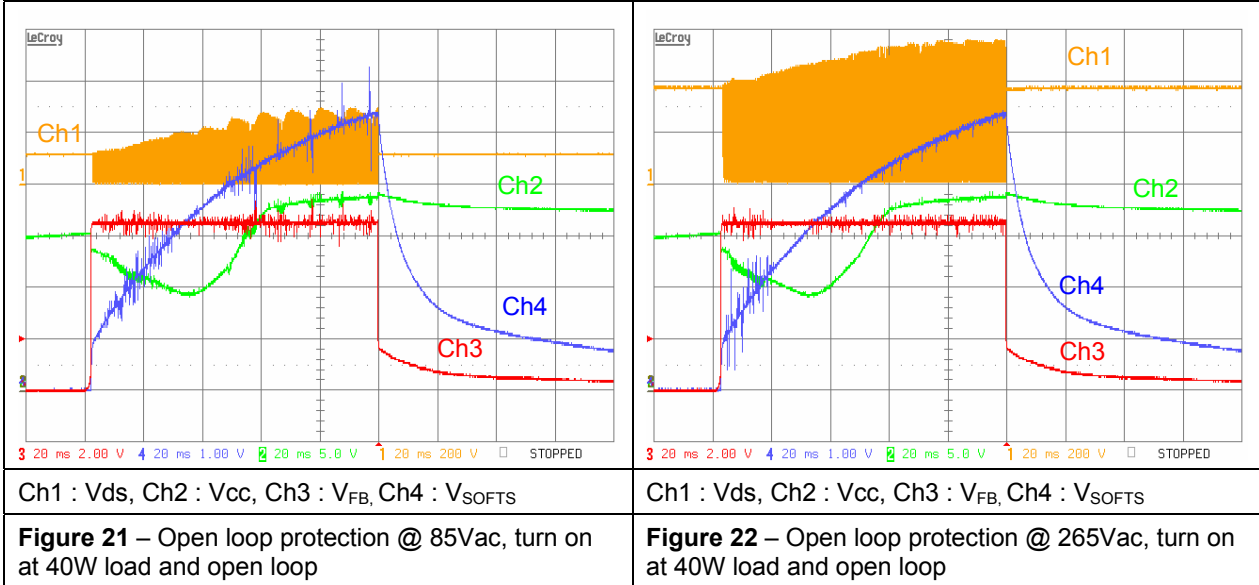

10.8 Over Load Protection (load jump from 2.22A to 4A)

When the loading step from 2.22A to 4A, the FB voltage will be larger than 4.8V. Then the SOFTS pin starts to charge from 4.4V to 5.4V. When it reaches 5.4V, the controller enters auto-restart mode. The blanking window (SOFTS pin charge up time from 4.4V to 5.4V) is around 32ms.

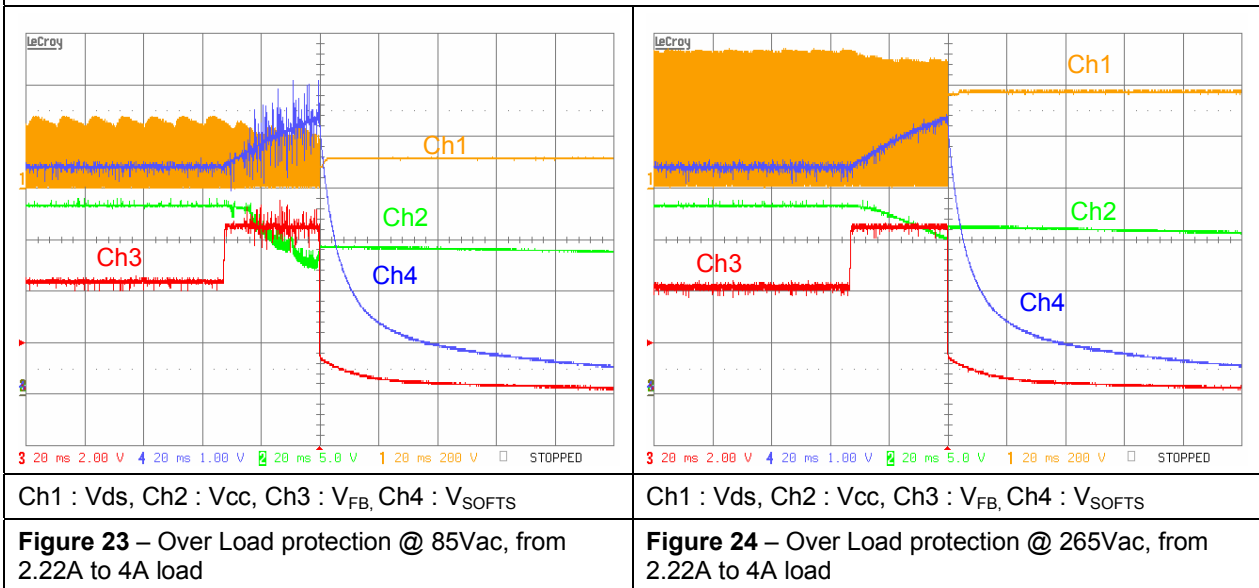

11 Reference

- [1] **Infineon Technologies**, Datasheet
CoolSET™ – F3 OFF-Line SMPS Current Mode Controller with integrated 650V Startup Cell / CoolMOS™
- [2] **Infineon Technologies**, Application Note
AN-SMPS-ICE2AXXXX-1 CoolSET™ ICE2AxXXX for OFF-Line Switch Mode Power Supply (SMPS)
- [3] **Infineon Technologies**, Application Note
AN-SMPS-ICE3DS01-1 CoolSET™ ICE3DS01 Current Mode Controller for OFF-Line Switch Mode Power Supply (SMPS)
- [4] **APEB Power Management Chapter September**, Article 60W SMPS design achieving <100mW standby power.