



2 Pad Metal Package, 4.7 mm x 13.3 mm



HC49USM Series

Product Features:

- Low Cost SMD Package
- Low ESR
- Compatible with Lead free Processing

Applications:

- Fibre Channel
- Server & Storage
- Sonet /SDH
- 802.11 / Wifi
- T1/E1, T3/E3
- System Clock

Frequency	3.2 MHz to 100.000 MHz
ESR (Equivalent Series Resistance)	
3.2 MHz – 3.49 MHz	300 Ω Max.
3.5 MHz – 3.99 MHz	200 Ω Max.
4.0 MHz – 4.99 MHz	150 Ω Max.
5.0 MHz – 5.99 MHz	120 Ω Max.
6.0 MHz – 6.99 MHz	100 Ω Max.
7.0 MHz – 8.9 MHz	80 Ω Max.
9.0 MHz – 12.9 MHz	60 Ω Max.
13 MHz – 19.9 MHz	40 Ω Max.
20 MHz – 36 MHz	30 Ω Max.
27 MHz – 100 MHz (3 rd O.T.)	100 Ω Max.
Shunt Capacitance (C0)	7 pF Max.
Frequency Tolerance @ 25° C	±30 ppm Standard (see Part Number Guide for more options)
Frequency Stability over Temperature	±50 ppm Standard (see Part Number Guide for more options)
Crystal Cut	AT Cut Standard
Load Capacitance	18 pF Standard (see Part Number Guide for more options)
Drive Level	1 mW Max.
Aging	±5 ppm Max. / Year Standard
Temperature	
Operating	0° C to +70° C Standard (see Part Number Guide for more options)
Storage	-40° C to +85° C Standard

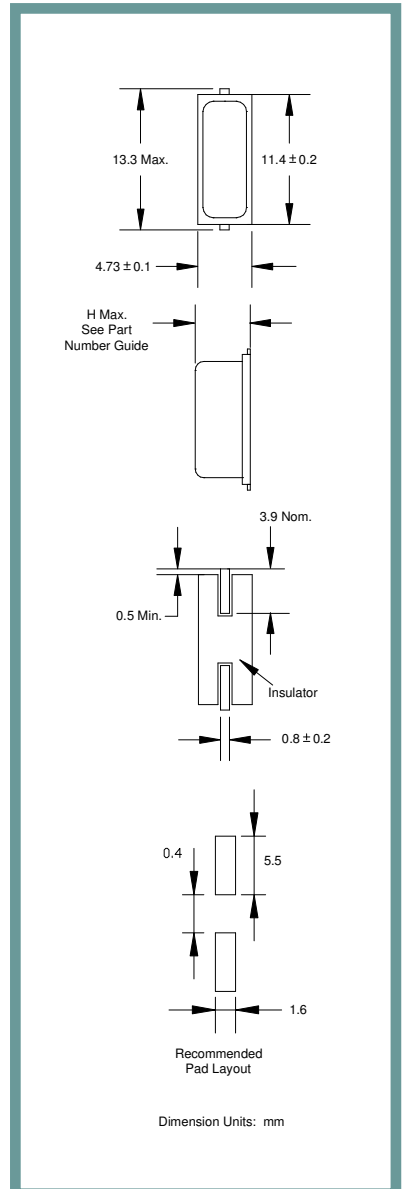

Part Number Guide		Sample Part Number: HC49USM – FB1F18 - 20.000				
Package	Tolerance (ppm) at Room Temperature	Stability (ppm) over Operating Temperature	Operating Temperature Range	Mode (overtone)	Load Capacitance (pF)	Frequency
HC49USM - (4.5 mm H)	B = ±50 ppm	B = ±50 ppm	0 = 0°C to +50°C	F = Fundamental	18 pF Standard or Specify	- 20.000 MHz
HC49USM2 - (3.5 mm H)	F = ±30 ppm	F = ±30 ppm	1 = 0°C to +70°C	3 = 3 rd overtone		
HC49USM3 - (3.1 mm H)	G = ±25 ppm	G = ±25 ppm	2 = -10°C to +60°C			
	H = ±20 ppm	H = ±20 ppm	3 = -20°C to +70°C			
	I = ±15 ppm	I = ±15 ppm	5 = -40°C to +85°C			
	J = ±10 ppm	J = ±10 ppm	9 = -10°C to +50°C			



2 Pad Metal Package, 4.7 mm x 13.3 mm



HC49USM Series

Pb Free Solder Reflow Profile:

Typical Circuit:

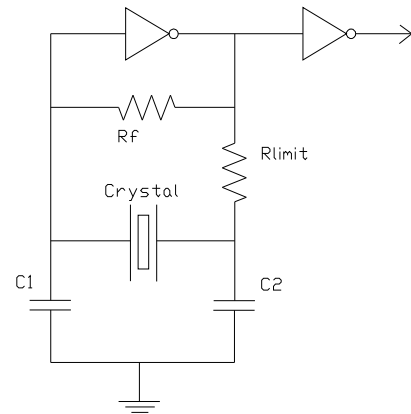
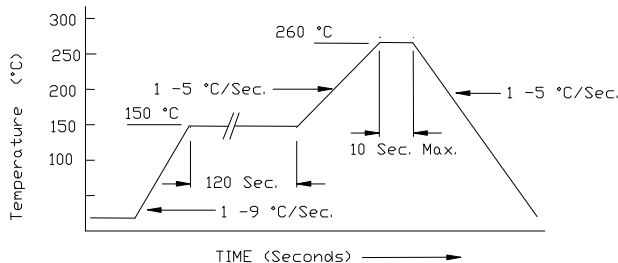

*Units are backward compatible with 240C reflow processes

Package Information:

MSL = N/A
Termination = e1 (Sn / Cu / Ag over Ni over Kovar base metal).

Tape and Reel Information:

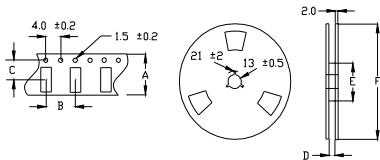

Quantity per Reel	1000
A	24 +/- .3
B	12 +/- .2
C	11.5 +/- .2
D	25 +/- 1.5
E	80/100
F	330

Environmental Specifications

Thermal Shock	MIL-STD-883, Method 1011, Condition A
Moisture Resistance	MIL-STD-883, Method 1004
Mechanical Shock	MIL-STD-883, Method 2002, Condition B
Mechanical Vibration	MIL-STD-883, Method 2007, Condition A
Resistance to Soldering Heat	J-STD-020C, Table 5-2 Pb-free devices (except 2 cycles max)
Hazardous Substance	Pb-Free / RoHS / Green Compliant
Solderability	JESD22-B102-D Method 2 (Preconditioning E)
Terminal Strength	MIL-STD-883, Method 2004, Test Condition D
Gross Leak	MIL-STD-883, Method 1014, Condition C
Fine Leak	MIL-STD-883, Method 1014, Condition A2, R1=2x10 ⁻⁸ atm cc/s
Solvent Resistance	MIL-STD-202, Method 215

Marking

Line 1: ILSI, Frequency, Date Code