

High Life Cycle Interface Connectors

3800 Series

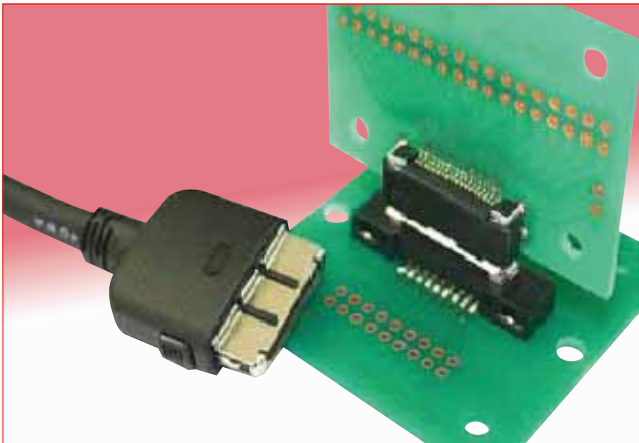

Hirose's Unique Contact Structure with High Durability

- 1) Minimum contact shaving due to a rolled surface on the bellows contact side
- 2) The spring contact design prevents buckling.
- 3) Stable contact design provides the support needed to endure 20,000 mating cycles
Provides ideal long term contact force.

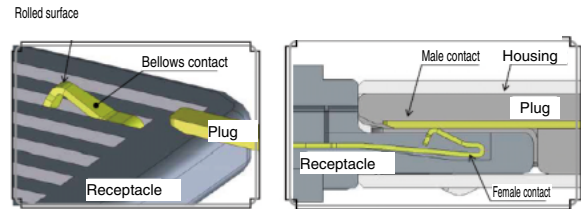

Fig.①

■ Features

1. 20,000 mating/unmating life cycle with unique Hirose contact structure.

2. The structure utilizes a metal shell that is 0.35 mm thick. The shell is designed to cover the housing and protect against rough mechanical operation.

The addition of reinforced metal fittings increases the PCB retention force and allows these connectors to be mounted with commercially available screws for the cradle type. (Fig.②)

3. Sequential mating, that features a 0.5 mm range (Fig.③)

4. Its small size and light weight design are helpful for use in compact devices

5. Simple mating process with a tactile click that assures proper mating completion.

The pushbutton locking system leads to a simplified mating process that delivers a tactile click to ensure that the mating process was correctly completed.

6. One piece plug cover

The assembly of this connector is simplified due to its one-piece plug cover.

7. RoHS compliant

All materials and substances used to produce this product comply with the RoHS free standards.

Robust Structure

- 1) The 0.35 mm thick metal shell protects the housing.

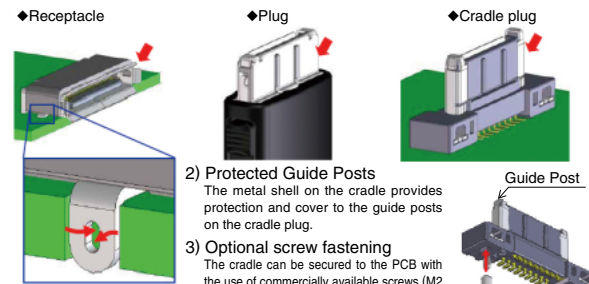

- 2) Reinforcing metal fittings
Solder is allowed to flow into the through hole and onto the reinforcing metal fittings to increase the PCB retention force.

Fig.②

Sequential Mating Structure

The No.1 and 18 contacts are the first contacts to mate, with the remaining contacts mating thereafter.

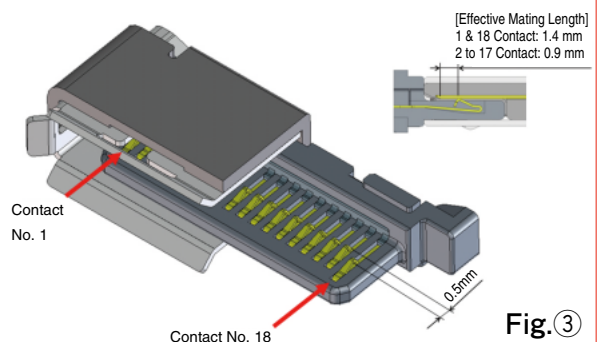

Fig.③

Product Specifications

Ratings	Rated Current	No.2 ~ No.17 ⇒ 0.5A No.1, No.18 ⇒ 1.5A	Rated Voltage	AC 125V
			Operating Temperature Range	

Items	Specifications	Conditions
1. Insulation Resistance	Minimum of 1,000MΩ	Measured with DC 250V.
2. Withstanding Voltage	No flashover or breakdown	Apply 350V AC for 1 minute
3. Contact Resistance	Maximum of 70mΩ	Measured with 100mA (DC or 1,000 Hz) or below
4. Durability	1) Maximum of 20mΩ of deflection from its initial state 2) No damaged, cracked or loose parts	20,000 mating cycles

Materials / Finish

Receptacle

Component	Materials	Color/Finish	Remarks
Housing	Polyamide resin	Black	UL94V-0
Contact	Copper alloy	Selective gold plating	-
Dust cover	Polyamide resin	Black	UL94V-0
Metal shell	Stainless Steel	Tin plating	-

Cradle Type Plug

Component	Materials	Color/Finish	Remarks
Housing	Polyamide resin	Black	UL94V-0
Contact	Copper alloy	Selective gold plating	-
Metal shell	Stainless steel	Tin plating	-
Fastening screw metal	Steel	Nickel under plating	-

Plug

Component	Materials	Color/Finish	Remarks
Housing	Polyamide resin	Black	UL94V-0
Contact	Copper alloy	Selective gold plating	-
Cover	Polycarbonate	Black	UL94V-0
Metal shell	Stainless steel	-	-

Product Number Structure

Refer to the chart below when determining the product specifications from the product number.
Please select from the product numbers listed in this catalog when placing orders.

38 40 - B - 18 P
① ② ③ ④ ⑤

① Series Number : 38	③ Mating Key Type
② Termination style 40 : Soldering Type 60 : Right Angle SMT Type 80 : Cradle Type SMT Type	④ No. of Contacts
	⑤ Type of Connector P : Plug S : Receptacle

Receptacle Connector



Part No.	HRS No.	Quantity
3860-B-18S	238-2006-7 00	600 pcs/reel

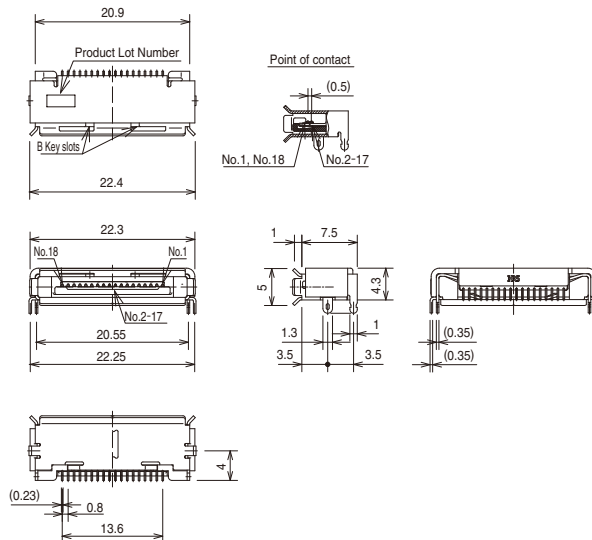

Cradle Plug Connector

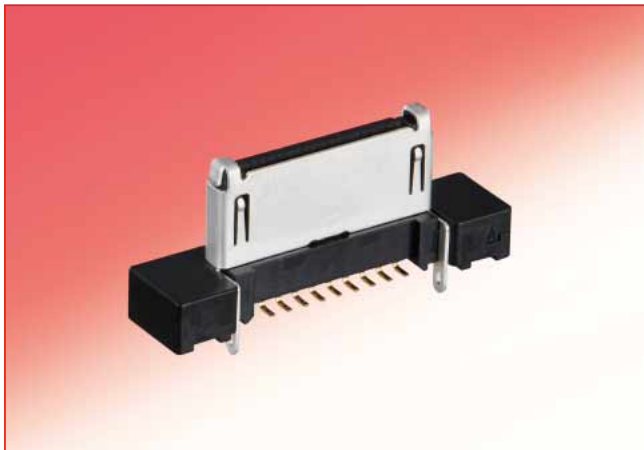

Part No.	HRS No.
3880-B-18P	238-2008-2 00

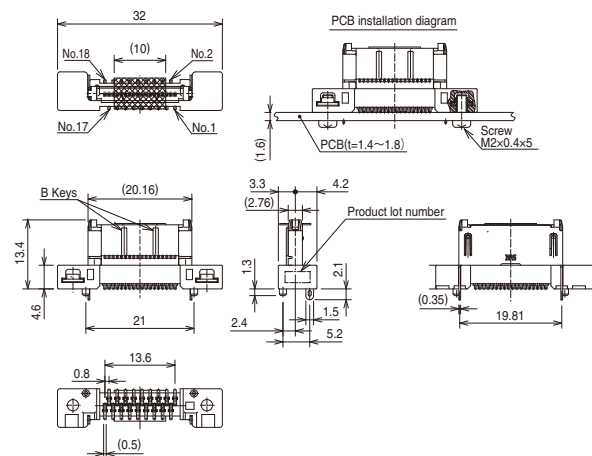

Plug Connector



Part No.	HRS No.
3840-B-18P	238-2007-0 00

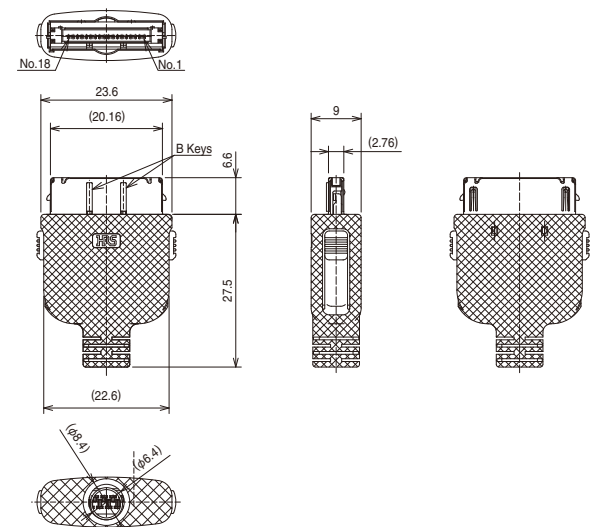

Apr. 1. 2020 Copyright 2020 HIROSE ELECTRIC CO., LTD. All Rights Reserved.

◆ Applicable Cable

Conductor Size	Cross Section	0.08mm ²
	Configuration	7 / 0.127mm
	Outer Diameter	φ0.38mm
Outer Diameter of Insulation	φ0.58mm	
Wire Size	28 AWG	

UL STYLE OF APPLICABLE CABLE : 20620、20276

◆ Recommended PCB Layout

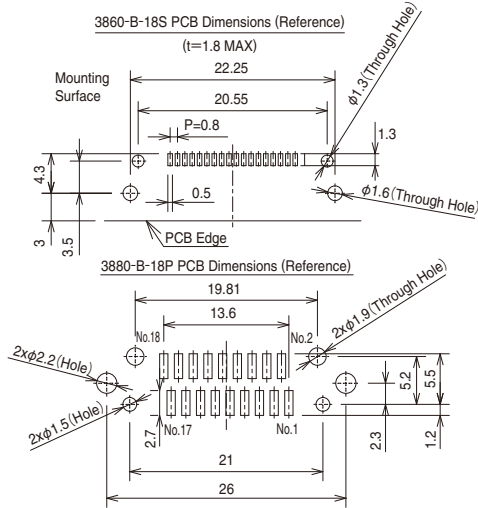

◆ Receptacle Reel packaging dimensions (JIS C 0806-3)

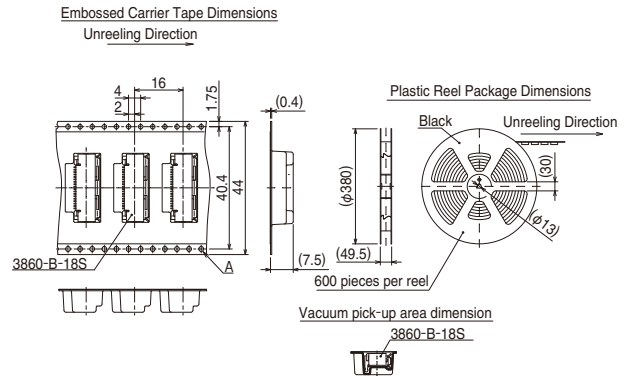

◆ Recommended Reflow Temperature Profile

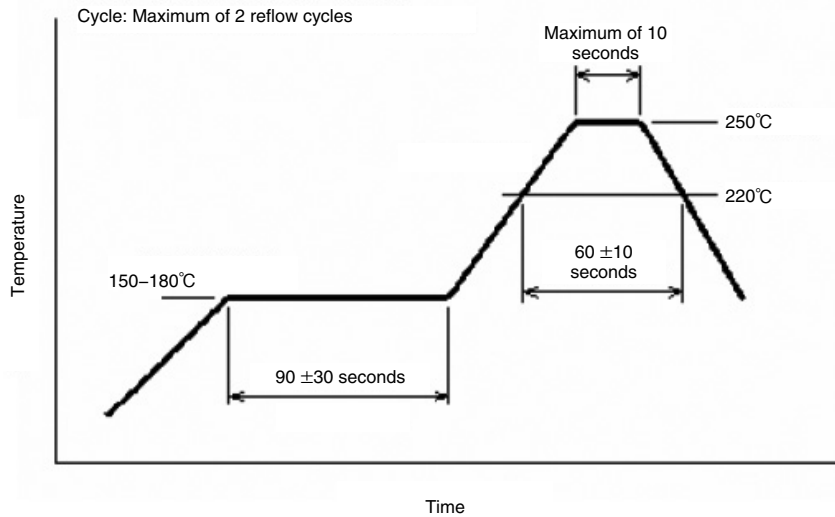

Please check the mounting conditions before use, conditions such as solder paste types, manufacturer, PCB size and any other soldering materials may alter the performance of such materials.



HIROSE ELECTRIC CO.,LTD.

2-6-3,Nakagawa Chuoh,Tsuzuki-Ku,Yokohama-Shi 224-8540,JAPAN

TEL: +81-45-620-3526 Fax: +81-45-591-3726

<http://www.hirose.com>

<http://www.hirose-connectors.com>