

A	9.70±0.5
B	12.9±0.5
D	12.80±0.5
E	6.70±0.2
F	3.00±0.2
G	7.00±0.1
I	11.20±0.5
T	0.50±0.04
CageHRC38-42	

1. Cage 50C NutSAF1010

Small technical drawing of a nut with a callout '10-32' pointing to the thread.

NOTES:

- 1) Screw Material: Low Carbon Steel
- 2) Screw Finish: Black Oxide
- 3) Washer Material: Black Nylon 6/6
- 4) Washer Outside Diameter: 0.429"-0.439"
- 5) Washer Thickness: 0.030"-0.040"
- 6) Must Be Heat Treated To ANSI B18.6.3 Spec
- 7) Must Be RoHS And Reach Compliant

REV	DESCRIPTION	DATE	DRAWN	CHECKED

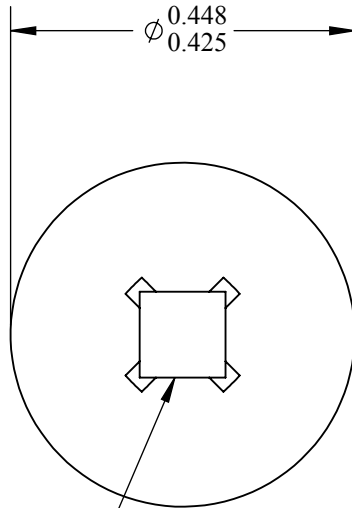
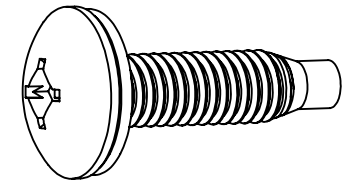

#2R Type-III Square Recess
Penetration Gaging Depth: 0.060"-0.075"
#2 Type-I Phillips Cross Recess
Penetration Gaging Depth: 0.070"-0.093"

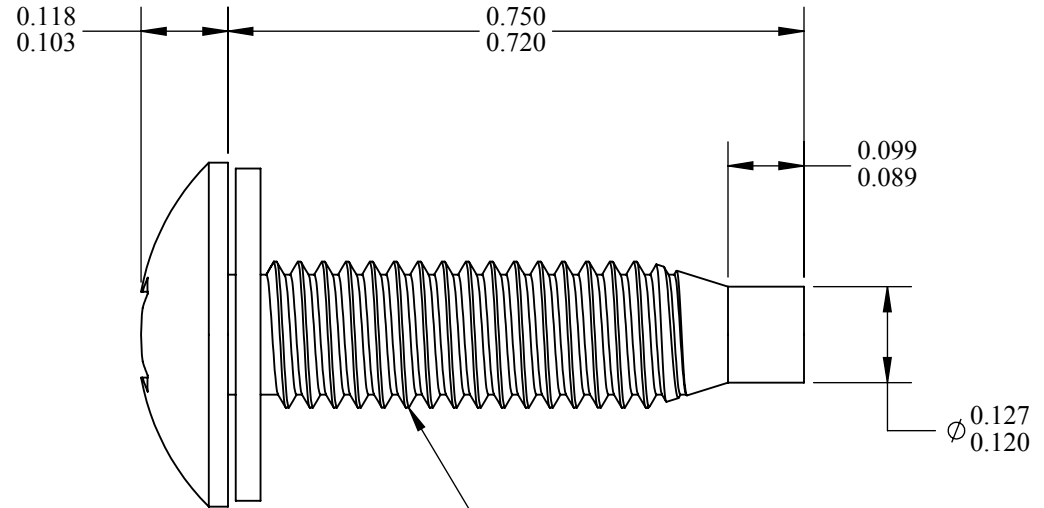

10-32 UNF-2A Thread

CUSTOMER SIGNATURE REQUIRED

NAME		DATE		INTERPRET GEOMETRIC TOLERANCING PER:		TITLE: 10-32x3/4" Quadrex Truss Head Machine Screw Full Dog Point With Captive Flat Washer				 a WOLSELEY Industrial Group company				
ENDRIES DRAWN	JJW	8/28/15		UNLESS OTHERWISE SPECIFIED: DIMENSIONS ARE IN INCHES TOLERANCES: FRACTIONAL ± ANGULAR: MACH ± BEND ± TWO PLACE DECIMAL ± THREE PLACE DECIMAL ±								MATERIAL		FINISH
ENDRIES CHECKED	KDB	8/28/15		PROPRIETARY AND CONFIDENTIAL THE INFORMATION CONTAINED IN THIS DRAWING IS THE SOLE PROPERTY OF ENDRIES INTERNATIONAL. ANY REPRODUCTION IN PART OR AS A WHOLE WITHOUT THE PERMISSION OF ENDRIES INTERNATIONAL IS PROHIBITED.		See Notes		See Notes			SCS19544QUAD	A		
CUSTOMER SIGNATURE:				DO NOT SCALE DRAWING		SHEET: 1 of 1		UNSPECIFIED DIMENSIONS AND TOLERANCES PER:				WEIGHT:	SCALE:4:1	A
								ASME B18.6.3						