

## PULSE TRANSFORMERS

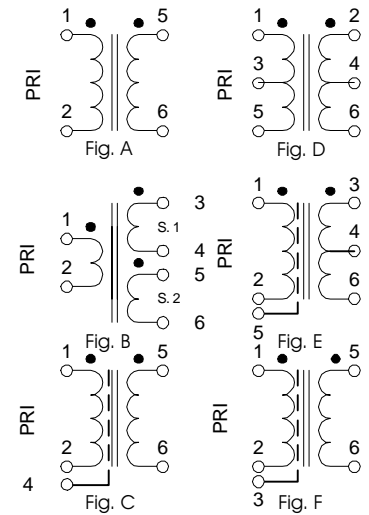

- These ferrite cored transformers are fully encapsulated in a high grade black molded case with a UL94V-O rating.
- Units are intended for wide band and pulse applications including thyristor / triac firing circuits, signal isolation, line matching, low power switch mode power supplies, etc.
- Working voltage rating maximum of 500V RMS
- All units are voltage proof tested to 2.0KV peak 50 Hz.

Cat. No.	Ratio	Primary		Leakage Inductance uH (max)	Capacity pf. (max)	D.C. Winding Resistance (ohms)			Sch. Fig. #	Remarks
		Inductance mH (min)	ET Constant V (uS)			Pri.	Sec. 1	Sec. 2		
610AA	1:1	3	200	22	23	1.2	1	-	A	-
610BB	1:1:1	3	200	9	28	1.4	1.3	1.7	B	-
610C	2:1:1	12	400	35	30	4	1.8	2.4	B	-
610D	1:1 & Shld	3	200	32	15	1.3	1	-	C	610AA plus electrostatic shield
610E	1:1:1	22	550	85	18	10.6	8.9	12.2	B	-
610F	1 ct: 1 ct	3	200	22	23	1.2	1	-	D	610AA with center taps
610G	1:1 ct & Shld	12	400	100	11	3.8	5.3	-	E	includes electrostatic shield
610H	1:2 ct & Shld	1.5	140	15	15	1.2	2.6	-	F	includes electrostatic shield

## PULSE TRANSFORMERS

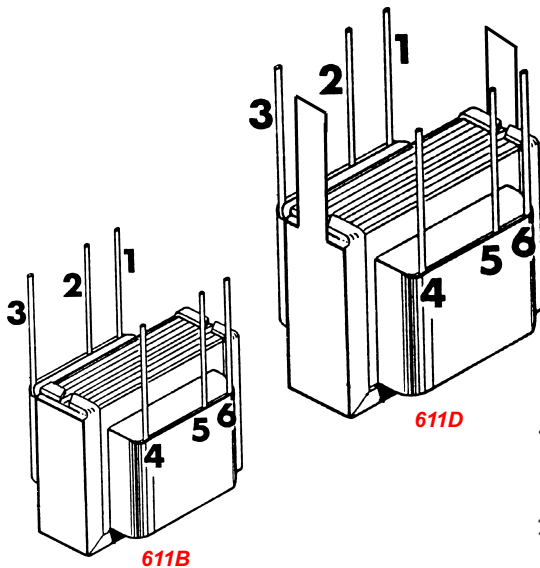

- Economical, open style, P. C. board pin mount
- Units are intended for pulse applications including thyristor / triac firing circuits.

Cat. No.	Ratio	Circuit Max. Volts	Primary		D.C. Winding Resistance		Insulation RMS (Volts)	Wt. Oz.
			Inductance mH (min)	D.C. Res. (Ohms)	Sec. 1 (Ohms)	Sec. 2 (Ohms)		
611A	1:1	125	8.6	0.45	0.55	-	1000	0.7
611B	1:1:1	125	17.2	1.26	1.0	1.53	1000	0.7
611C	1:1	250	56	3.31	4.46	-	1500	1.2
611D	1:1:1	250	17	1.73	1.31	2.12	1500	1.2

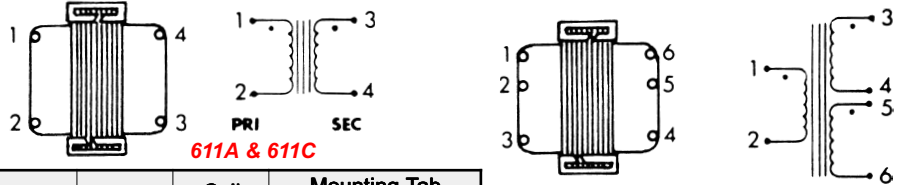

Cat. No.	Pin Spacing	Height	Width	Coil Depth	Mounting Tab	
					Centers	Size
611A & 611B	0.2" x 0.6"	.69"	.82"	.57"	-	-
611C & 611D	0.2" x 0.6"	.82"	1.06"	.82"	1"	.12" x .25"

Pulse

CANADA

Phone: (519) 822-2960 Fax: (519) 822-0715

USA

Phone: (716) 651-0086 Fax: (716) 651-0726



© 2000

**HAMMOND MANUFACTURING™**  
www.hammondmfg.com