

Features

Auto/Off/On output module 10 A

- Auto/Off/On output module intended to permit the automatic control of pumps, blowers or motor groups. Or, in the case of installation, maintenance or failure, to permit the load equipment to be turned "Off" or controlled under "On" control
- Ideal interface for PLC and electronic systems
- Only 11.2 mm wide
- 3 function selector switch:
 - Auto: works as a monostable relay (following A3 input)
 - Off: relay permanently OFF
 - On: relay permanently ON
- 24V AC/DC supply and module input
- 35 mm rail (EN 60715) mounting

Application examples:

- control of pumps, blowers or motor groups
- primarily suited to Industrial control systems

Wiring diagram

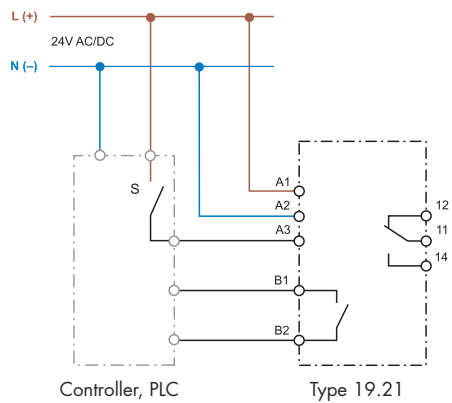

For outline drawing see page 11

19.21.0.024.0000



- 1 CO output contact
- 11.2 mm wide
- Feedback contact

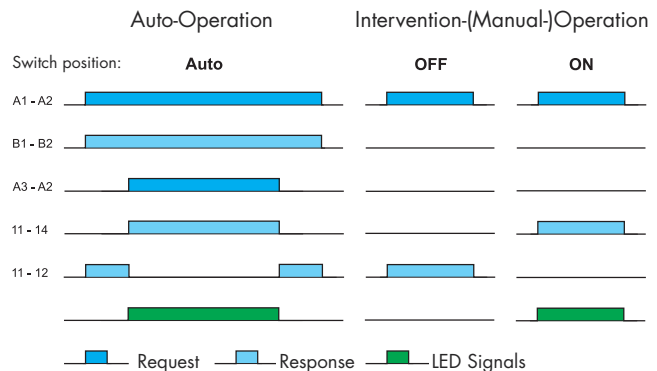

B1-B2 feed back information to the controller for Auto-operation
A3-A2 From the controller requested operation

Contact specification		
Contact configuration		1 CO (SPDT)
Rated current/Maximum peak current	A	10/15
Rated voltage/Maximum switching voltage V AC		250/400
Rated load AC1	VA	2,500
Rated load AC15 (230 V AC)	VA	500
Single phase motor rating (230 V AC)	kW	0.44
Breaking capacity DC1 (24/110/220 V)	A	10/0.3/0.12
Minimum switching load	mW (V/mA)	300 (5/5)
Standard contact material		AgSnO ₂
Feedback contact specification (terminals B1-B2)		
Contact configuration		1 NO (SPST-NO)
Maximum current	mA	0.3
Rated voltage	V AC/DC	24
Supply & Input specification		
Nominal voltage (U _N)	V AC (50/60 Hz)	24
	V DC	24
Rated power	VA (50 Hz)/W	0.6 (50 Hz)/0.4
Operating range	AC	(0.8...1.1) U _N
	DC	(0.8...1.1) U _N
Technical data		
Ambient temperature range	°C	-20...+50
Protection category		IP 20
Approvals (according to type)		CE PG

Features

1-channel status indicating module

- 1-channel indicating module to provide visual indication of BMS/DDC/PLC input or output status with immediate indication of its importance or urgency according to the colour of the LED. A change-over output contact, following the input to the module, provides for further control or status feedback. Commonly used in building management systems
- 24V AC/DC input
- 35 mm rail (EN 60715) mounting

Application examples:

- status reports of heating installations, pumps, blowers or motor groups
- error reports such as danger of frost or blocked filter
- fire alarm

Wiring diagram

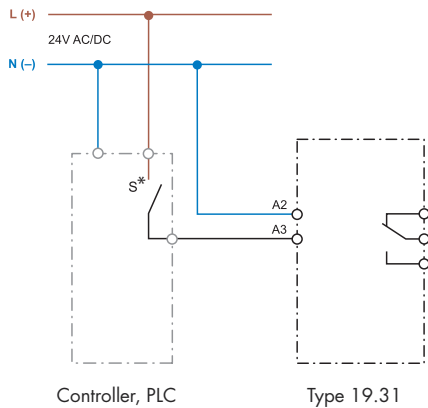

NEW 19.31.0.024.0000



- LED indicator, 3 colours: Red, Green, Blue
- 1 CO control
- 17.5 mm wide

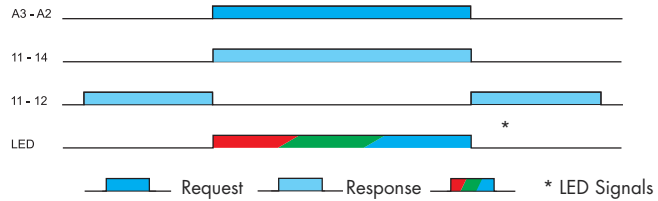
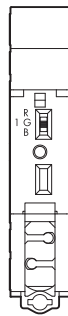

A3-A2 Status signal of the control panel in the case of faulty operation, normal operation or alarm.
 * The LED colour red, green and blue is freely selectable with a switch on the back side for the signal input on A3-A2

The LED colour is selected by the dip-switch on the rear face of the module, prior to mounting on the 35 mm rail.

The colour is determined by the system designer according to the urgency or importance of the signal.

Commonly, the following levels of importance or urgency are assigned to the Red, Green and Blue colours according to EN 60073:

- Red LED: Error
- Green LED: In operation
- Blue LED: Alarm (fire or similar)

For outline drawing see page 11

Contact specification		
Contact configuration		1 CO (SPDT)
Rated current/Maximum peak current	A	1/3
Rated voltage/Maximum switching voltage V AC		125/250
Rated load AC1	VA	125
Rated load AC15 (230 V AC)	VA	25
Single phase motor rating (230 V AC)	kW	—
Breaking capacity DC1 (24/110/220 V)	A	1/0.3/—
Minimum switching load	mW (V/mA)	10 (0.1/1)
Standard contact material		AgNi + Au
Input specification		
Nominal voltage (U _N)	V AC (50/60 Hz)	24
	V DC	24
Rated power	VA (50 Hz)/W	0.4 (50 Hz)/0.25
Operating range	AC	(0.8...1.1) U _N
	DC	(0.8...1.1) U _N
Technical data		
Ambient temperature range	°C	-20...+50
Protection category		IP 20
Approvals (according to type)		

Features

2-channel status indicating module

- 2-channel indicating module to provide visual indication of BMS/DDC/PLC input or output status with immediate indication of its importance or urgency according to the colour of the LED. Two NO output contacts, following the inputs to the module, provide for further control or status feedback. Commonly used in building management systems
- 24V AC/DC inputs
- 35 mm rail (EN 60715) mounting

Application examples:

- status reports of heating installations, pumps, blowers or motor groups
- error reports such as danger of frost or blocked filter
- fire alarm

Wiring diagram

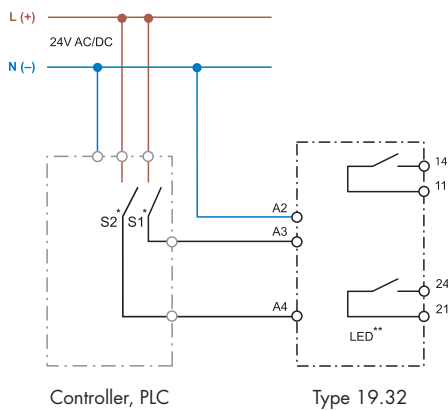

For outline drawing see page 11

Output specification		
Contact configuration		2 NO (SPST-NO) separate output
Rated current/Maximum peak current	A	1/3
Rated voltage/Maximum switching voltage V AC		125/250
Rated load AC1	VA	125
Rated load AC15 (230 V AC)	VA	25
Single phase motor rating (230 V AC)	kW	—
Breaking capacity DC1 (24/110/220 V)	A	1/0.3/—
Minimum switching load	mW (V/mA)	10 (0.1/1)
Standard contact material		AgNi + Au
Input specification		
Nominal voltage (U _N)	V AC (50/60 Hz)	24
	V DC	24
Rated power	VA (50 Hz)/W	0.8 (50 Hz)/0.5
Operating range	AC	(0.8...1.1) U _N
	DC	(0.8...1.1) U _N
Technical data		
Ambient temperature range	°C	-20...+50
Protection category		IP 20
Approvals (according to type)		

NEW 19.32.0.024.0000



- LED indicator, 3 colours: Red, Green, Blue
- 2 NO control
- 17.5 mm wide

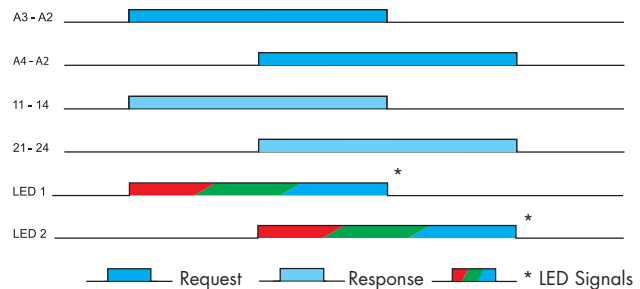
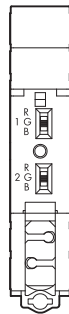

A3-A2 Channel 1: Control signal status
A4-A2 Channel 2: Control signal status

The LED colour is selected by the dip-switch on the rear face of the module, prior to mounting on the 35 mm rail.

The colour is determined by the system designer according to the urgency or importance of the signal.

Commonly, the following levels of importance or urgency are assigned to the Red, Green and Blue colours according to EN 60073:

- Red LED: Error
- Green LED: In operation
- Blue LED: Alarm (fire or similar)

Features

Override module - Auto/Off/Hand

- Auto/Off/Hand override module intended to permit the automatic control of pumps, blowers or motor groups. Or, in the case of installation, maintenance or failure, to permit the load equipment to be turned "Off" or controlled under "Hand" control
- 3 function selector switch:
 - Auto: work as a monostable relay relay (following A3 input)
 - Off: relay output permanently Off
 - Hand: relay output permanently On
- 24V AC/DC supply & input
- 35 mm rail (EN 60715) mounting

Application examples:

- control of pumps, blowers or motor groups commonly associated with building management systems

Wiring diagram

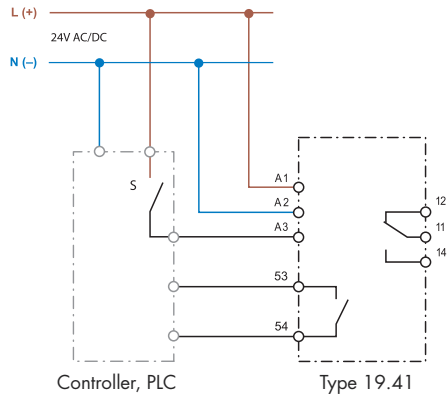

For outline drawing see page 11

NEW 19.41.0.024.0000



- 1 CO output contact
- 1 feedback output contact
- 17.5 mm wide
- LED indicator

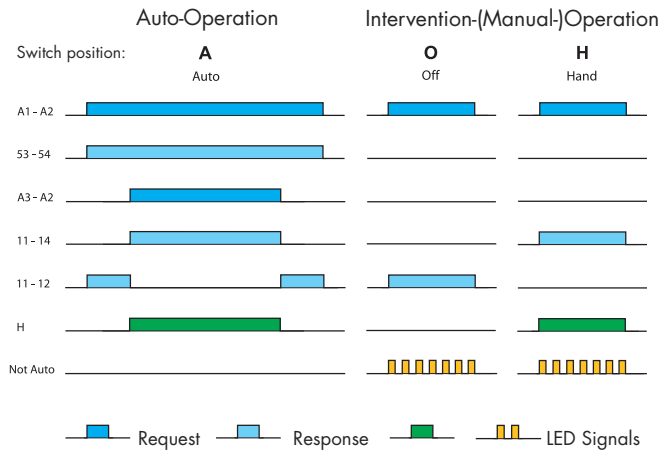

53-54 feed back information to the controller for Auto-operation
A3-A2 Requested operation

Output specification (terminals 12-11-14)		
Contact configuration		1 CO (SPDT)
Rated current/Maximum peak current	A	5/15
Rated voltage/Maximum switching voltage	V AC	250/400
Rated load AC1	VA	1,250
Rated load AC15 (230 V AC)	VA	250
Single phase motor rating (230 V AC)	kW	0.185
Breaking capacity DC1 (24/110/220 V)	A	3/0.35/0.2
Minimum switching load	mW (V/mA)	500 (10/5)
Standard contact material		AgCdO
Feedback output specification (terminals 53-54)		
Contact configuration		1 NO (SPST-NO)
Maximum / Minimum current	mA AC/DC	100/10
Rated voltage	V AC/DC	24
Supply & Input specification		
Nominal voltage (U_N)	V AC (50/60 Hz)	24
	V DC	24
Rated power	VA (50 Hz)/W	1 (50 Hz)/0.6
Operating range	AC	(0.8...1.1) U_N
	DC	(0.8...1.1) U_N
Technical data		
Ambient temperature range		-20...+50
Protection category		IP20
Approvals (according to type)		CE

Features

Override module - Auto/Off/Low/High

- Override output module intended to permit the automatic control of two-speed pumps, blowers or motor groups. Or, in the case of installation, maintenance or failure, to permit the load equipment to be turned "Off" or to run in "Low speed" or "High speed" under "Hand" control
- 4 function selector switch:
 - Auto: directly controlled by the BMS or PLC
 - Off: relays permanently Off
 - Hand Low: Low speed relay output permanently On
 - Hand High: High speed relay output permanently On
- 24V AC/DC supply and module inputs
- 35 mm rail (EN 60715) mounting

Application examples:

- control of two-speed pumps, blowers or motor groups commonly associated with building management systems

Wiring diagram

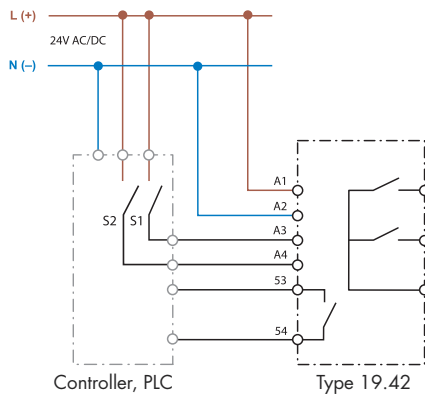

For outline drawing see page 11

NEW 19.42.0.024.0000



- Low and High output contacts
- 1 feedback output contact
- 35 mm wide
- LED indicator

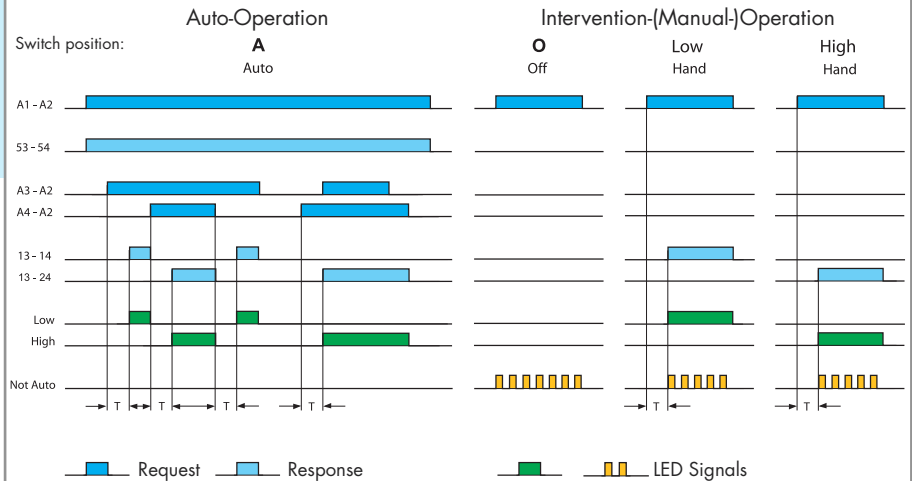

53-54 feed back information to the controller for Auto-operation

A3-A2 Low speed or power operation

A4-A2 High speed or power operation (dominating again low speed or low power operation)

T = ON delay for 13-14 and 13-24 is approx. 100 ms as pause for the speed shift.

By reserving motors with big moments of inertia (inertia force) from high speed to low speed an additional ON delay of approx. 20 s is recommended.

Output specification (terminals 13-14-24)	
Contact configuration	2 NO (DPST-NO)
Rated current/Maximum peak current	A 5/15
Rated voltage/Maximum switching voltage V AC	250/400
Rated load AC1	VA 1,250
Rated load AC15 (230 V AC)	VA 250
Single phase motor rating (230 V AC)	kW 0.185
Breaking capacity DC1 (24/110/220 V)	A 3/0.35/0.2
Minimum switching load	mW (V/mA) 500 (10/5)
Standard contact material	AgCdO
Feedback output specification (terminals 53-54)	
Contact configuration	1 NO (SPST-NO)
Maximum / Minimum current	mA 100/10
Rated voltage	V AC/DC 24
Supply & Input specification	
Nominal voltage (U _N)	V AC (50/60 Hz) 24
	V DC 24
Rated power	VA (50 Hz)/W 1.6 (50 Hz)/0.8
Operating range	AC (0.8...1.1) U _N
	DC (0.8...1.1) U _N
Technical data	
Ambient temperature range	°C -20...+50
Protection category	IP20
Approvals (according to type)	CE

Features

Analogue override module - Auto/Hand (0...10)V

- Analogue output module intended to provide, by the selection switch on the front panel, a (0...10) V output, automatically or by hand. With the selector switch in position "A" (Automatic) the (0...10) V signal is derived from the controller. In position "H" (Hand) the controller signal is ignored and the (0...10) V signal is derived directly from the potentiometer setting on the fascia of the module
- The level of the (0...10) V output signal is displayed by 3 green LEDs, set at >25%, >50% and >75%.
- 24V AC/DC supply
- 35 mm rail (EN 60715) mounting

Application examples:

- permits the direct control of proportional valves under exceptional circumstances or where the automatic controller has failed

Wiring diagram

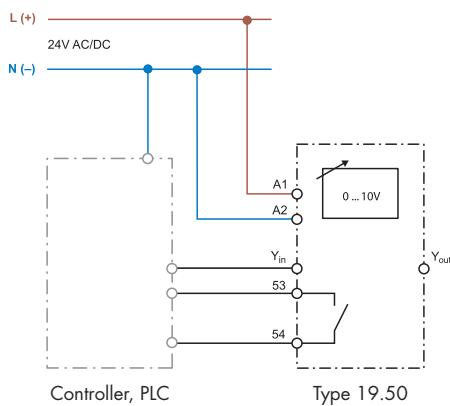

NEW 19.50.0.024.0000



- Analogue output (0...10)V, plus 1 feedback output contact
- 17.5 mm wide
- LED indicator

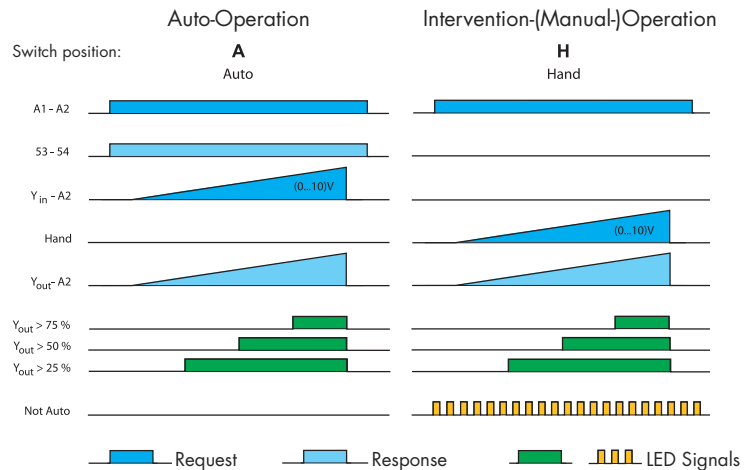

53-54 feed back information to the controller for Auto-operation
 $Y_{in}A2 / \text{Hand} = \text{Set point (set value)} (0...10) \text{ V DC}$;
 requested by the controller or manual

For outline drawing see page 11

(0...10)V Signal specification (terminal Y-in)		
Input control signal	V DC	0...10 (I _{max} 20mA - short-circuit protected)
Green LED 25%		>2.5 V
Green LED 50%		> 5 V
Green LED 75%		>7.5 V
Feedback output specification (terminals 51-52)		
Output configuration		1 NO (SPST-NO)
Maximum / Minimum current	mA	100 / 10
Rated voltage	V AC/DC	24
Supply & Input specification		
Nominal voltage (U _N)	V AC (50/60 Hz)	24
	V DC	24
Rated power AC/DC	VA (50 Hz)/W	0.9 / 0.7
Operating range	AC	(0.8...1.1) U _N
	DC	(0.8...1.1) U _N
Technical data		
Ambient temperature range		-20...+50 °C
Protection category		IP20
Approvals (according to type)		

Features

Power relay module 16 A

- Suitable for Lamps load
- AgSnO₂ contacts for heavy duty, high inrush current loads
- DC supply (12 or 24 V)
- LED indicator
- Reinforced insulation between supply and contacts
- Cadmium Free contacts
- 35 mm rail (EN 60715) mounting

Wiring diagram

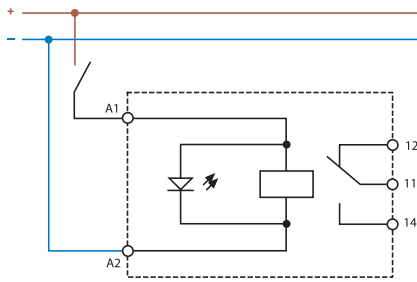

NEW 19.91.9.0xx.4000



- 1 Pole changeover contact
- 17.5 mm

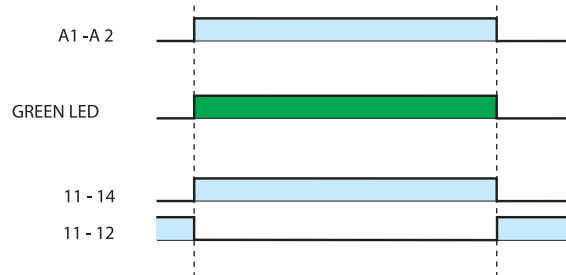

For outline drawing see page 11

Contact specification		
Contact configuration		1 CO (SPDT)
Rated current/Maximum peak current	A	16/30 (120 A – 5 ms)
Rated voltage/Maximum switching voltage	V AC	250/440
Rated load AC1	VA	4,000
Rated load AC15 (230 V AC)	VA	750
Nominal lamp rating (230 V): incandescent	W	2,000
compensated fluorescent	W	750
Minimum switching load	mW	300 (5 V/ 5 mA)
Standard contact material		AgSnO ₂
Coil specification		
Nominal voltage (U _N)	V DC	12 - 24
Rated power AC/DC	VA (50 Hz)/W	1.2 / 0.5
Operating range		(0.8 ... 1.1) U _N
Technical data		
Mechanical life AC/DC	cycles	10 · 10 ⁶
Electrical life at rated load AC1	cycles	80 · 10 ³
Operate/release time	ms	12/8
Ambient temperature range	°C	-20...+50
Protection category		IP 20
Approvals (according to type)		CE

Ordering information

Example: 19 series Auto/Off/Hand override module, 1 CO (SPDT) 5 A contact, 24 V AC/DC supply.

1 9 . 4 1 . 0 . 0 2 4 . 0 0 0 0

Series

Type

- 21= Auto/Off/On output module, 11.2mm
- 31= 1-channel status indicating module
- 32= 2-channel status indicating module
- 41= Override module - Auto/Off/Hand
- 42= Override module - Auto/Off/Low/High
- 50= Analogue override module (0...10) V
- 91= Power relay module

Supply version

- 0 = AC (50/60 Hz) / DC
- 9 = DC

Supply voltage

- 012 = 12 V
- 024 = 24 V

Contact material

- 0= Standard for 19.21/31/32/41/42/50
- 4= Standard for 19.91

Codes / Module width

- 19.21.0.024.0000 / 11.2 mm
- 19.31.0.024.0000 / 17.5 mm
- 19.32.0.024.0000 / 17.5 mm
- 19.41.0.024.0000 / 17.5 mm
- 19.42.0.024.0000 / 35.0 mm
- 19.50.0.024.0000 / 17.5 mm
- 19.91.9.012.4000 / 17.5 mm
- 19.91.9.024.4000 / 17.5 mm

Technical data

Insulation		19.21	19.31/32	19.41/42	19.50	19.91
Dielectric strength (V AC)	between supply and contacts	3,000	1,000	2,000	—	4,000
	between open contacts	1,000	750	1,000	—	1,000
	between supply and feedback output	2,000	—	1,500	1,500	—
EMC specifications						
Type of test		Reference standard	19.21/31/32/42/91		19.41/50	
Electrostatic discharge	contact discharge	EN 61000-4-2	4 kV			
	air discharge	EN 61000-4-2	8 kV			
Radiated electromagnetic field (80 ... 1,000 MHz)		EN 61000-4-3	30 V/m			
Fast transients (burst) (5-50 ns, 5 kHz)		EN 61000-4-4	4 kV			
Voltage pulses (1.2/50 µs)	common mode	EN 61000-4-5	2 kV	1 kV		
	on supply terminals	EN 61000-4-5	1 kV	0.5 kV		
Terminals		19.21		19.31/32/41/42/91		
Screw torque		0.5 Nm		0.8 Nm		
Max. wire size	solid cable	1x6/2x2.5 mm ²	1x10/2x14 AWG	1x6/2 x 4 mm ²	1x10/2x12 AWG	
	stranded cable	1x4/2x1.5 mm ²	1x12/2x16 AWG	1x4/2x2.5 mm ²	1x12/2x14 AWG	
Wire strip length		7 mm		9 mm		

Wiring diagrams - Application examples

Type 19.21

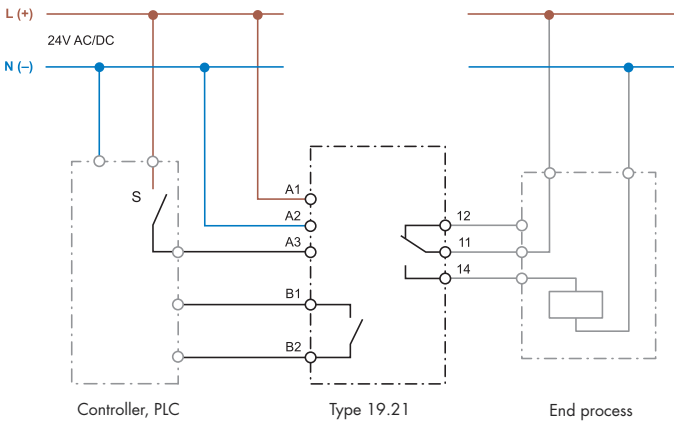

Type 19.31

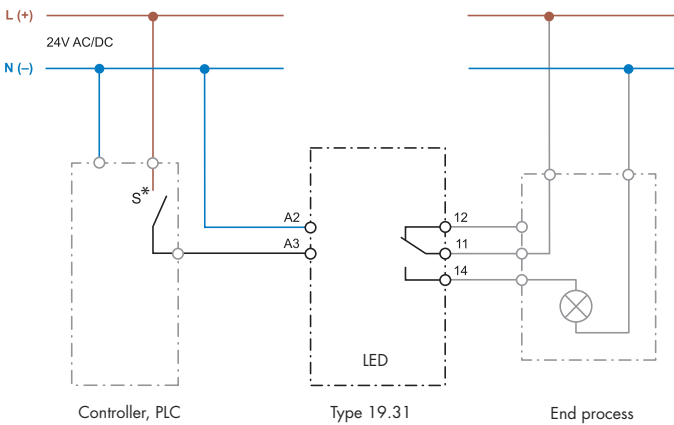

* S can be, for example, a NO-contact with the purpose of indicating "in operation" (selecting green as LED color) or a NC-contact with the purpose of indicating "error" or "alarm" (selecting red or blue as LED color). The LED color has to be chosen through the back side selector.

Type 19.32

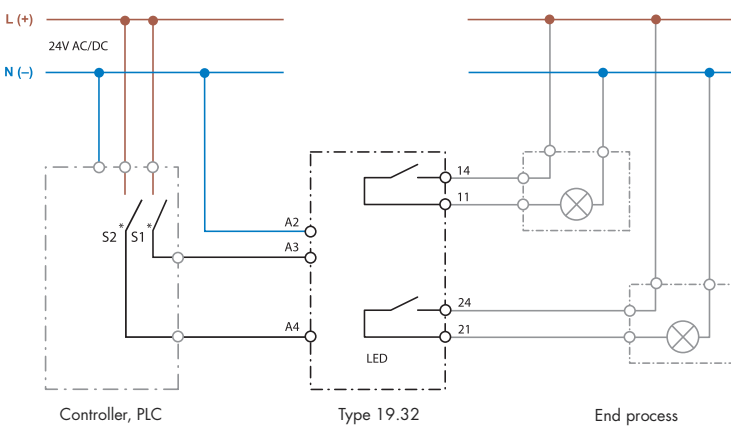

* S1 (related to LED 1 and NO 11-14) and S2 (related to LED 2 and NO 21-24) can be, for example, NO-contacts with the purpose of indicating "in operation" (selecting green as LED color) or NC-contacts with the purpose of indicating "error" or "alarm" (selecting red or blue as LED color). The LED colors have to be chosen, independently, through the back side selectors.

Wiring diagrams - Application examples

Type 19.41

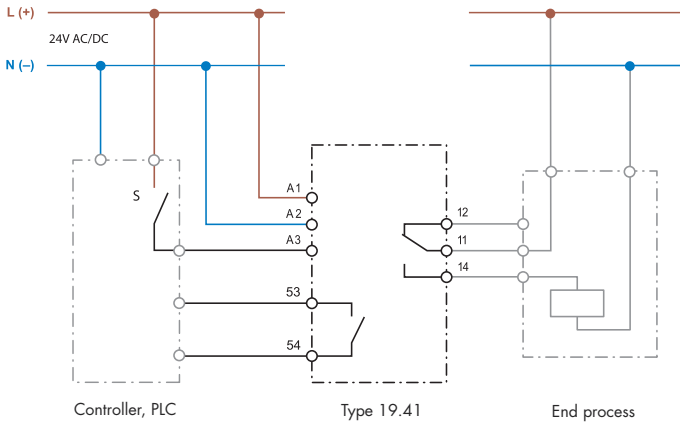

Type 19.42

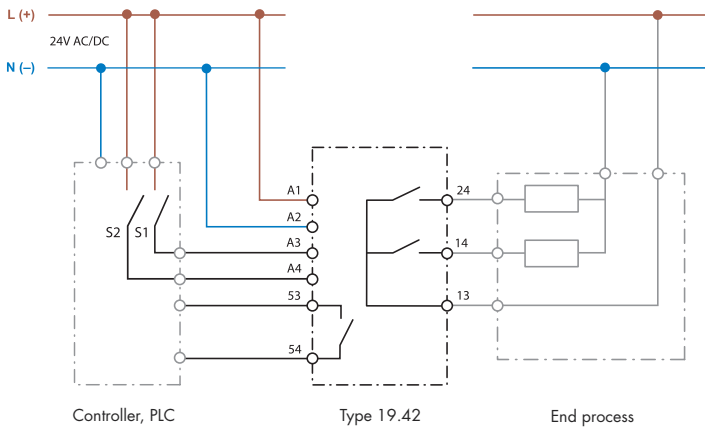

Type 19.50

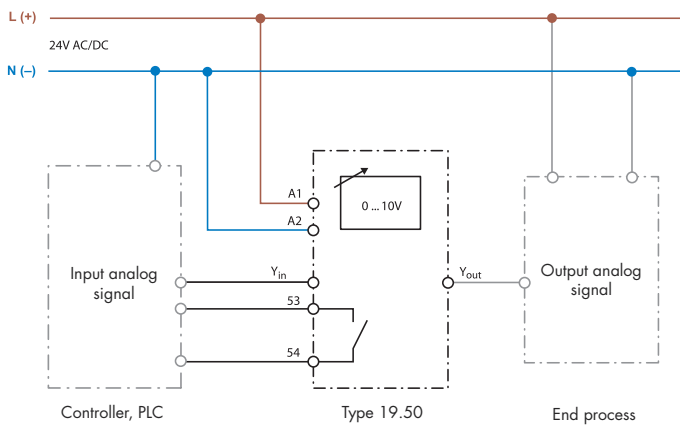

In the selector position A (Automatic) the 0...10 V set point of Y_{in} - A2 is led, through Y_{out}, to the end process;
 in the selector position H (Hand) the 0...10 V value set with the regulator is led, through Y_{out}, to the end process.

Outline drawings

Type 19.21
Screw terminal

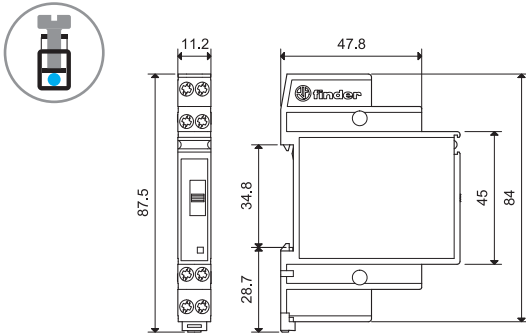

Type 19.31-19.32
Screw terminal

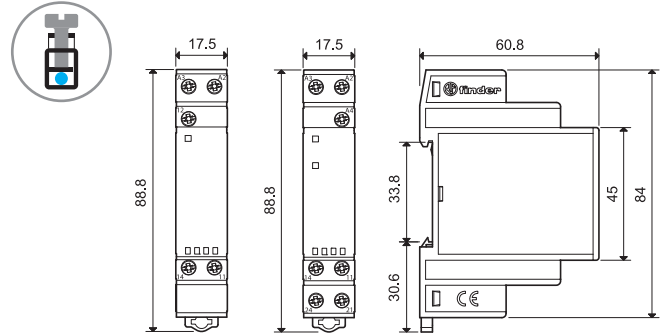

Type 19.41
Screw terminal

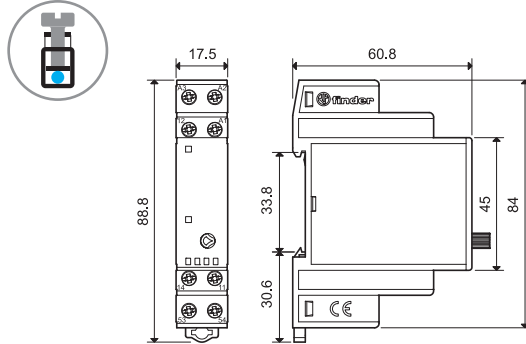

Type 19.42
Screw terminal

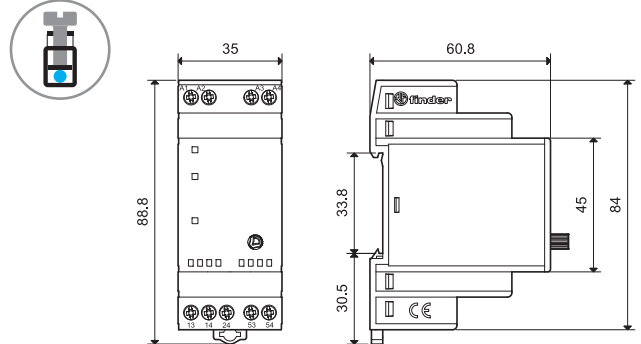

Type 19.50
Screw terminal

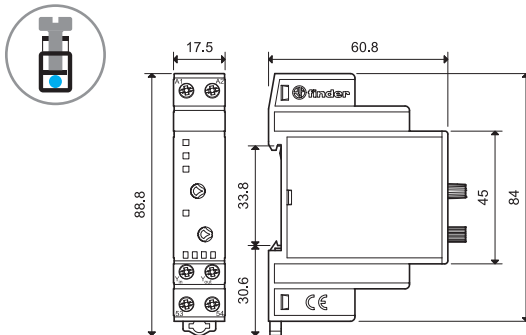

Type 19.91
Screw terminal

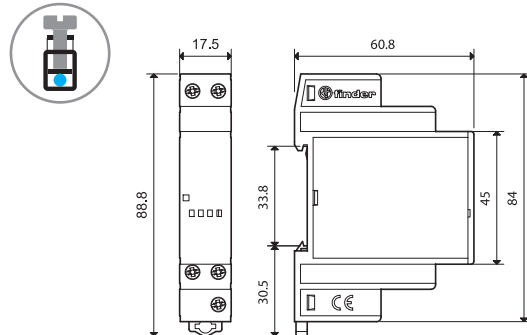

Accessories



019.40

Sheet of marker tags, for 19.21 type, plastic, 40 tags, 8x10 mm

019.40

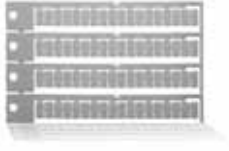

060.72

Sheet of marker tags, for 19.31/32/41/42/50/91 types, plastic, 72 tags, 6x12 mm

060.72



019.01

Identification tag, for 19.31/32/41/42/50 types, plastic, 1 tag, 17x25.5 mm

019.01



020.01

Adaptor for panel mounting, for 19.31/32/41/50/91 types, plastic, 17.5 mm wide

020.01



011.01

Adaptor for panel mounting, for 19.42 type, plastic, 35 mm wide

011.01

Application notes

Intervention Modules

The demand for security apparatus, heating, air conditioning or efficient energy use in offices, hotels, and private homes or in industrial space is growing constantly, leading to the installation of increasingly complex electronic systems. But what happens if these systems malfunction and a qualified service technician will only be available in a few hours, or even days?

With the use of carefully installed intervention modules, a trained caretaker or security guard can be in a position to recognize interruptions in service, and by manual intervention perform the necessary override actions to maintain system operation until a repair can be effected.

Digital Override control module

Auto-Off-On output module (Type 19.21)

Many processes or systems are automatically controlled by an electronic control system or by a Programmable Logic Controller. In the event of an electronic system malfunction it is important, in order to avoid damage or downtime, to plan for the possibility of controlling the process manually. An Auto-Off-On Module can provide this, located between the output of the electronic system (Controller) and the process to be controlled (End Process) - bypassing the malfunctioning control unit in a planned way. For malfunctioning electronic systems, the process to be controlled can be manually switched On or Off, as needed, using the switch on the front of the unit. Under healthy functioning of the electronic system, the switch is left in the Auto position. In this configuration the process is controlled by the normal functioning of the electronic system and its output. It may be important to know (remotely) if the process is being controlled manually or automatically, in which case the feedback contact on the Auto-Off-On module 19.21 can provide this.

Status indicating module (Type 19.31 and 19.32)

These single and dual channel indicating modules provides an immediate visual indication of the status of a controller input or output, emphasizing its importance or urgency according to the color of the LED. A change-over output contact which follows the input to the module is available if further control or where status feedback is required at another location - such as central control room.

These indicating modules can be used to signal, for example, that a heating unit is in its summer position and not turned on, or that it is heating under correctly functioning control etc. The module's legend plate clearly identifying the condition being monitored and signaled. EN 60073 defines the color RED for danger conditions; GREEN for secure normal operation; and BLUE for a prescribed activity, e.g. fire or other alarm condition. The LED indicator color being pre-selected using the switch on the back of the module.

Override Control Modules (Type 19.41 and 19.42) may be installed if, in the event of a electronic system malfunction, emergency working has to be restored by means of manual intervention. On notice of a malfunctioning system, perhaps through a feedback contact from a Status Indicating Module, the caretaker on-site can then go to control panel housing the appropriate Override module and respond to the malfunction by manipulation of the Auto-Off-Hand switch. The 19.41 module has a three-position switch marked A-O-H. A= Automatic operation, O=OFF and H=Hand (or Manual operation).

Moving away from the Auto position means that the module's output relay is no longer under the control of the defective electronic Control System. Turning the switch to "H" energizes the output relay, whilst selecting the "O" position ensures the relay is de-energized.

For example: a defective heating control system can be manually overridden to be On in the "H" position or Off in the "O" position. In this way heating can be maintained until the faulty controller can be replaced.

The module's green LED will indicate that the Heating is On, whilst the flashing Yellow LED is a reminder that the task is under manual control, and that on the replacement of the defective electronic control system the Auto-Off-Hand switch should be returned to the "A" position.

The 19.42 override module is similar in principle to the 19.41 module except that it is intended for use with two-stage operations as associated with star-delta motor starting, two-speed fan motors, or forward/reverse motor switching. In these applications it is usually necessary to incorporate a "dead" time of > 50ms between the two On states. Consequently, when manually switching with the 19.42, between the "Low" and "High" state and vice versa, a "dead" time of > 80ms is provided for, within the module.

Note of caution: Where the reversal of motor direction is achieved by dual motor windings and a switched capacitor, an interval of approximately 300 ms should be provided. This will need to be provided by the inclusion of a separate timer in the control circuitry. To protect motors with a high moment of inertia (such as large fans and flywheels); when switching from high speed to lower speed, the lower speed should only be switched on when the motor has come nearly to a complete halt.

Analogue Override control module

Analogue output module (0...10)V (Type 19.50)

This module can be installed where there is need to give a manually adjustable analog signal (0...10)V priority over an analog signal from a electronic control unit or PLC, or to override and replace a malfunctioning signal.

The Analogue override module provides, by the selection switch on the front panel, a (0...10)V output signal either generated automatically or by hand. With the selector switch in position "A" (Automatic) the (0...10)V signal at Yout-A2 is derived from the controller signal applied to terminals Yin-A2. In position "H" (Hand) the controller signal is ignored and the (0...10) V signal is derived directly from the potentiometer setting on the module front panel.

Operation in switch position H is indicated by a blinking yellow LED, and by the opening of contact 51-52 - which could be used to report the override condition to the central control room.

The level of the (0...10) V output signal is displayed by 3 green LEDs, set at >25%, >50% and >75%.

