

Description

Miniaturised single pole thermal circuit breaker with push-to-reset tease free, trip-free, snap action mechanism (R-type TO CBE to EN 60934). Available in versions for PCB or panel mounting, snap-in or threadneck, or as an integral type. Manual release facility optional for type 105.

Approved to CBE standard EN 60934 (IEC 60934). For higher current ratings see type 1140.

Typical applications

Motors, transformers, solenoids, printed circuit boards, hand-held machines and appliances, marine applications, caravans.

Ordering information

Type No.	
104	PCB mounting type (-PR), or integral type (-P30/P10)
105	snap-in panel mounting
106	threadneck panel mounting with hex and knurled nut *
106-M2	threadneck panel mounting 3/8-27UNS with collar, hex nut and knurled nut*
Terminal design	
P10	blade terminals A6.3-0.8 (QC .250)
P30	blade terminals A2.8-0.8 (QC .110)
PR	solder terminal pins for PCB mounting (type 104 only)
PR2	PCB mounting (vertical), type 104 only up to 6 A
PR3	PCB mounting (vertical), type 104 only
Shunt terminal (optional)	
A3	same as main terminals (up to I_N 6 A/3 A max. load)
Manual release facility (optional)	
H	only with type 105
Auxiliary contacts (optional)	
Si51	type 104 only
Current ratings	
0.05...10 A	
106 - P30 - .. - .. - .. - 5 A = ordering example	

The exact part number required can be built up from the table of choices shown above. Ordering references for optional features should be omitted if not required.

* mounting hardware bulk shipped

Standard current ratings and typical internal resistance values

Current rating (A)	Internal resistance (Ω)	Current rating (A)	Internal resistance (Ω)
0.05	285	1.8	0.28
0.08	134	2	0.25
0.1	81	2.5	0.18
0.2	22	3	0.11
0.3	8.7	3.5	0.076
0.4	5.5	4	0.067
0.5	3.3	4.5	0.051
0.6	2.45	5	≤ 0.05
0.7	1.6	6	≤ 0.05
0.8	1.45	7	≤ 0.05
1	0.9	8	≤ 0.05
1.2	0.6	10	≤ 0.05
1.5	0.4		



Technical data

For further details please see chapter: Technical Information

Voltage rating	AC 240 V; DC 48 V (UL: AC 250 V; DC 48 V)		
Current ratings	0.05...10 A		
Auxiliary circuit	0.5 A, AC 240 V, DC 28 V		
Typical life			
AC 240 V	0.05...8 A	2,000 operations at 1 x I_N , inductive	
	0.05...5 A	3,000 operations at 2 x I_N , inductive	
	6...8 A:	500 operations at 2 x I_N , inductive	
DC 48 V	0.05...8 A	2,000 operations at 1 x I_N , inductive	
	0.05...5 A	3,000 operations at 2 x I_N , inductive	
	6...8 A:	500 operations at 2 x I_N , inductive	
	10 A	200 operations at 1 x I_N , inductive	
	10 A	50 operations at 2 x I_N , inductive	
Ambient temperature	-20...+60 °C (-4...+140 °F) T 60		
Insulation co-ordination (IEC 60664 and 60664 A)	rated impulse withstand voltage	pollution degree	
	2.5 kV	2	
	reinforced insulation in operating area		
Dielectric strength (IEC 60664 and 60664A)	test voltage		
operating area	AC 3,000 V		
Insulation resistance	>100 MΩ (DC 500 V)		
Interrupting capacity I_{cn}	0.05...8 A	6 x I_N AC	
	> 8...10 A	5 x I_N AC	
	0.05...10 A	6 x I_N DC	
Interrupting capacity (UL 1077)	I_N	U_N	
	0.05...10 A	AC 250 V	2000 A
	0.05...10 A	DC 48 V	200 A
Degree of protection (IEC 60529/DIN 40050)	operating area IP40 terminal area IP00		
Vibration	10 g (57-500 Hz), ±0.76 mm (10-57 Hz), to IEC 60068-2-6, test Fc, 10 frequency cycles/axis		
Shock	25 g (11 ms) to IEC 60068-2-27, test Ea		
Corrosion	96 hours at 5 % salt mist, to IEC 60068-2-11, test Ka		
Humidity	240 hours at 95 % RH, to IEC 60068-2-3, test Ca		
Mass	approx. 10 g		

Approvals

Authority	Voltage ratings	Current ratings
VDE, SEV,	AC 240 V	0.05...8 A
Kema (EN 60934)	DC 48 V	0.05...10 A
CSA, UL	AC 250 V, DC 48 V	0.05...10 A

Circuit breakers with -Si51 not approved

Dimensions

104-P30

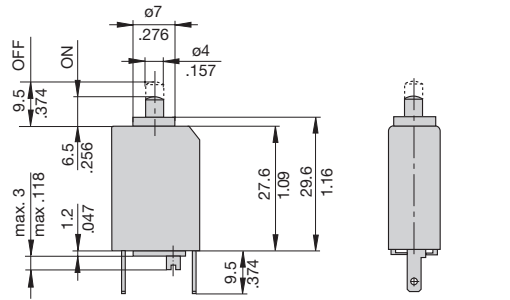

hole for mounting screw M2
 usable depth 4.5 mm (.177 in.)

blade terminals
 DIN 46244-A2.8-0.8
 (QC .110)

cut-out dimensions

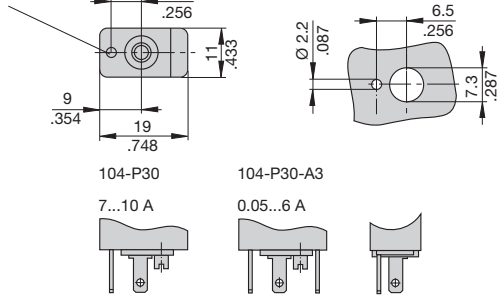

104-PR

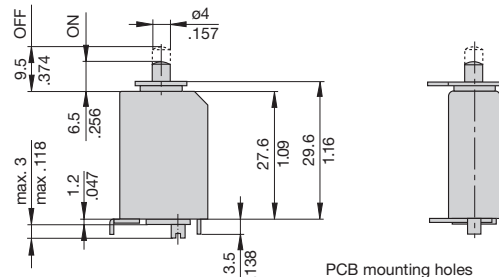

PCB mounting holes

104-PR
 104-PR-A3
 0.05...6 A

104-PR
 7...10 A

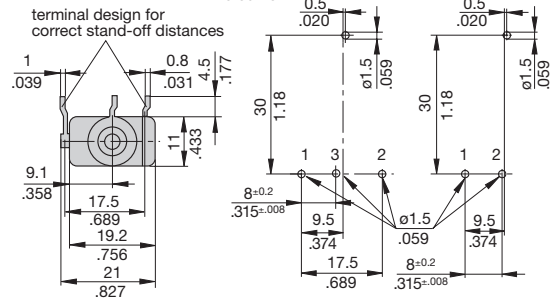

104-PR3

0.05...6 A

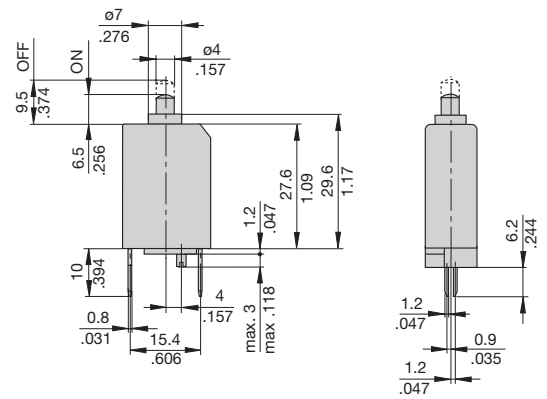

PCB mounting holes

0.05...6 A

hole for mounting screw M2x5

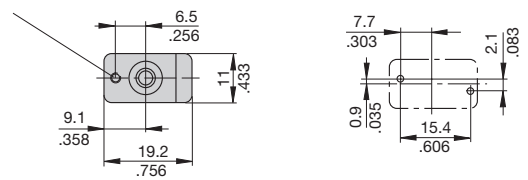

7...10 A

7...10 A

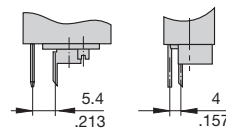

104-PR-(A3)-Si51

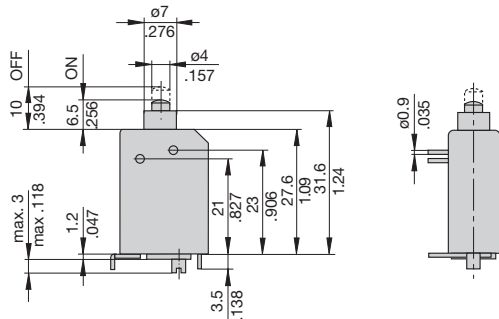

terminal design for correct stand-off distances

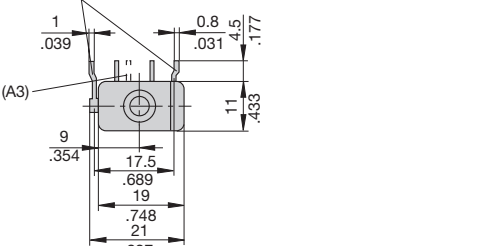

PCB mounting holes

104-PR-Si51
 104-PR-A3-Si51
 0.05...6 A

104-PR-Si51
 7...10 A

This is a metric design and millimeter dimensions take precedence (mm/inch)

Dimensions

104-PR2

0.05...6 A

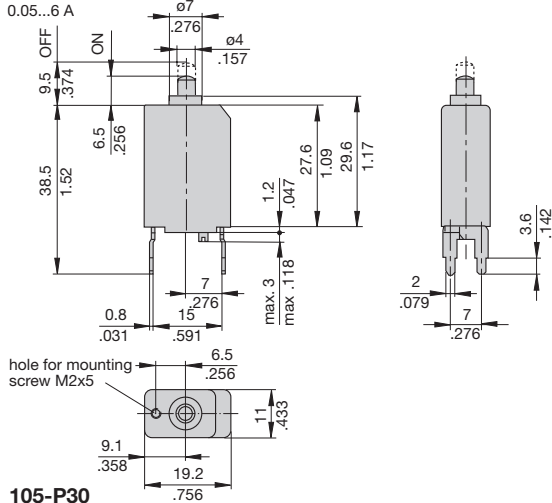

105-P30

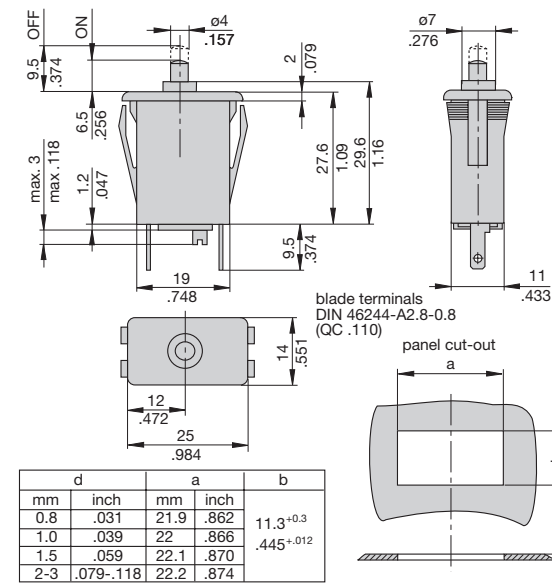

105-P..-H

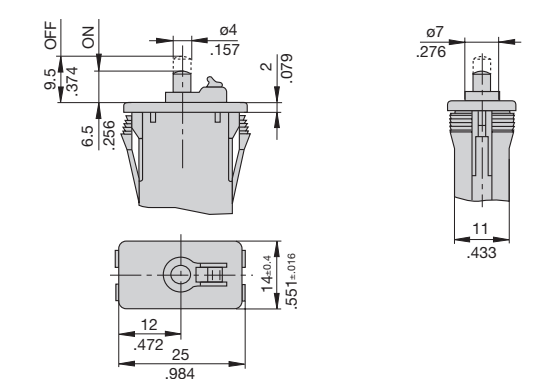

106-P30

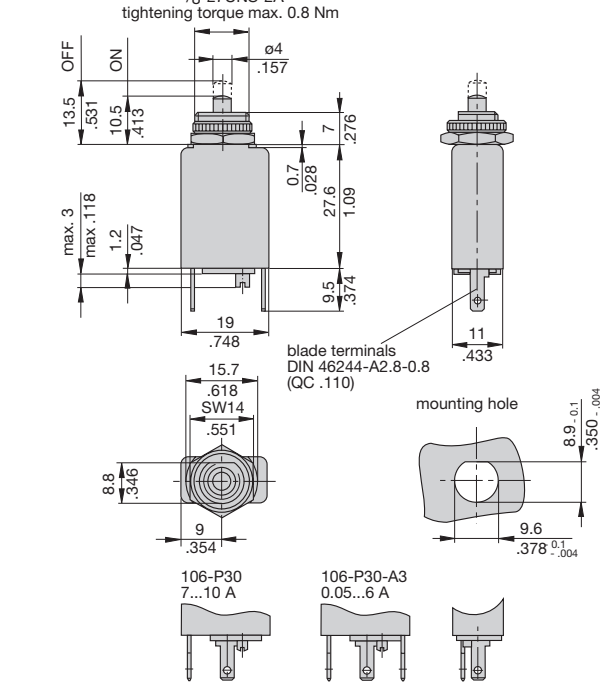

106-M2

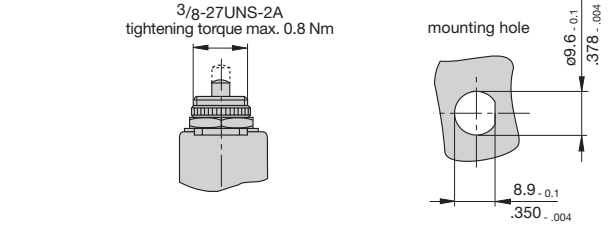

Terminal design

104/105/106-P10

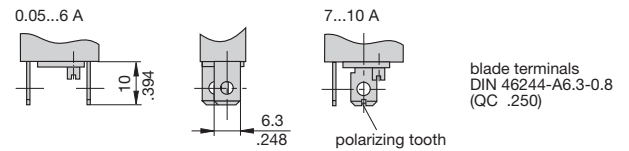

104/105/106-P10-A3

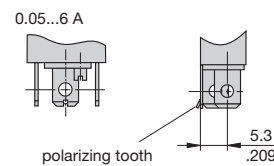

104/105/106-P30-A3

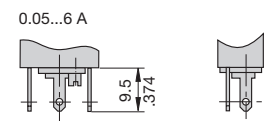

This is a metric design and millimeter dimensions take precedence (mm / inch)

Installation drawings

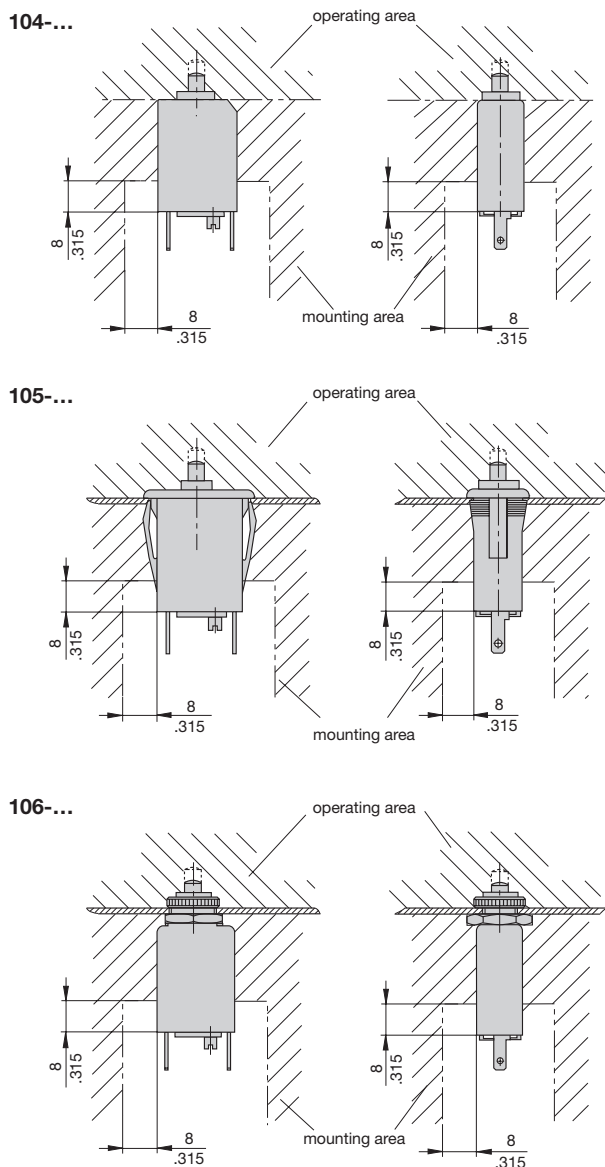

Internal connection diagrams

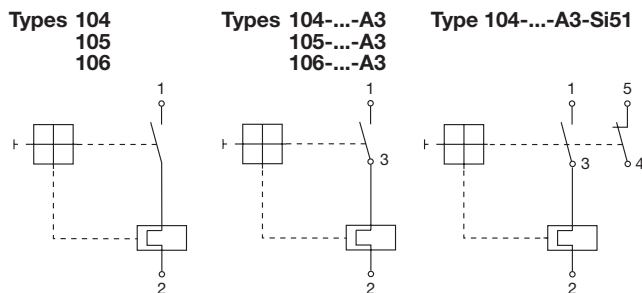

Typical time/current characteristics at +23°C/+73.4°F

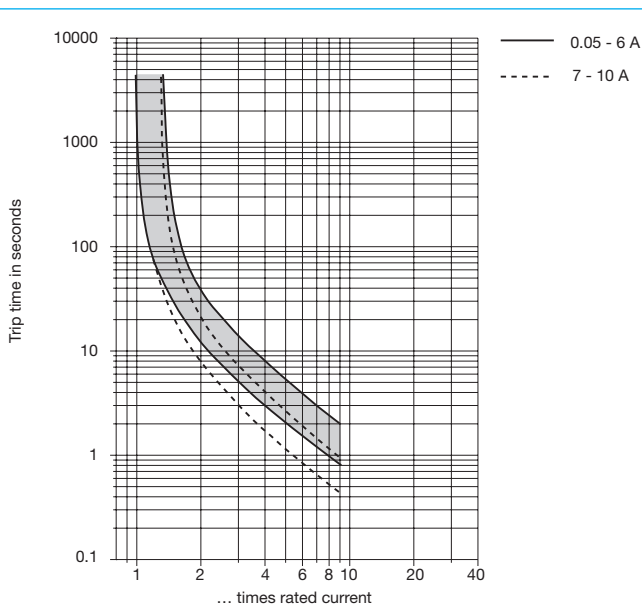

The time/current characteristic curve depends on the ambient temperature prevailing. In order to eliminate nuisance tripping, please multiply the circuit breaker current ratings by the derating factor shown below. See also section 9 – Technical information.

Ambient temperature °F	-4	+14	+32	+73.4	+104	+122	+140
°C	-20	-10	0	+23	+40	+50	+60
Derating factor	0.76	0.84	0.92	1	1.08	1.16	1.24

Accessories

Water splash cover (transparent)/knurled nut assembly
(type 106-... only)
X 201 285 01
Degree of protection IP 64

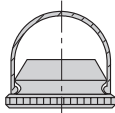

This is a metric design and millimeter dimensions take precedence $\left(\frac{\text{mm}}{\text{inch}}\right)$

All dimensions without tolerances are for reference only. In the interest of improved design, performance and cost effectiveness the right to make changes in these specifications without notice is reserved. Product markings may not be exactly as the ordering codes. Errors and omissions excepted.