

Description

One, two and three pole thermal-magnetic circuit breakers with tripping mechanism and toggle actuation (S-type TM CBE to EN 60934/IEC 934). Designed for panel or plug-in mounting. Available with auxiliary contacts (1 x N/O, 1 x N/C) for status signalling. Two and three pole models are internally linked to ensure that both/all poles trip in the event of an overload on one pole, even if the actuator is held in the ON position. A choice of characteristic curves further extends the range of applications possibilities for these CBEs. Special auxiliary contact versions for industrial atmosphere and low voltages (e. g. 5 V) available on request.

Approved to CBE standard EN 60934 (IEC 60934).

Suitable for use in distribution rails – see section Power Distribution Systems.

Typical applications

Process control equipment, robotics, machine tool control, communications systems, instrumentation, rail vehicles. Special versions, e.g. for aggressive environmental conditions and low voltages (e. g. 5 V) on request.

Standard current ratings and typical internal resistance values

Current rating (A)	Internal resistance (Ω)				
	F1	F2	M1	T1	M3
	fast acting for DC only	fast acting delay for AC+DC	standard for AC+DC	delayed low resistance only for AC	standard delay
0.1	162	162	92	81	-
0.2	39.3	39.3	26.1	24.2	-
0.3	17.5	17.5	11.6	10.4	-
0.4	9.2	9.2	6.6	6.0	-
0.5	6.8	6.8	4.1	3.9	-
0.6	4.2	4.2	3	2.7	-
0.8	2.8	2.8	1.65	1.53	-
1	1.6	1.6	1.10	0.98	0.5
1.5	0.78	0.78	0.47	0.42	0.22
2	0.42	0.42	0.28	0.24	0.136
2.5	0.26	0.26	0.183	0.17	0.083
3	0.18	0.18	0.124	0.12	0.057
4	0.12	0.12	0.077	0.073	0.041
5	0.092	0.092	0.063	0.055	0.032
6	0.054	0.054	0.045	0.039	0.021
8	0.025	0.025	≤ 0.02	≤ 0.02	≤ 0.02
10	0.022	0.02	≤ 0.02	≤ 0.02	≤ 0.02
12	≤ 0.02	≤ 0.02	≤ 0.02	≤ 0.02	≤ 0.02
16	≤ 0.02	≤ 0.02	≤ 0.02	≤ 0.02	≤ 0.02
20	-	-	≤ 0.02	≤ 0.02	-
25	-	-	≤ 0.02	≤ 0.02	-

Preferred types

Preferred types	Standard current ratings (A)						
	1	2	4	6	8	10	16
1-pole:							
2210-S211-P1F1-H111-	x	x	x	x	x		
2210-S211-P1M1-H111-	x	x	x	x	x	x	x
2210-S211-P1M1-Z111-	x	x	x	x	x	x	x
2-pole:							
2210-S221-P1M1-H111-	x	x	x	x	x	x	x
2210-S221-P1M1-H211-	x	x	x	x	x	x	x



2210-S2..

Technical data

For further details please see: http://www.e-t-a.de/ti_e

Voltage rating	AC 250 V*; 3 AC 433 V (50-60Hz); DC 65 V (*UL: AC 277/480 V; DC 65 V)	
Current rating range	0.1...25 A for curves M1, T1 0.1...16 A for curves F1, F2 1...16 A for curves M3	
Auxiliary circuit	1 A, AC 240 V/DC 65 V, resistive (min. 10 V / 10 mA)	
Typical life	10,000 operations at 1 x I _N , inductive	
Ambient temperature	-30...+60 °C (-22...+140 °F) T 60	
Insulation co-ordination (IEC 60664 and 60664A)	rated impulse withstand voltage 2.5 kV	pollution degree 2 reinforced insulation in operating area
Dielectric strength (IEC 60664 and 60664A)	test voltage	operating area
	AC 3,000 V	main/aux. circuit
	AC 1,500 V	aux. circuit 11-12/23-24
	AC 1,000 V	pole/pole
	AC 1,500 V	
Insulation resistance	> 100 MΩ (DC 500 V)	
Interrupting capacity I _{cn}	0.1...5 A 400 A 6...25 A 800 A	
curves F1, F2, M1, T1:	0.1...16 A 2,500A	(at DC 32 V)
curve M3:	1...2 A AC 200 A	DC 400 A
Interrupting capacity (UL 1077)		
I _N	0.1...16 A	20...25 A
AC 277 V 1-pole	5,000 A	2,000 A
AC 277/480 V 2-/3-pole	5,000 A	2,000 A
DC 65 V	2,000 A	2,000 A
Degree of protection (IEC 60529/DIN 40050)	operating area IP30 terminal area IP00	
Vibration	curves F1, F2: 3 g (57-500 Hz), ± 0.23 mm (10-57 Hz) curves M1, M3, T1: 5 g (57-500 Hz), ± 0.38 mm (10-57 Hz) to IEC 60068-2-6, test Fc 10 frequency cycles/axis	
Shock	curves F1, F2: 25 g (11 ms), directions 1, 2, 3, 4, 5 10 g (11 ms), direction 6 curves M1, M3, T1: 25 g (11 ms), directions 1, 2, 3, 4, 5 20 g (11 ms), direction 6 to IEC 60068-2-27, test Ea	
Corrosion	96 hours in 5 % salt mist to IEC 60068-2-11, test Ka	
Humidity	240 hours at 95 % RH to IEC 60068-2-78, test Cab	
Mass	approx. 50 g per pole	

Internal connection diagrams

with auxiliary contact function 1 (one each N/O and N/C)
 (...-H111-...) without intermediate position
 (...-Z111-...) with intermediate position

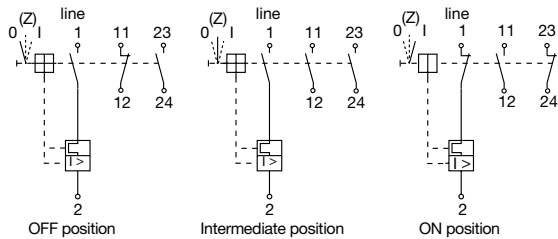

with auxiliary contact function 4 (1 N/O, leading)

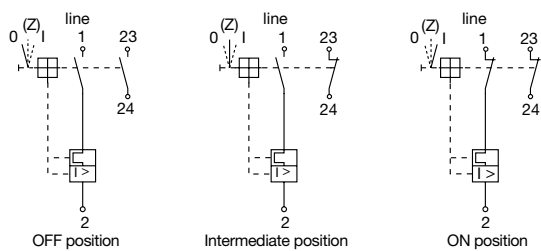

Toggle positions

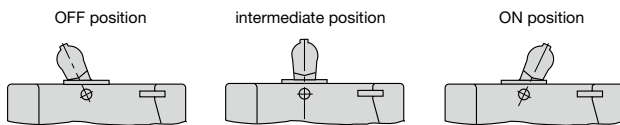

Shock directions

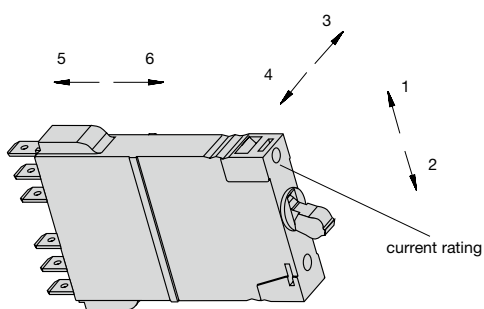

Typical time/current characteristics

-F1 0.1...16 A DC only

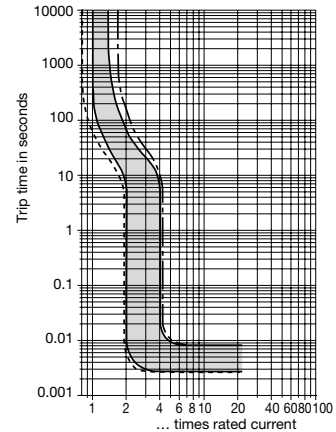

-F2 0.1...7.5 A AC/DC¹⁾

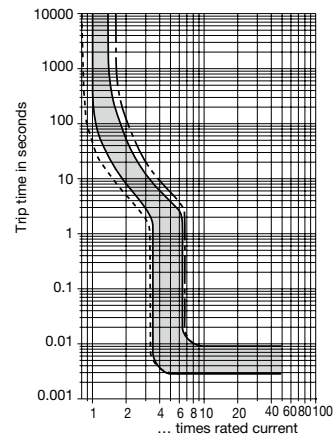

-F2 8...16 A AC/DC¹⁾

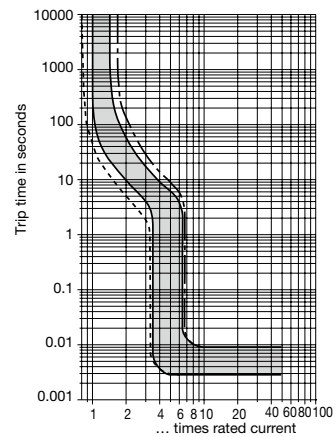

--- +60 °C +140 °F ——— +23 °C +73.4 °F - - - -30 °C -22 °F

¹⁾Magnetic tripping currents are increased by 30 % on DC supplies.

Multipole devices: all poles symmetrically loaded. With single pole overload, thermal tripping will be at max. $1.7 \times I_N$ with curves F1, F2 and M1 at max. $2.2 \times I_N$ with curve M3.

The time/current characteristic curve depends on the ambient temperature prevailing. In order to eliminate nuisance tripping, please multiply the circuit breaker current ratings by the derating factor shown below. See also section Technical information.

Ambient temp.	-22 °F -30 °C	-4 °F -20 °C	+14 °F -10 °C	+32 °F 0 °C	+73.4 °F +23 °C	+86 °F +30 °C	+104 °F +40 °C	+122 °F +50 °C	+140 °F +60 °C
Derating factor	0.76	0.79	0.83	0.88	1	1.04	1.11	1.19	1.29

Typical time/current characteristics

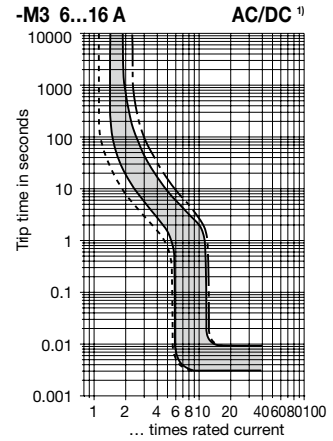
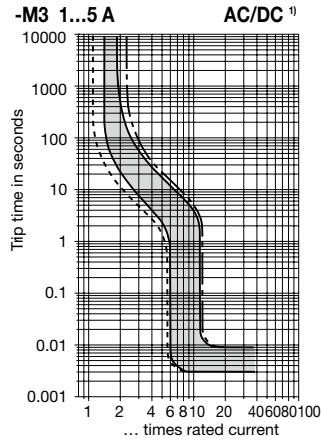
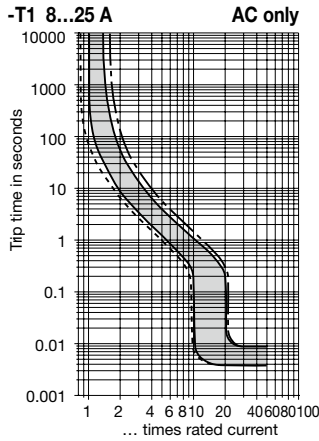
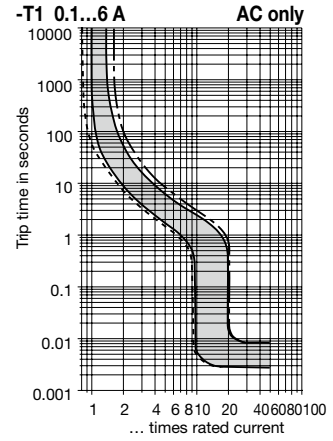
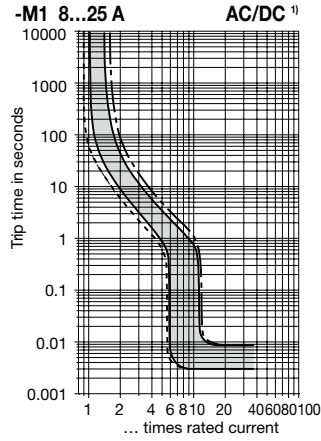
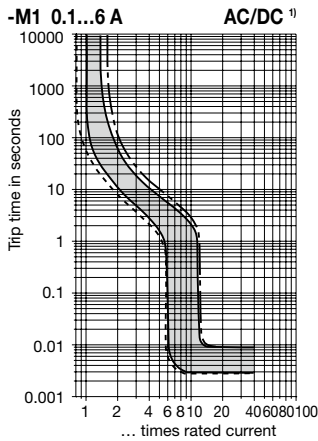

The time/current characteristic curve depends on the ambient temperature prevailing. In order to eliminate nuisance tripping, please multiply the circuit breaker current ratings by the derating factor shown below. See also section Technical information.

Ambient °F	-22	-4	+14	+32	+73.4	+86	+104	+122	+140
temp. °C	-30	-20	-10	0	+23	+30	+40	+50	+60
Derating factor	0.76	0.79	0.83	0.88	1	1.04	1.11	1.19	1.29

Multi pole devices: all poles symmetrically loaded. With single pole overload, thermal tripping will be at max. $1.7 \times I_N$ with curves F1, F2 and M1 at max. $2.2 \times I_N$ with curve M3.

¹⁾ Magnetic tripping currents are increased by 30% on DC supplies (curves F2, M1, M3).

Accessories

Module 17plus
For technical data see section Power Distribution Systems

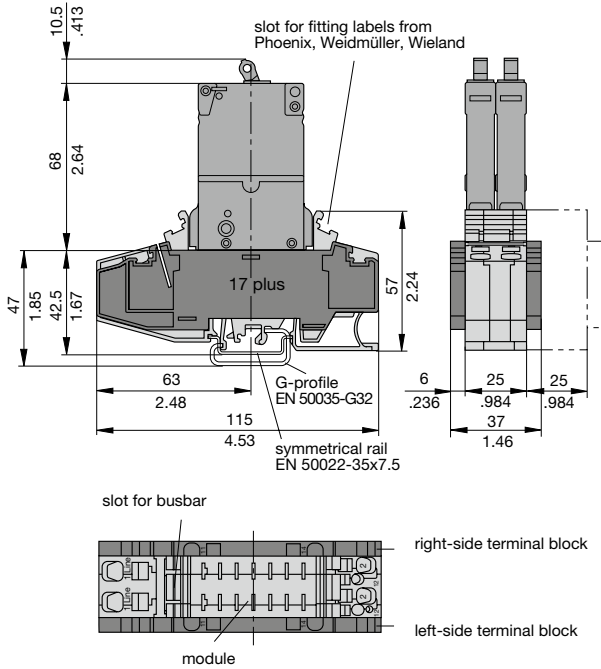

2-way mounting socket
23-P10-Si
(up to 16 A max. load)
(retaining clip Y 302 974 01 available on request)

6-way mounting socket
63-P10-Si

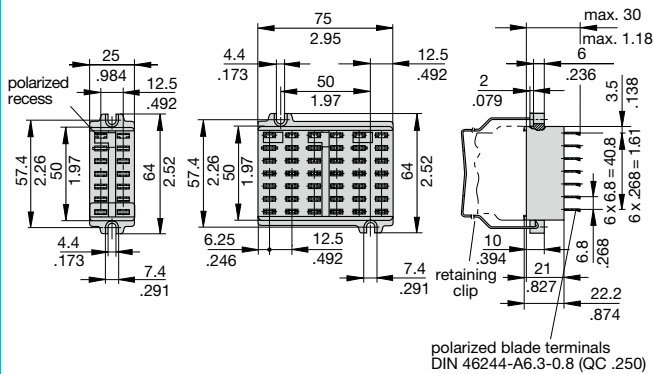

Bus bar 50 A, 6-way, for type 63-P10-Si socket
X 221 760 11

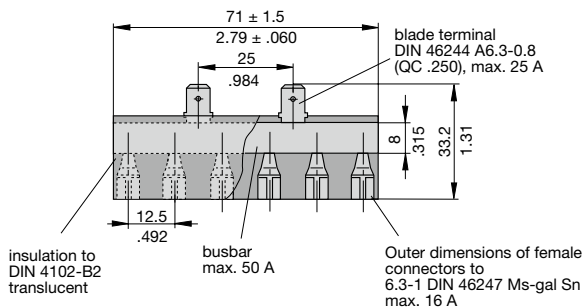

Single mounting sockets (with adapter)
(up to 16 A max. load)
17-P10-Si
17-P70-Si
(retaining clip Y 302 974 21 available on request)

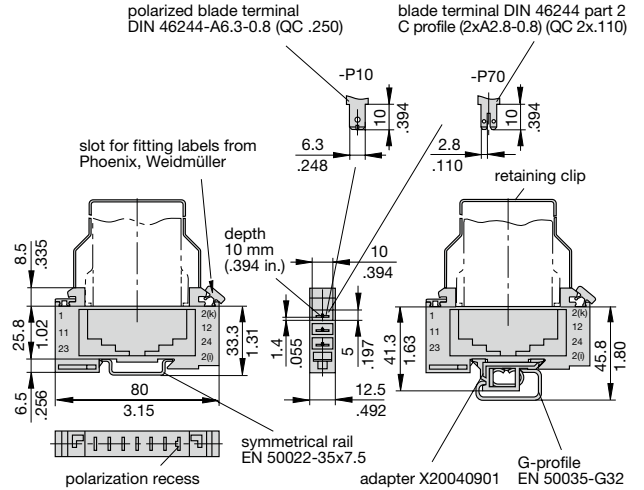

Bus bar 50 A (6-way) for type 17-P10-Si socket
X 221 760 01

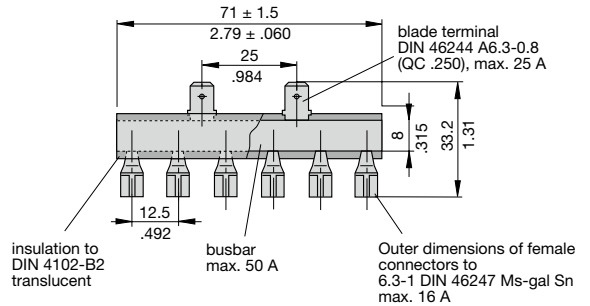

Bus bar (10-way) (supplied as a complete package) for type 17 socket
(for max. 100 A continuous load), more positions available on request
X 211 157 01 with terminal
X 211 157 02 without terminal

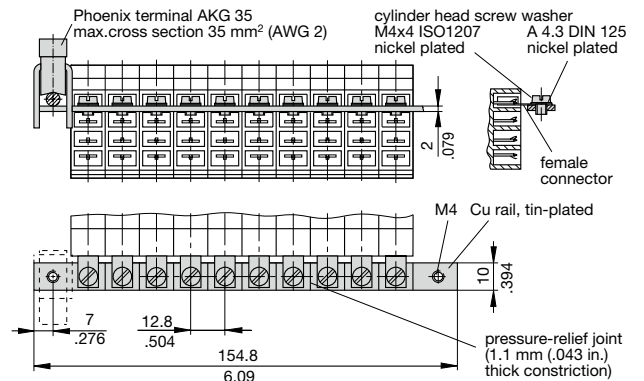

Insulating sleeving for bus bar (10-way)
Y 303 824 01

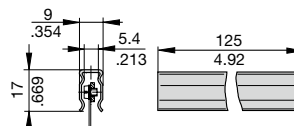

This is a metric design and millimeter dimensions take precedence (mm/inch)



Accessories

Connector bus links -P10

- X 210 588 01/ 1.5 mm², (AWG 16), brown (up to 13 A max. load)
- X 210 588 02/ 2.5 mm², (AWG 14), black (up to 20 A max. load)
- X 210 588 03/ 2.5 mm², (AWG 14), red (up to 20 A max. load)
- X 210 588 04/ 2.5 mm², (AWG 14), blue (up to 20 A max. load)

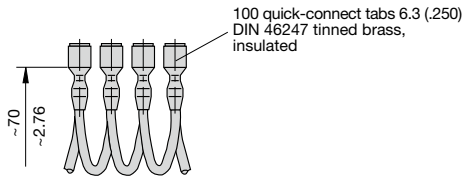

Toggle guard for 1-pole units, black
X 221 617 01

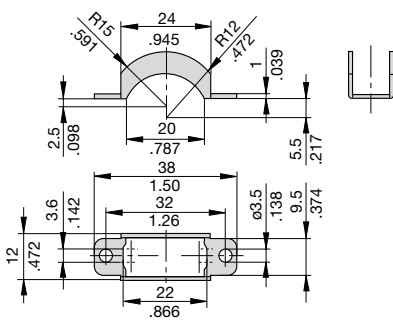

For front panel mounting.

Splash cover (transparent) with fixing plate and screws (IP54) for type 2210-S211-... (1-pole)
X 211 117 02

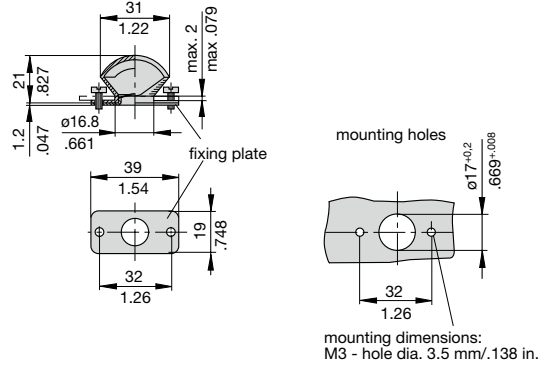

Splash cover (transparent) with fixing plate and screws (IP54) for type 2210-S221-... (2-pole) and type 2210-S231-... (3-pole)
X 211 118 01

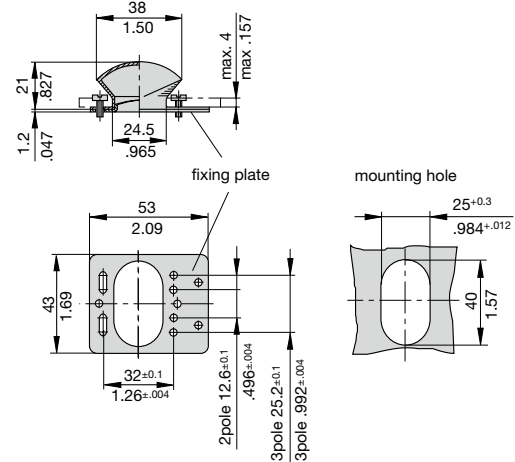

This is a metric design and millimeter dimensions take precedence (mm/inch)

All dimensions without tolerances are for reference only. In the interest of improved design, performance and cost effectiveness the right to make changes in these specifications without notice is reserved. Product markings may not be exactly as the ordering codes. Errors and omissions excepted.