

REAL TIME CLOCK MODULE (SPI & I<sup>2</sup>C-Bus)

Power Switching and Low current consumption



Product Number  
RX6110SA B : X1B000232000100

RX6110SA B

- Built in frequency adjusted 32.768 kHz crystal unit.
- Interface Type : SPI & I<sup>2</sup>C -Bus
- Operating voltage range : 1.6 V to 5.5 V
- The wide voltage for time keeping : 1.1 V to 5.5 V
- Low backup current : 130 nA / 3 V ( Typ. )
- Built-in user RAM : 128 bit ( 8 bit × 16, SRAM)
- Auto power switching functions : When VDD deteriorates than 1.6V, internal source is switched to VBAT.

• The various functions include full calendar, alarm, timer.  
Epson prepared Linux driver for development.  
([http://www5.epsondevice.com/en/information/support/linux\\_rtc/](http://www5.epsondevice.com/en/information/support/linux_rtc/))

The registered trademark Linux® is used pursuant to a sublicense from LMI(Linux Mark Institute)  
The I<sup>2</sup>C-Bus is a trademark of NXP Semiconductors



Block diagram

Overview

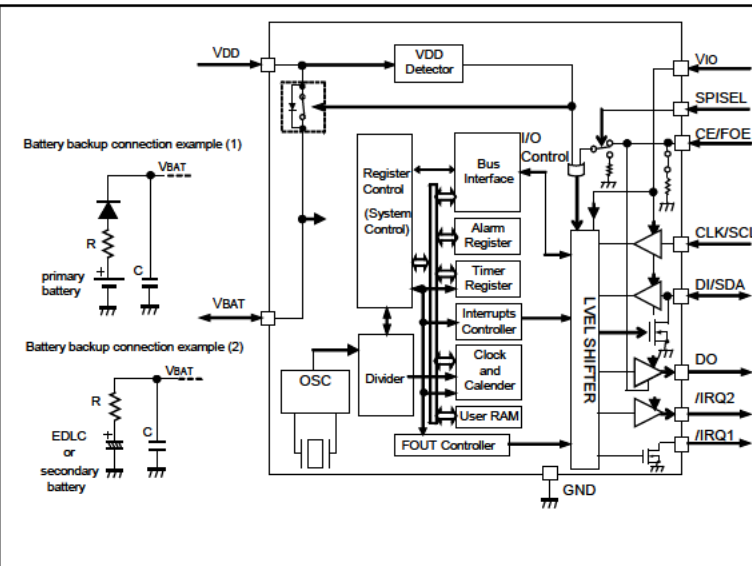

- Interface type.
  - SPI-Bus and I<sup>2</sup>C-Bus interface.
  - By a terminal, a switchover of the interface is possible.
- Built-in auto power switching function
  - To efficiently charge from VDD to backup battery (Secondary battery, Large capacitor) connected to VBAT is possible. Detects VDD voltage drop(VDET-) and automatically switches to the backup battery.
- Frequency output function
  - Output frequency is selectable from 32.768kHz, 1024Hz, 1Hz.
- Timer function
  - Timer function is selectable in 1/4096 second from 65535 hours.
  - Timer source clock are 1hour, 1min, 64Hz, 4096Hz.
  - It is recorded automatic to TF-bit at the time of event occurrence, and possible to output with / RQ1 or /IRQ2 pin.
- Alarm function
  - Alarm function can be set to day of week, day, hour, and minute.
  - It is recorded automatic to AF-bit at the alarm occurrence, and possible to output with / RQ1 pin output.
- User RAM
  - 128 bit ( 8 bit × 16, SRAM)

Pin Function

Terminal connection / External dimensions (Unit:mm)

Signal Name	Input/Output	Function
SPISEL	Input	The interface select pin. SPI is chosen at a "H" level (Vio voltage) / I <sup>2</sup> C is chosen at a "L" level (GND voltage).
CE/FOE	Input	SPI: Should be held high to allow access to the CPU. Incorporates a pull-down resistor. I <sup>2</sup> C: It is an input pin for controlling the DO/FOUT output. When the frequency output from a DO/FOUT pin does not need, CE/FOE pin must be connected to GND.
CLK/SCL	Input	This is a shift clock input pin for serial data transmission.
DI/SDA	Input / Output	SPI: This is the data input pin for serial data transfer. I <sup>2</sup> C: This is the data input/output pin for serial data transfer.
DO/FOUT	Output	SPI: This is the data output pin for serial data transfer. I <sup>2</sup> C: This is the C-MOS output pin with output control provided via the CE/FOE pin. (frequency selection: 32.768 kHz / 1024 Hz / 1Hz / Hi-z)
/ IRQ1	Output	This pin outputs interrupt signals ("L" level) for alarm, timer, time update, and FOUT. This is an N-ch open-drain output. This pin can output even a backup mode.
/ IRQ2	Output	This pin outputs interrupt signals ("L" level) for timer and FOUT. This is an C-MOS output. This pin becomes Hi-z in less than VDD=1.6V.
VDD	-	This is a power-supply pin. It can impress the voltage unlike Vio.
Vio	-	This pin is a power supply for input and the output and input / output pins. Connected to a positive power supply.
VBAT	-	Connect a secondary battery or capacitor for backup power supply. If a backup power supply is not present, this pin connect to VDD.
GND	-	Connected to a ground.

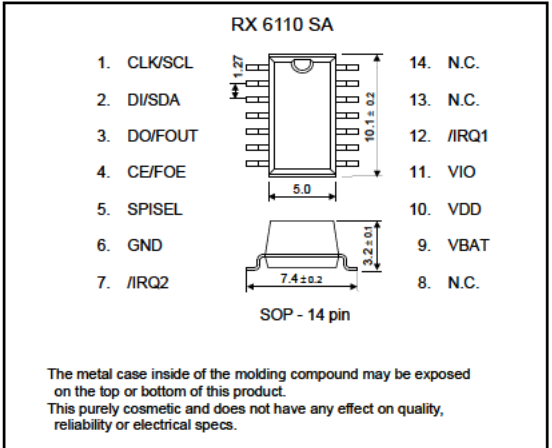

The metal case inside of the molding compound may be exposed on the top or bottom of this product.  
This purely cosmetic and does not have any effect on quality, reliability or electrical specs.

Specifications (characteristics)

\* Refer to application manual for details.

■ Recommended Operating Conditions

Item	Symbol	Conditions	Min.	Typ.	Max.	Unit
Power voltage	VDD	—	1.6	3.0	5.5	V
Clock voltage	VCLK	—	1.1	3.0	5.5	V
Operating temperature	TOPR	—	-40	+25	+85	°C

■ Frequency characteristics

Item	Symbol	Conditions	Rating	Unit
Frequency tolerance	Δf/f	Ta = +25 °C VDD = 3.0 V	B: 5 ± 23 *1	× 10 <sup>-6</sup>
Oscillation start-up time	tSTA	Ta = +25 °C VDD = 1.6 V	1 Max.	s

■ Current consumption characteristics Ta = -40 °C to +85 °C

Item	Symbol	Conditions	Min.	Typ.	Max.	Unit
Current Consumption	BK	VBAT = 3.0 V Input pins are "L", VDD = 0 V DO/FOUT=OFF, fCLK = 0 Hz, /IRQ1,2 = OFF, TSEL2="1" It include an OFF leak current of SW between the power supply (VBAT-VDD)	-	130	250	nA
	I32k	VDD = 3.0 V fCLK = 0 Hz, /IRQ1,2 = OFF, CE/FOE = VIO, DO/FOUT : 32.768 kHz ON, CL = 0 pF	-	1.5	2.1	μA

\*1) Equivalent to ±1 minute of monthly deviation (excluding offset.) / Standard product