



REAL TIME CLOCK MODULE (SPI-Bus)

Built-in 32.768 kHz-DTCXO, High Stability

Product Number
RX-4803SA : X1B000131xxxx00
RX-4803LC : X1B000122xxxx00
RX-4803LC UB : X1B000122000200

RX-4803SA / LC

- Built in frequency adjusted 32.768 kHz crystal unit and DTCXO.
 - 1/100s resolution Time register
 - Interface Type : 4-wire serial interface
 - Interface voltage range : 1.6 V to 5.5 V
 - Temp. compensated voltage range : 2.2 V to 5.5 V
 - Clock supply voltage range : 1.6 V to 5.5 V
 - Selectable clock output (32.768 kHz, 1024 Hz, 1 Hz)
 - The various functions include full calendar, alarm, timer, EVIN input. Epson prepared Linux driver for development.
http://www5.epsondevice.com/en/information/support/linux_rtc/
- The registered trademark Linux® is used pursuant to a sublicense from LMI(Linux Mark Institute)



RX-4803SA



RX-4803LC

Block diagram

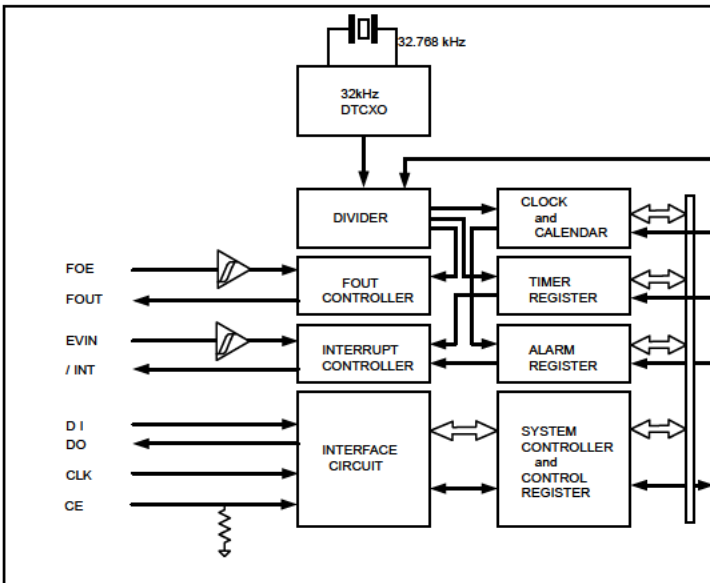

Overview

- **High Stability**
 - UA $\pm 3.4 \times 10^{-6}$ / -40 °C to +85 °C (Equivalent to ± 9 seconds of month deviation)
 - UB $\pm 5.0 \times 10^{-6}$ / -40 °C to +85 °C (Equivalent to ± 13 seconds of month deviation)
 - UC $\pm 5.0 \times 10^{-6}$ / -30 °C to +70 °C
 - AA $(+5 \pm 5.0) \times 10^{-6}$ / +25 °C
- **High Resolution:** 1/100s Time register with capture buffer
- **32.768 kHz frequency output function**
 - FOUT pin output (C-MOS output), CL=30 pF
 - Output selectable: 32.768 kHz, 1024 Hz, 1 Hz
- **The various interrupt**
 - Timer Function can be set between 1/ 4096 second and 4095 minutes.
 - Alarm Function can be set to day of week, day, hour, or minute.
 - EVIN input.
- **Time synchronize function with 1PPS signal input**
- **Register compatibility:** upper compatible with RX-4801.

*It is possible to use it by the terminal connection as 32.768 kHz-DTCXO.

Pin Function

Signal Name	I / O	Function
CE	input	The chip enable input pin.
CLK	input	The shift clock input pin for serial data transfer.
FOUT	Output	The pin outputs the reference clock signal. (CMOS output)
TEST	input	Use by the manufacture for testing. (Do not connect externally. RX-4803SA only.)
V _{DD}	-	Connected to a positive power supply
FOE	input	The input pin for the FOUT output control.
EVIN	input	External event input. Open is prohibited
/INT	Output	Interrupt output (N-ch. open drain).
GND	-	Connected to a ground
T2(V _{PP})	-	Use by the manufacture for testing. (Do not connect externally.)
DO	Output	The data output pin for serial data transfer.
DI	input	The data input pin for serial data transfer.

Terminal connection / External dimensions

(Unit mm)

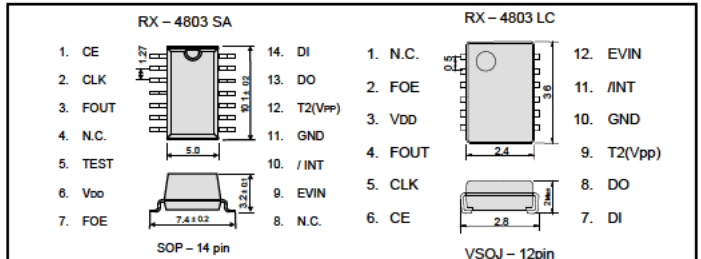

The metal case inside of the molding compound may be exposed on the top or bottom of this product. This purely cosmetic and does not have any effect on quality, reliability or electrical specs.

***Stop using the glue**
 Any glue must never use it after soldering LC-package to a circuit board. This product has glass on the back side of a package. When glue invasions between circuit board side and glass side, then glass cracks by thermal expansion of glue. In this case a crystal oscillation stops. Consider glue abolition or glue do not touch to LC-package

Specifications (characteristics)

* Refer to application manual for details.

Electrical Characteristics

Item	Symbol	Conditions	Min.	Typ.	Max.	Unit	
Interface voltage	V _{DD}	Interface voltage	1.6	3.0	5.5	V	
Temp. compensated Voltage	V _{TEM}	Temp. compensated voltage	2.2	3.0	5.5	V	
Clock supply voltage	V _{CLK}	-	1.6	3.0	5.5	V	
Operating temperature	T _{OPR}	No condensation	-40	+25	+85	°C	
Stability	$\Delta f/f$	UA	Ta = -40 °C to +85 °C	± 3.4 ^{*1}		$\times 10^{-6}$	
		UB	Ta = -40 °C to +85 °C	± 5.0 ^{*2}			
		UC	Ta = -30 °C to +70 °C				
		AA	Ta = +25 °C	5 ± 5.0 ^{*3}			
Current consumption (1)	I _{DD1}	Backup Mode FOE = GND, /INT = V _{DD} FOUT output : OFF	V _{DD} = 5V	-	0.75	3.4	μ A
Current consumption (2)	I _{DD2}		V _{DD} = 3V	-	0.75	2.1	μ A

^{*1}) Equivalent to ± 9 seconds of month deviation. ^{*2}) Equivalent to ± 13 seconds of month deviation.
^{*3}) Equivalent to ± 13 seconds of month deviation. (excluding offset)

32.768 kHz-DTCXO Frequency temperature characteristics (Example)

