

FX2000A ... FX2000G Fast Efficient Rectifier Diodes Schnelle Gleichrichterdiodes für hohen Wirkungsgrad	I_{FAV} = 20 A V_{F1} < 0.82 V T_{jmax} = 150°C	V_{RRM} = 50...400 V I_{FSM} = 650/715 A t_{tr} < 200 ns
--	---	--

Version 2019-01-14

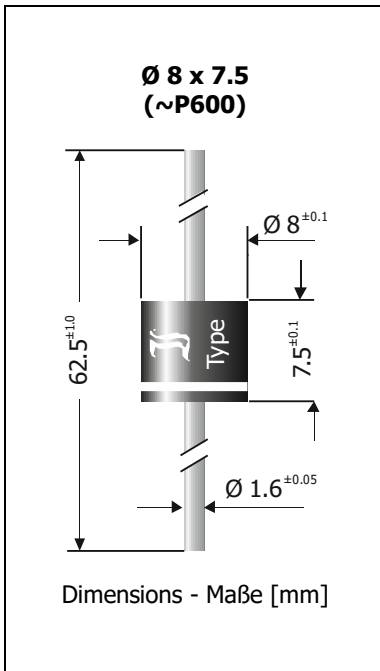

Typical Applications

Rectification of medium frequencies
 Free-wheeling diodes, Polarity Protection, Solar Bypass diodes
 Commercial grade ¹⁾

Features

Low forward voltage drop
 Low thermal resistance
 High forward surge capability
 Package smaller than industry standard
 Compliant to RoHS, REACH, Conflict Minerals ¹⁾

Mechanical Data ¹⁾

Taped in ammo pack	500
Weight approx.	2.0 g
Case material	UL 94V-0
Solder & assembly conditions	260°C/10s MSL N/A



Typische Anwendungen

Gleichrichtung mittlerer Frequenzen
 Freilaufdiodes, Verpolschutz
 Solar-Bypassdiodes
 Standardausführung ¹⁾

Besonderheiten

Niedrige Fluss-Spannung
 Niedriger Wärmewiderstand
 Hohe Stoßstromfestigkeit
 Gehäuse kleiner als Industriestandard
 Konform zu RoHS, REACH, Konfliktmineralien ¹⁾

Mechanische Daten ¹⁾

Gegurtet in Ammo-Pack	Gewicht ca.
	Gehäusematerial
	Löt- und Einbaubedingungen

Maximum ratings ¹⁾

Grenzwerte ²⁾

Type Typ	Repetitive peak reverse voltage Periodische Spitzensperrensorgung V _{RRM} [V]	Surge peak reverse voltage Stoßspitzensperrensorgung V _{RSM} [V]
FX2000A	50	50
FX2000B	100	100
FX2000D	200	200
FX2000F	300	300
FX2000G	400	400

Average forward current – Dauergrenzstrom	T _A = 50°C	I _{FAV}	20 A ²⁾
Repetitive peak forward current Periodischer Spitzenstrom	f > 15 Hz T _A = 50°C	I _{FRM}	130 A ³⁾
Peak forward surge current Stoßstrom in Fluss-Richtung	Half sine-wave Sinus-Halbwellen 50 Hz (10 ms) 60 Hz (8.3 ms)	I _{FSM}	650 A 715 A
Rating for fusing – Grenzlastintegral	t < 10 ms	i ² t	2112 A ² s
Junction temperature – Sperrschichttemperatur in DC forward mode – bei Gleichstrom-Durchlassbetrieb		T _j	-50...+150°C +200°C ^{3,4)}
Storage temperature – Lagerungstemperatur		T _s	-50...+175°C

1 Please note the [detailed information on our website](#) or at the beginning of the data book
 Bitte beachten Sie die [detaillierten Hinweise auf unserer Internetseite](#) bzw. am Anfang des Datenbuches

2 T_A = 25°C unless otherwise specified – T_A = 25°C wenn nicht anders angegeben

3 Valid, if leads are kept at T_A at 10mm distance from case – Gilt, wenn die Anschlüsse in 10mm vom Geh. auf T_A gehalten werden

3 For more details, ask for the Diotec Application Note "Reliability of Bypass Diodes"
 Weitere Infos in der Diotec Applikationsschrift „Reliability of Bypass Diodes“

4 Meets the Requirements of IEC 61215 bypass diode thermal test
 Erfüllt die Anforderungen des IEC 61215 Bypass-Diodentests

Characteristics
Kennwerte

Forward Voltage Durchlass-Spannung	$T_j = 25^\circ\text{C}$	$I_F = 5\text{ A}$ $I_F = 20\text{ A}$	V_F	$< 0.82\text{ V}$ $< 0.94\text{ V}$	
Leakage current Sperrstrom	$T_j = 25^\circ\text{C}$ $T_j = 100^\circ\text{C}$	$V_R = V_{RRM}$	I_R	$< 5\ \mu\text{A}$ $< 200\ \mu\text{A}$	
Reverse recovery time Sperrverzug	$I_F = 0.5\text{ A}$ through/über $I_R = 1\text{ A}$ to/auf $I_R = 0.25\text{ A}$		t_{rr}	$< 200\text{ ns}$	
Typical junction capacitance Typische Sperrschichtkapazität	$V_R = 4\text{ V}$		C_j	430 pF	
Typical thermal resistance junction to ambient Typischer Wärmewiderstand Sperrschicht – Umgebung				R_{thA}	$8\text{ K/W}^{1)}$
Typical Thermal resistance junction to leads Typischer Wärmewiderstand Sperrschicht – Anschlussdraht				R_{thL}	$1.5\text{ K/W}^{2)}$

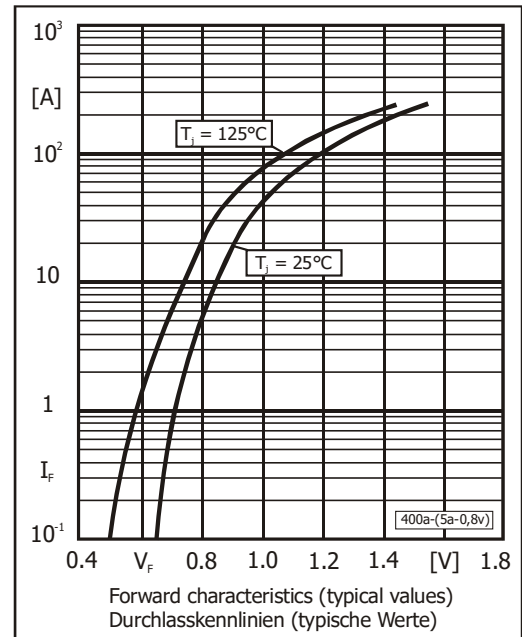
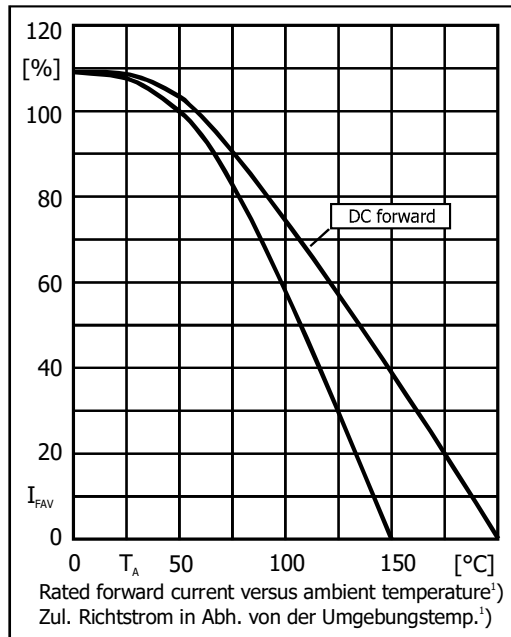

Disclaimer: See data book page 2 or [website](#)
Haftungsausschluss: Siehe Datenbuch Seite 2 oder [Internet](#)

- Valid, if leads are kept at ambient temperature at a distance of 10 mm from case
 Gültig, wenn die Anschlussdrähte in 10 mm Abstand vom Gehäuse auf Umgebungstemperatur gehalten werden
- Measured in 3 mm distance from case – use for bypass diodes test
 Gemessen in 3 mm Abstand vom Gehäuse – für Bypass-Diodentest