

FE6A ... FE6G Superfast Recovery Rectifier Diodes Gleichrichter mit superschnellem Sperrverzug	I_{FAV} = 6 A V_{F1} < 0.98 V T_{jmax} = 175°C	V_{RRM} = 50...400 V I_{FSM} = 200/220 A t_{tr} < 50 ns
---	--	---

Version 2017-07-25

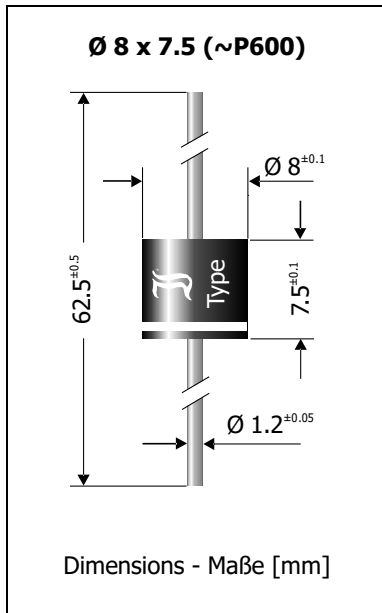

Typical Applications

Rectification of higher frequencies
 High speed switching
 Commercial grade ¹⁾

Features

V_{RRM} up to 400 V
 High forward surge current
 Package smaller than industry standard
 Compliant to RoHS, REACH, Conflict Minerals ¹⁾

Mechanical Data ¹⁾

Taped in ammo pack
 Weight approx.
 Case material
 Solder & assembly conditions



500
 1.3 g
 UL 94V-0
 260°C/10s
 MSL N/A

Typische Anwendungen

Gleichrichtung hoher Frequenzen
 Schnelles Schalten
 Standardausführung ¹⁾

Besonderheiten

V_{RRM} bis zu 400 V
 Hohe Stoßstromfestigkeit
 Gehäuse kleiner als Industriestandard
 Konform zu RoHS, REACH, Konfliktmineralien ¹⁾

Mechanische Daten ¹⁾

Gegurtet in Ammo-Pack
 Gewicht ca.
 Gehäusematerial
 Löt- und Einbaubedingungen

Maximum ratings ²⁾

Grenzwerte ²⁾

Type Typ	Repetitive peak reverse voltage Periodische Spitzenspannung V _{RRM} [V]	Surge peak reverse voltage Stoßspitzenspannung V _{RSM} [V]
FE6A	50	50
FE6B	100	100
FE6D	200	200
FE6F	300	300
FE6G	400	400

Max. average forward rectified current, R-load Dauergrenzstrom in Einwegschtung mit R-Last		I _{FAV}	6 A ³⁾
Repetitive peak forward current Periodischer Spitzenstrom	f > 15 Hz	I _{FRM}	50 A ³⁾
Peak forward surge current Stoßstrom in Fluss-Richtung	Half sine-wave Sinus-Halbwellle	50 Hz (10 ms) 60 Hz (8.3 ms)	I _{FSM} 200 A 220 A
Rating for fusing Grenzlastintegral	t < 10 ms	i ² t	200 A ² s
Junction temperature – Sperrschichttemperatur Storage temperature – Lagerungstemperatur		T _j T _s	-50...+175°C -50...+175°C

1 Please note the [detailed information on our website](#) or at the beginning of the data book
 Bitte beachten Sie die [detaillierten Hinweise auf unserer Internetseite](#) bzw. am Anfang des Datenbuches
 2 T_A = 25°C unless otherwise specified – T_A = 25°C wenn nicht anders angegeben
 3 Valid, if leads are kept at ambient temperature at a distance of 10 mm from case
 Gültig, wenn die Anschlussdrähte in 10 mm Abstand vom Gehäuse auf Umgebungstemperatur gehalten werden

Characteristics
Kennwerte

Type Typ	Reverse recovery time Sperrverzugszeit	Forward voltage Durchlass-Spannung		
$T_j = 25^\circ\text{C}$	$t_{rr} [\text{ns}]^1)$	$V_F [\text{V}]$	at / bei	$I_F = [\text{A}]$
FE6A ... FE6D	< 50	< 0.98		5
FE6F	< 50	< 1.00		5
FE6G	< 50	< 1.30		5

Leakage current – Sperrstrom	$T_j = 25^\circ\text{C}$	$V_R = V_{RRM}$	I_R	< 5 μA
Typical junction capacitance Typische Sperrschichtkapazität		$V_R = 4 \text{ V}$	C_j	135 pF
Thermal resistance junction to ambient Wärmewiderstand Sperrschicht – Umgebung			R_{thA}	< 20 K/W ²⁾
Thermal resistance junction to lead Wärmewiderstand Sperrschicht – Anschlussdraht			R_{thL}	< 6 K/W

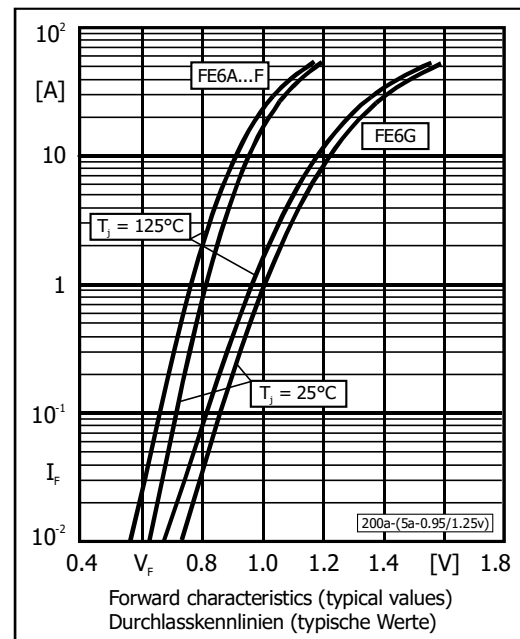
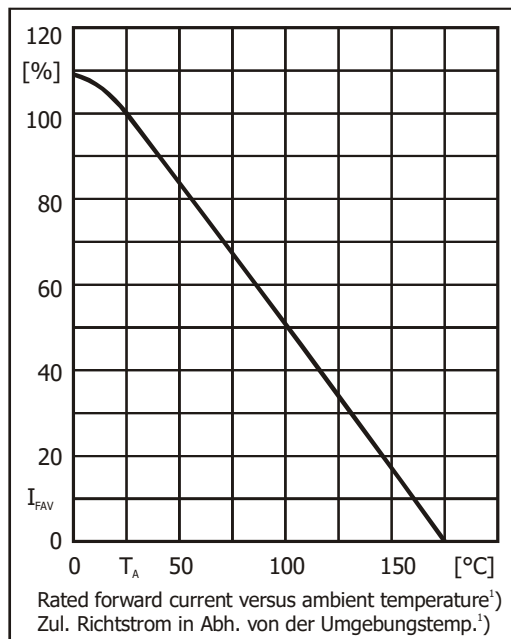

Disclaimer: See data book page 2 or [website](#)
Haftungsausschluss: Siehe Datenbuch Seite 2 oder [Internet](#)

- $I_F = 0.5 \text{ A}$ through/über $I_R = 1 \text{ A}$ to/auf $I_R = 0.25 \text{ A}$
- Valid, if leads are kept at ambient temperature at a distance of 10 mm from case
Gültig, wenn die Anschlussdrähte in 10 mm Abstand vom Gehäuse auf Umgebungstemperatur gehalten werden