

F11K120

Protectifiers® – LowV_F-Rectifier with Overvoltage Protection
Protectifiers® – LowV_F-Gleichrichter mit Überspannungs-Schutz

Version 2013-12-06

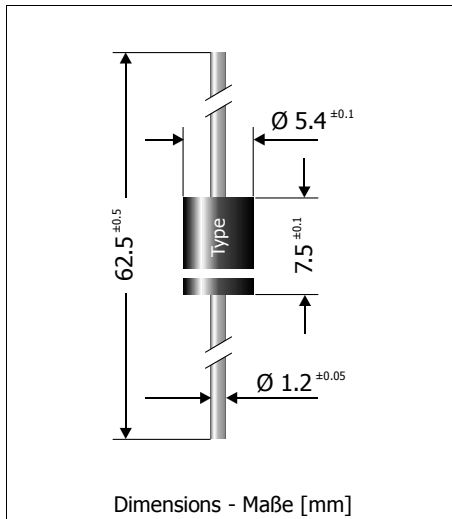

Nominal current 11 A
 Nennstrom

Stand off voltage 120 V
 Sperrspannung

Plastic case Ø 5.4 x 7.5 [mm]
 Kunststoffgehäuse (~ DO-201)

Weight approx. – Gewicht ca. 1.0 g

Plastic material has UL classification 94V-0
 Gehäusematerial UL94V-0 klassifiziert

Standard packaging taped in ammo pack
 Standard Lieferform gegurtet in Ammo-Pack



Low forward losses, high reverse pulse power capability
Niedrige Durchlass-Verluste, hohe Sperr-Belastbarkeit

Maximum ratings and Characteristics (T_J = 25°C)

Grenz- und Kennwerte (T_J = 25°C)

Type Typ	Stand-off voltage Sperrspannung V _{WM} [V]	Max. rev. current Max. Sperrstrom at/bei V _{WM} I _D [µA]	Breakdown voltage Abbruch-Spannung V _{BR min} [V]	Forward voltage Durchlass-Spannung V _F [V]
			@ I _T [mA]	I _F = 5A I _F = 11A
F11K120	120	5	130	5 < 0.97 < 1.10

Max. average forward rectified current, R-load Dauerstrom in Einwegschaltung mit R-Last	T _L = 50°C	I _{FAV}	11 A ¹⁾
Total steady state power dissipation Gesamtverlustleistung im Dauerbetrieb	T _A = 50°C	P _{tot}	5 W
Repetitive peak forward current – Periodischer Spitzenstrom	f > 15 Hz	I _{FRM}	50 A ¹⁾
Peak forward surge current, 50/60 Hz half sine-wave Stoßstrom für eine 50/60 Hz Sinus-Halbwelle	T _A = 25°C	I _{FSM}	250/280 A
Peak pulse power dissipation Impuls-Verlustleistung	10/1000µs pulse ²⁾ T _A = 25°C	P _{PPM}	700 W
Max. reverse peak pulse current Max. Impuls-Strom in Sperr-Richtung	8/20µs pulse ³⁾ T _A = 25°C	I _{PPM}	100 A
Rating for fusing, t < 10 ms – Grenzlastintegral, t < 10 ms	T _A = 25°C	i ² t	200 A ² s
Junction temperature – Sperrschichttemperatur in DC forward mode – bei Gleichstrom-Durchlassbetrieb		T _J	-50...+175°C +200°C
Storage temperature – Lagerungstemperatur		T _S	-50...+175°C

- Valid, if leads are kept at T_L at a distance of 3 mm from case
Gültig, wenn die Anschlussdrähte in 3 mm Abstand vom Gehäuse auf T_L gehalten werden
- See curve I_{pp} = f (t) 10/1000µs – Siehe Kurve I_{pp} = f (t) 10/1000µs
- See curve I_{pp} = f (t) 8/20µs – Siehe Kurve I_{pp} = f (t) 8/20µs

Characteristics
Kennwerte

Hot leakage current – Heiß-Sperrstrom	$T_j = 100^\circ\text{C}$ $V_R = V_{WM}$	I_R	< 100 μA
ESD rating according to JESD22-A114 / contact discharge ESD-Festigkeit gemäß JESD22-A114 / Kontaktentladung	$C = 100\text{pF}$ $R = 1.5\text{k}\Omega$		20 kV
Reverse recovery time Sperrverzug	$I_F = 0.5\text{ A}$ through/über $I_R = 1\text{ A}$ to $I_R = 0.25\text{ A}$	t_{rr}	< 350 ns
Thermal resistance junction to ambient air – Wärmewiderst. Sperrschicht – umg. Luft		R_{thA}	< 25 $\text{K/W}^1)$
Thermal resistance junction to leads – Wärmewiderst. Sperrschicht – Anschlussdraht		R_{thL}	< 10 K/W

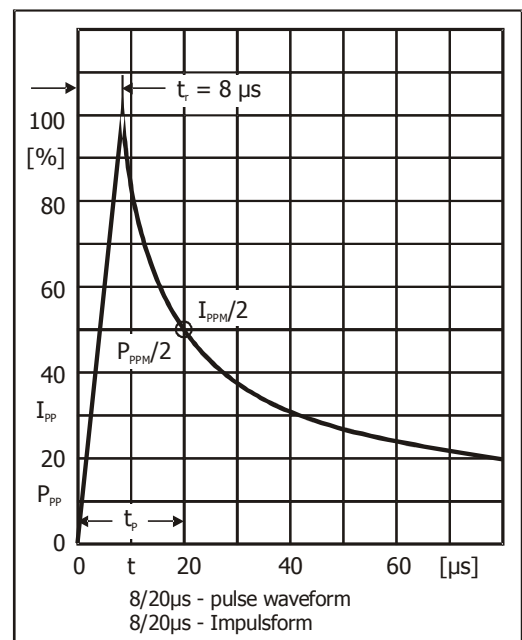
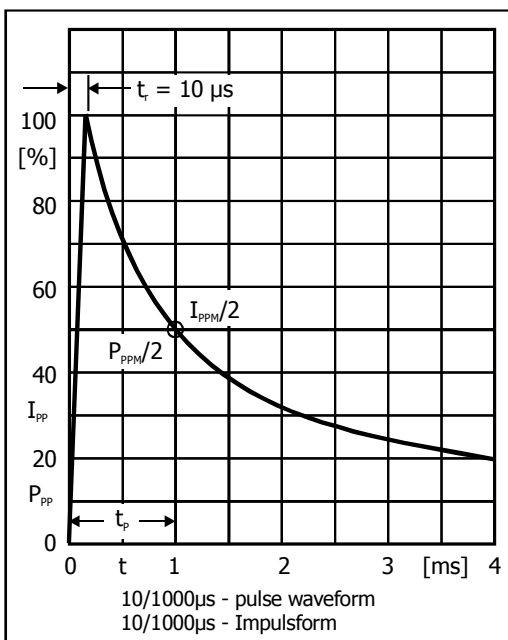
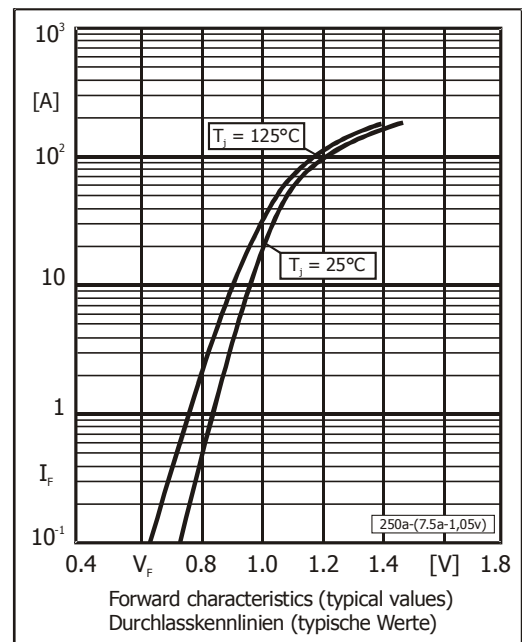
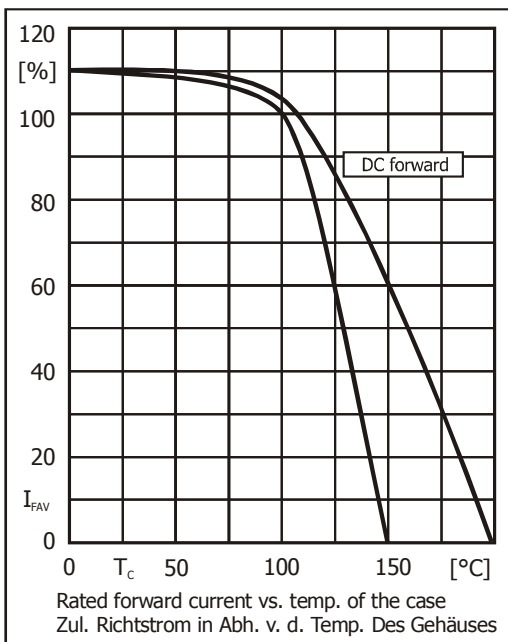

1 Valid, if leads are kept at ambient temperature at a distance of 10 mm from case
Gültig, wenn die Anschlussdrähte in 10 mm Abstand von Gehäuse auf Umgebungstemperatur gehalten werden