



PI74STX1G125

SOTiny™ Gate STX Buffer with 3-State Output

Features

- High-speed: $t_{PD} = 3.1\text{ns}$ typical into 50pF @ $5\text{V } V_{CC}$
- Broad operating range: $V_{CC} = 1.65\text{V} - 5.5\text{V}$
- Power down high-impedance inputs/outputs
- High output drive: $\pm 24\text{mA}$ at $3\text{V } V_{CC}$
- Package: 5-pin space saving SOT23 and SC70

Description

The PI74STX1G125 is a buffer with 3-state output that operates over the 1.65V to $5.5\text{V } V_{CC}$ operating range.

Pericom's PI74STX series of products are produced using the Company's advanced submicron technology.

Pinout

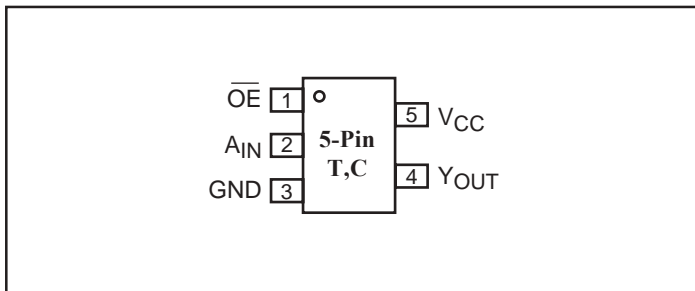

Block Diagram

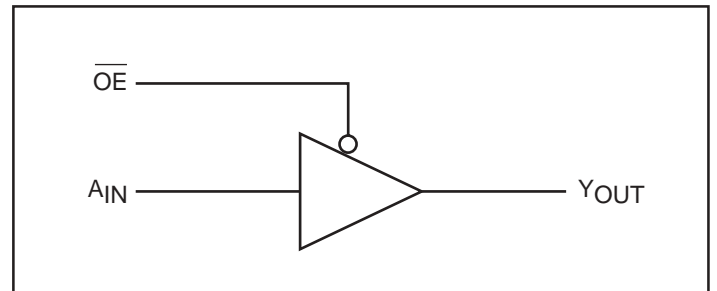

Pin Description

Pin Names	Description
A_{IN}	Input
\overline{OE}	Input
Y_{OUT}	Output

Function Table

Inputs		Output
\overline{OE}	A_{IN}	Y_{OUT}
L	L	L
L	H	H
H	X	Z

Note:

H = HIGH Logic Level
L = LOW Logic Level
Z = HIGH Impedance

Recommended Operating Conditions⁽¹⁾

Parameter	Condition	Min.	Max.	Units
Supply Voltage (V_{CC})		1.65	5.5	V
Input Voltage (V_{IN})		0	5.5	
Output Voltage (V_{OUT})		0	V_{CC}	
Operating Temperature		-40	85	°C
Input Rise and Fall Time (t_r, t_f)	$V_{CC} = 1.8\text{V}, 2.5\text{V} \pm 0.2\text{V}$	0	20	ns/V
	$V_{CC} = 3.3\text{V}, \pm 0.3\text{V}$	0	10	
	$V_{CC} = 5.0\text{V}, \pm 0.5\text{V}$	0	5	

Note:

1. Unused inputs must be held HIGH or LOW. They may not float.

Absolute Maximum Ratings

Supply Voltage (V _{CC})	-0.5V to +6V	DC V _{CC} /GND Current (I _{CC} /I _{GND})	±50mA
DC Input Voltage (V _{IN})	-0.5V to +6V	Storage Temperature (T _{STG})	-65°C to +150°C
DC Output Voltage (V _{OUT})	-0.5V to +6V	Junction Lead Temperature (IOS)	200°C
DC Input Diode Current (I _{IK})	-50mA to 20mA	Power Dissipation SOT23	200mW
DC Output Diode Current (I _{OK})	-50mA to 20mA	SC70	150mW
DC Output Current (I _{OUT})	±50mA		

Note:

Absolute maximum ratings are DC values beyond which the device may be damaged or have its useful life impaired. The datasheet specifications should be met, without exception, to ensure that the system design is reliable over its power supply, temperature, and output/input loading variables. Pericom does not recommend operation outside datasheet specifications.

DC Electrical Characteristics (Over supply voltage and operating temperature ranges, unless otherwise specified)

Symbol	Parameter	V _{CC} (V)	Conditions		T _A = +25°C			T _A = -40 to +85°C		Units
					Min.	Typ.	Max.	Min.	Max.	
V _{IH}	HIGH Level Input Voltage	1.65-1.95 2.3-5.5			0.75V _{CC} 0.70V _{CC}			0.75V _{CC} 0.70V _{CC}		
V _{IL}	LOW Level Input Voltage	1.65-1.95 2.3-5.5					0.25V _{CC} 0.30V _{CC}		0.25V _{CC} 0.30V _{CC}	
V _{OH}	HIGH Level Output Voltage	1.65	V _{IN} = V _{IH}	I _{OH} = -100μA	1.55	1.65		1.55		V
		1.8			1.7	1.79		1.9		
		2.3			2.2	2.29		2.4		
		3.0			2.	2.99		2.3		
		4.5			4.4	4.5		4.4		
		1.65		I _{OH} = -4mA	1.29	1.52		1.29		
		2.3		I _{OH} = -8mA	1.9	2.13		1.9		
		3.0		I _{OH} = -16mA	2.4	2.71		2.4		
		3.0		I _{OH} = -24mA	2.3	2.55		2.3		
		4.5		I _{OH} = -32mA	3.8	4.20		3.8		
V _{OL}	LOW Level Output Voltage	1.65	V _{IN} = V _{IL}	I _{OL} = 100μA		0.01	0.1		0.1	μA
		1.8				0.01	0.1		0.1	
		2.3				0.01	0.1		0.1	
		3.0				0.00	0.1		0.1	
		4.5				0.00	0.1		0.1	
		1.65		I _{OL} = 4mA		0.08	0.24		0.24	
		2.3		I _{OL} = 8mA		0.10	0.3		0.3	
		3.0		I _{OL} = 16mA		0.18	0.4		0.4	
		3.0		I _{OL} = 24mA		0.28	0.55		0.55	
		4.5		I _{OL} = 32mA		0.28	0.55		0.55	
I _{IN}	Input Leakage Current	0-5.5	V _{IN} = 5.5V, GND		-1		1	-1	1	
I _{OFF}	Power Off Leakage Current	0.0	V _{IN} or V _{OUT} = 5.5V		-1		1	-1	1	
I _{CC}	Quiescent Supply Current	1.65-5.5	V _{IN} = 5.5V, GND				2.0		20	

AC Electrical Characteristics

Symbol	Parameter	V _{CC} (V)	Conditions	T _A = +25°C			T _A = -40 to +85°C		Units	Fig. No.
				Min.	Typ.	Max.	Min.	Max.		
t _{PLH} , t _{PHL}	Propagation Delay	1.8 ±0.15	C _L = 15pF, R _D = 1M-ohm, S ₁ = Open	0.7	5.4	6.4	0.7	7.1	ns	1
		2.5 ±0.2		0.5	3.3	4.1	0.5	4.5		
		3.3 ±0.3		0.5	2.7	3.3	0.5	3.6		
		5.0 ±0.5		0.5	2.2	2.7	0.5	3.0		
t _{PLH} , t _{PHL}	Propagation Delay	3.3 ±0.3	C _L = 50pF, R _D = 500-ohms, S ₁ = Open	0.5	3.7	4.4	0.5	4.8		1
		5.0 ±0.5		0.5	3.1	3.7	0.5	4.1		
t _{PZL} , t _{PZH}	Output Enable Time	1.8 ±0.15	C _L = 50pF, R _D = 500-ohms, R _U = 500-ohms, S ₁ = GND for t _{PZH} S ₁ = V _{IN} for t _{PZL} V _{IN} = 2 x V _{CC}	2	8.1	12.2	2	13.4		1
		2.5 ±0.2		1.5	4.5	7.4	1.5	8.1		
		3.3 ±0.3		1.5	3.3	4.4	1.5	4.8		
		5.0 ±0.5		0.8	2.4	3.5	1.5	3.9		
t _{PLZ} , t _{PHZ}	Output Disable Time	1.8 ±0.15	C _L = 50pF, R _D = 500-ohms, R _U = 500-ohms, S ₁ = GND for t _{PHZ} S ₁ = V _{IN} for t _{PLZ} V _{IN} = 2 x V _{CC}	2	6.8	10.2	2	11.2		1
		2.5 ±0.2		1.5	4.4	4.9	1.5	5.4		
		3.3 ±0.3		1.0	3.3	3.8	1.5	4.2		
		5.0 ±0.5		0.8	2.4	3.1	1.5	3.4		
C _{IN} , C _{OUT}	Input Capacitance Output Capacitance	V _{IN} = 0 V _{OUT} = 0		4 8				pF		
C _{PD}	Power Dissipation Capacitance ⁽³⁾	3.3 5.0		17 19					2	

Notes:

3. C_{PD} is defined as the value of the internal equivalent capacitance which is derived from dynamic operating current consumption (I_{CCD}) at no output loading and operating at 50% duty cycle (see Figure 2). C_{PD} is related to I_{CCD} dynamic operating current by the expression: I_{CCD} = (C_{PD})(V_{CC})(f_{IN}) + (I_{CC} static).

AC Loading and Waveforms

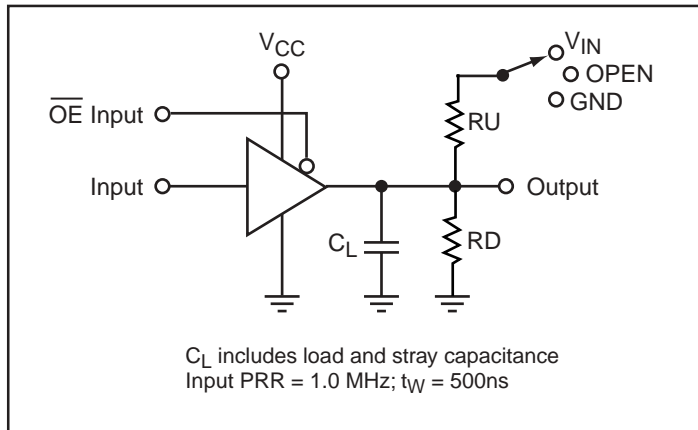

Figure 1. AC Test Circuit

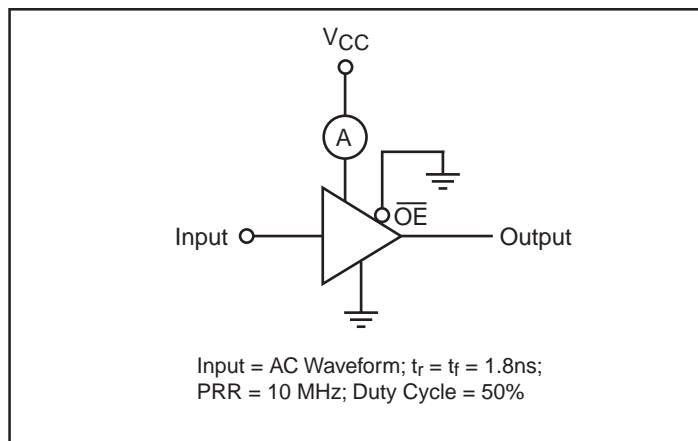

Figure 2. ICCD Test Circuit

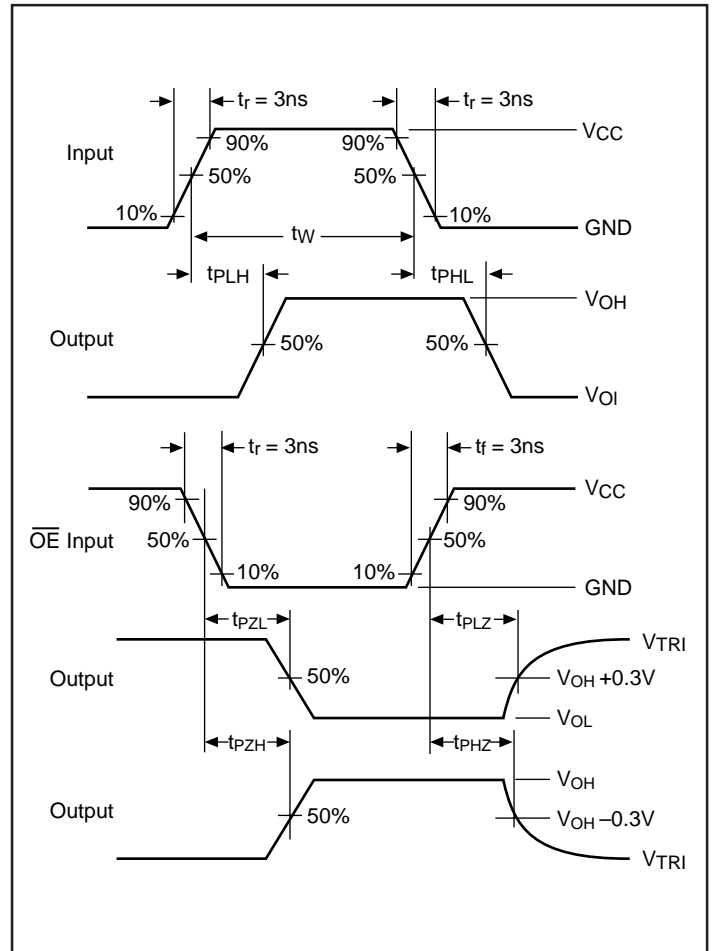
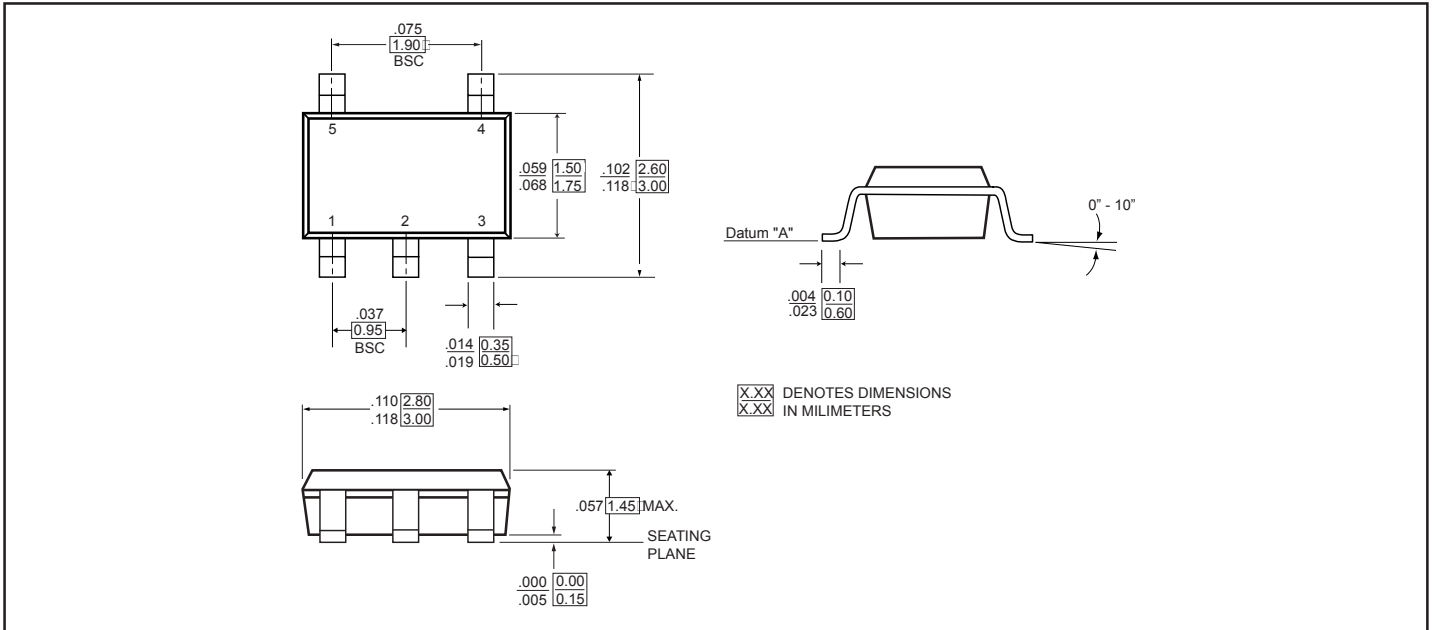
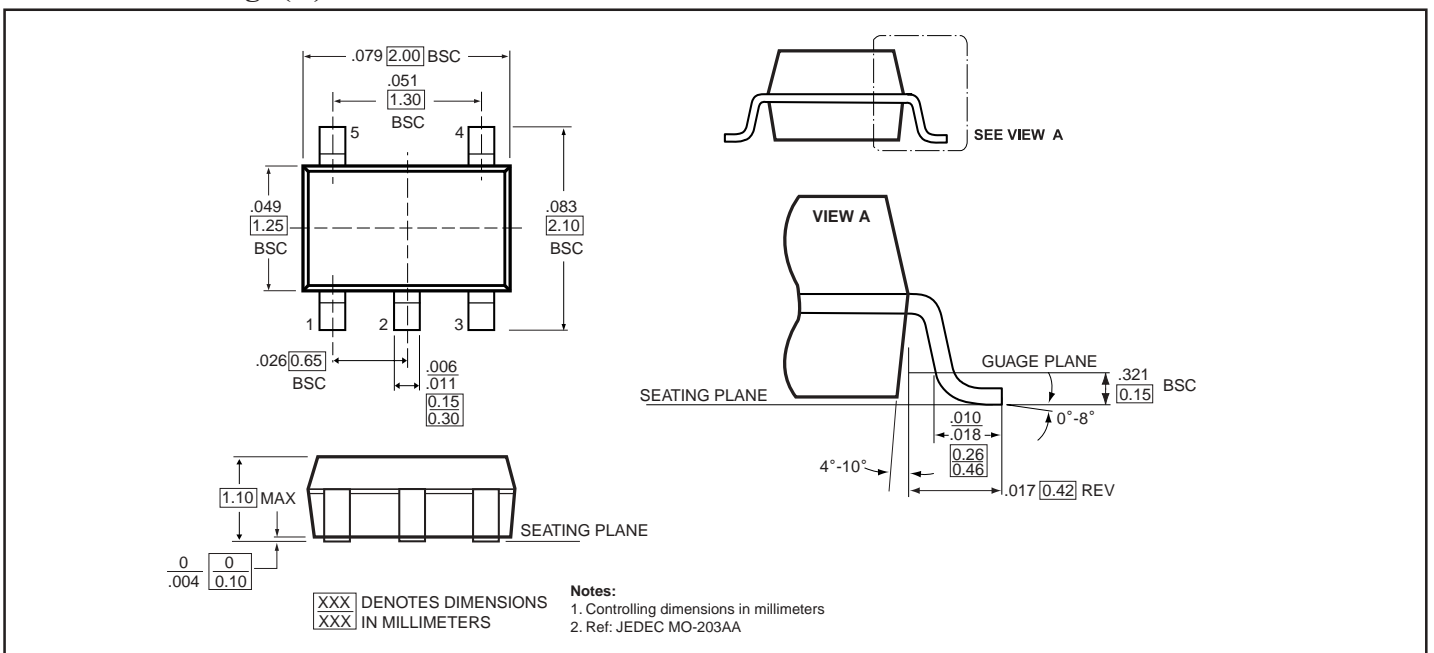

Figure 3. AC Waveforms

5-Pin SOT23 (T) Package



5-Pin SC70 Package (C)



Ordering Information

Part	Pin-Package	Top Marking	Operating Range
PI74STX1G125TX	5-Pin - SOT23	M7D	-40°C to 85°C
PI74STX1G125CX	5-Pin - SC70	M7D	-40°C to 85°C