

Fast CMOS 3.3V 16-Bit Buffer/Line Driver

Features

- Functionally compatible with FCT3, LVT, and 74 series 16244 families of products
- 3-State outputs
- 5V Tolerant inputs and outputs
- 2.0V-3.6V Vcc supply operation
- Balanced sink and source output drives (24mA)
- Low ground bounce outputs
- Power Down High Impedance inputs and outputs
- Supports live insertion
- ESD Protection exceeds 2000V, Human Body Model  
200V, Machine Model
- Packages available:
  - 48-pin 240-mil wide plastic TSSOP (A)
  - 48-pin 300-mil wide plastic SSOP (V)

Description

Pericom Semiconductor's PI74LCX16244 is a 16-bit buffer/line driver designed for driving memory loads. With its balanced-drive characteristics, this high-speed, low power device provides lower ground bounce, transmission line matching of signals, fewer line reflections and lower EMI and RFI effects. This makes it ideal for driving on-board buses and transmission lines. This device is designed with three-state controls to operate in a Quad-Nibble, Dual-Byte, or a single 16-bit word mode.

The PI74LCX16244 can be driven from either 3.3V or 5.0V devices allowing this device to be used as a translator in a mixed 3.3V/5.0V system.

Block Diagram

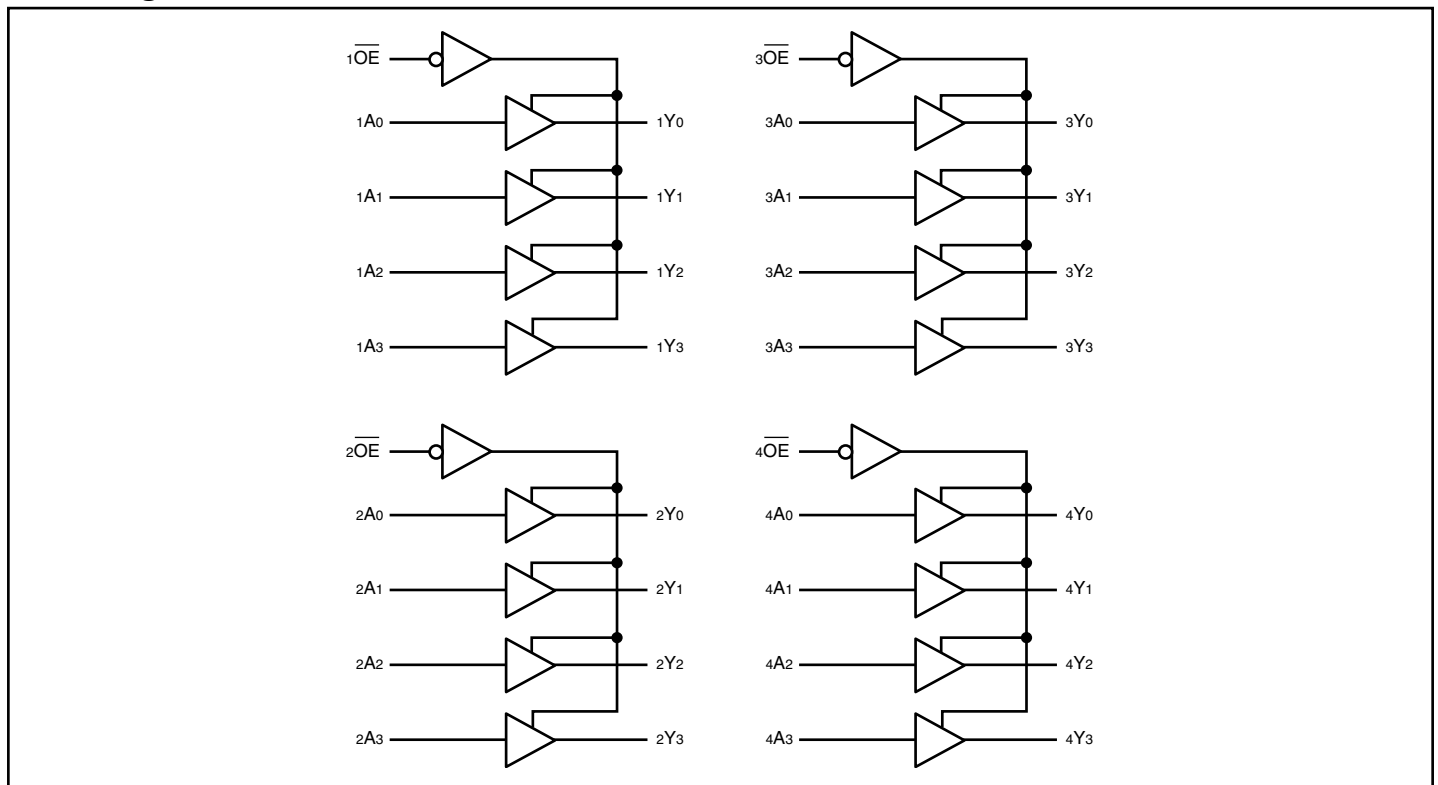

### Maximum Ratings

(Above which the useful life may be impaired. For user guidelines, not tested.)

Storage Temperature .....	-65°C to +150°C
Ambient Temperature with Power Applied .....	-40°C to +85°C
Supply Voltage to Ground Potential (Inputs & V <sub>CC</sub> Only).....	-0.5V to +7.0V
Supply Voltage to Ground Potential (Outputs & D/O Only) ...	-0.5V to +7.0V
DC Input Voltage .....	-0.5V to +7.0V
DC Output Current.....	120 mA
Power Dissipation .....	1.0W

**Note:**

Stresses greater than those listed under MAXIMUM RATINGS may cause permanent damage to the device. This is a stress rating only and functional operation of the device at these or any other conditions above those indicated in the operational sections of this specification is not implied. Exposure to absolute maximum rating conditions for extended periods may affect reliability.

### Recommended Operating Conditions

Parameter	Description		Min.	Max.	Units
V <sub>CC</sub>	Supply Voltage	Operating	2.0	3.6	V
		Data Retention	1.5	3.6	
V <sub>I</sub>	Input Voltage		0	5.5	
V <sub>O</sub>	Output Voltage	HIGH or LOW state	0	V <sub>CC</sub>	
		3-state	0	5.5	
I <sub>OH</sub> /I <sub>OL</sub>	Output Current	V <sub>CC</sub> = 3.0V - 3.6V		±24	mA
		V <sub>CC</sub> = 2.7V		±12	
T <sub>A</sub>	Operating Temperature		-40	85	°C
Δt/ΔV	Input Edge Rate	V = 0.8V - 2.0V, V <sub>CC</sub> = 3.0V	0	10	ns/V

**Pin Description**

Pin Name	Description
$\overline{xOE}$	3-State Output Enable Inputs (Active LOW)
$xAX$	Inputs
$xYX$	3-State Outputs
GND	Ground
V <sub>CC</sub>	Power

**Truth Table<sup>(1)</sup>**

Inputs		Output
$\overline{xOE}$	$xAX$	$xYX$
L	L	L
L	H	H
H	X	Z

**Note:**

- H = High Voltage Level, X = Don't Care,  
L = Low Voltage Level, Z = High Impedance

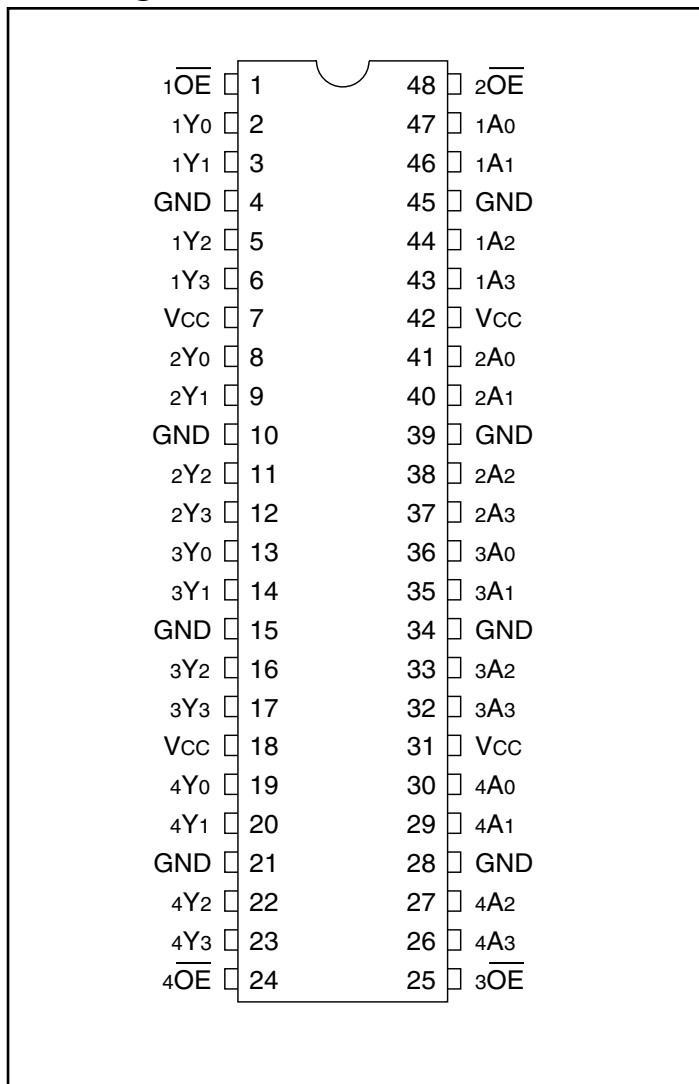
**Pin Configuration**

**DC Electrical Characteristics** (Over the Operating Range,  $T_A = -40^\circ\text{C}$  to  $+85^\circ\text{C}$ ,  $V_{CC} = 2.7\text{V}$  to  $3.6\text{V}$ )

Parameters	Description	Test Conditions <sup>(1)</sup>		Min.	Typ.	Max.	Units
V <sub>IH</sub>	Input HIGH Voltage	Guaranteed Logic HIGH Level		2.0			V
V <sub>IL</sub>	Input LOW Voltage	Guaranteed Logic LOW Level				0.8	
V <sub>OH</sub>	Output HIGH Voltage	V <sub>CC</sub> = 2.7 - 3.6	I <sub>OH</sub> = -0.1mA	V <sub>CC</sub> - 0.2			
		V <sub>CC</sub> = 2.7	I <sub>OH</sub> = -12mA	2.2			
		V <sub>CC</sub> = 3.0	I <sub>OH</sub> = -18mA	2.4			
			I <sub>OH</sub> = -24mA	2.2			
V <sub>OL</sub>	Output LOW Voltage	V <sub>CC</sub> = 2.7 - 3.6	I <sub>OL</sub> = 0.1mA			0.2	
		V <sub>CC</sub> = 2.7	I <sub>OL</sub> = 12mA			0.4	
		V <sub>CC</sub> = 3.0	I <sub>OL</sub> = 16mA			0.4	
			I <sub>OL</sub> = 24mA			0.55	
V <sub>IK</sub>	Clamp Diode Voltage	V <sub>CC</sub> = Min., I <sub>IN</sub> = -18mA			-0.7	-1.2	
II	Input Leakage Current	0 ≤ V <sub>I</sub> ≤ 5.5V	V <sub>CC</sub> = 2.7 - 3.6			±5	μA
IOZ	Tri-State Output Leakage	0 ≤ V <sub>O</sub> ≤ 5.5V V <sub>I</sub> = V <sub>IH</sub> or V <sub>IL</sub>	V <sub>CC</sub> = 2.7 - 3.6			±5	
IOFF	Power Down Disable	V <sub>CC</sub> = 0V, V <sub>IN</sub> or V <sub>OUT</sub> ≤ 5.5V				10	
ICC	Quiescent Power supply current	V <sub>CC</sub> = Max.	V <sub>IN</sub> = GND or V <sub>CC</sub>		0.1	10	
ΔICC	Quiescent Power supply current TTL Inputs High	V <sub>CC</sub> = Max.	V <sub>IN</sub> = V <sub>CC</sub> = 0.6V <sup>(3)</sup>			500	

**Notes:**

- For Max. or Min. conditions, use appropriate value specified under Electrical Characteristics for the applicable device type.
- Typical values are at V<sub>CC</sub> = 3.3V, +25°C ambient.
- Per TTL driven input; all other inputs at V<sub>CC</sub> or GND.

**Capacitance**

Parameters	Description	Test Conditions	Typ.	Units
C <sub>IN</sub>	Input Capacitance	V <sub>CC</sub> = Open, V <sub>I</sub> = 0V or V <sub>CC</sub>	3	pF
C <sub>OUT</sub>	Output Capacitance	V <sub>CC</sub> = 3.3V, V <sub>I</sub> = 0V or V <sub>CC</sub>	3	
C <sub>PD</sub>	Power Dissipation Capacitance	V <sub>CC</sub> = 3.3V, V <sub>I</sub> = 0V or V <sub>CC</sub> , F = 10 MHz	20	

**Switching Characteristics over Operating Range**

Parameters	Description	Test Conditions	V <sub>CC</sub> = 3.3V±0.3		V <sub>CC</sub> = 2.7V		Units
			Min.	Max.	Min.	Max.	
t <sub>PHL</sub>	Propagation Delay, D <sub>XX</sub> to O <sub>XX</sub>	C <sub>L</sub> = 50pF R <sub>L</sub> = 500Ω	1.5	4.5	1.5	5.2	ns
t <sub>PZH</sub>	Output Enable time		1.5	5.5	1.5	6.3	
t <sub>PHZ</sub>	Output Disable time		1.5	5.4	1.5	5.7	
t <sub>sk(0)</sub>	Output Skew <sup>(1)</sup>			1.0			

**Note:**

1. Skew between any two outputs, of the same package, switching in the same direction.

**Dynamic Switching Characteristics (T<sub>A</sub> = +25°C)**

Parameters	Description	Test Conditions <sup>(1)</sup>	Typ.	Units
V <sub>OLP</sub>	Dynamic LOW peak voltage	V <sub>CC</sub> = 3.3V, C <sub>L</sub> = 50pF, V <sub>IH</sub> = 3.3V, V <sub>IL</sub> = 0V	0.8	V
V <sub>OLV</sub>	Dynamic LOW valley voltage			

**Note:**

1. Measured with 15 outputs switching from High-to-Low or Low-to-High. The remaining output is measured in the LOW state.

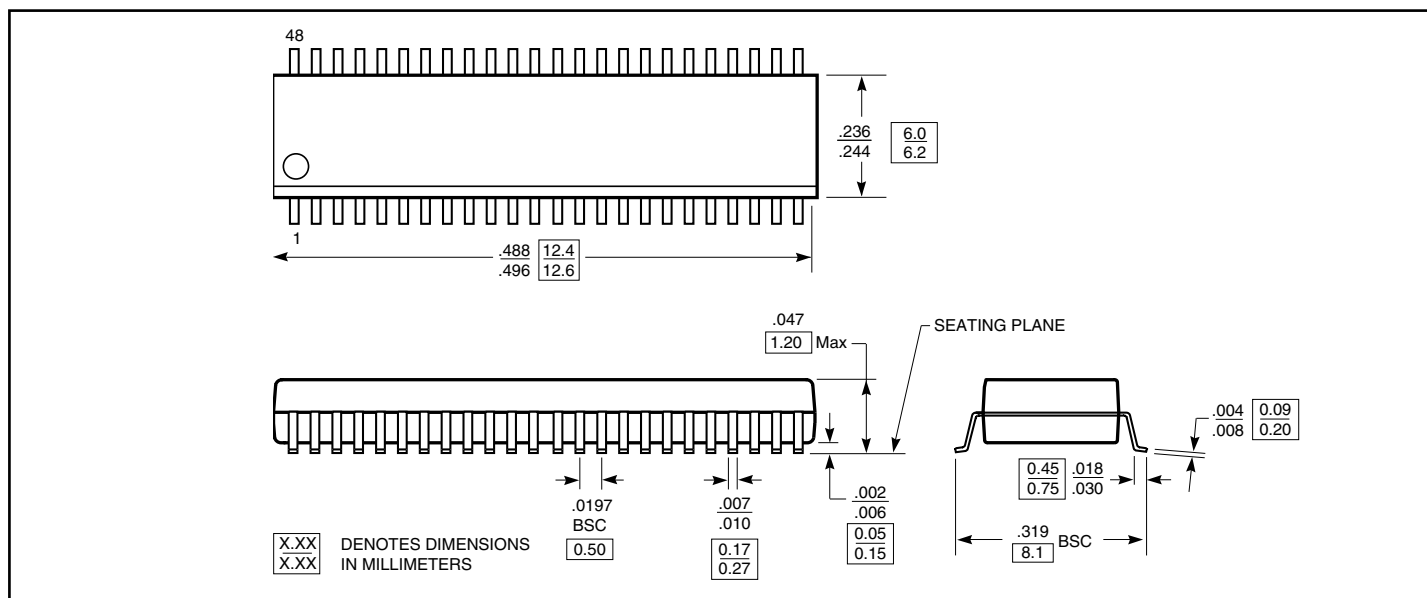
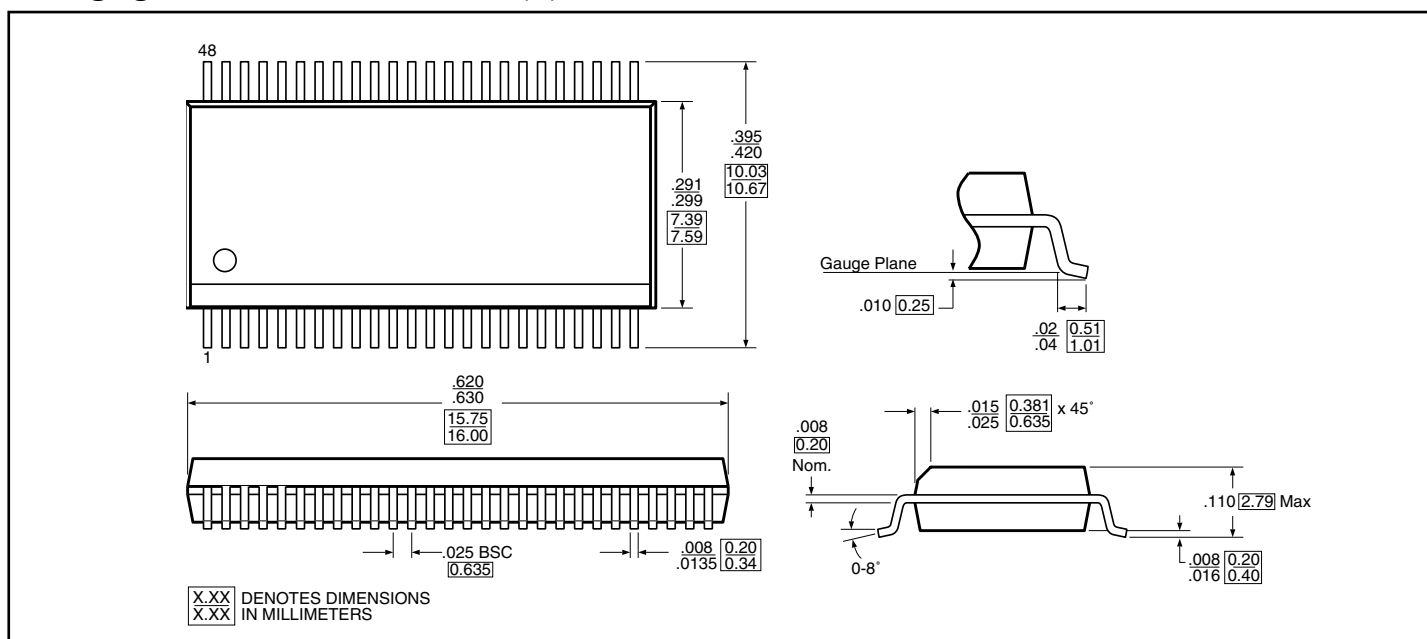
**Packaging Mechanical: 48-Pin TSSOP (A)**

**Packaging Mechanical: 48-Pin SSOP (V)**

**Ordering Information**

Ordering Code	Package Code	Package Description
PI74LCX16244A	A	48-pin 240-mil wide plastic TSSOP
PI74LCX16244V	V	48-pin 300-mil wide plastic SSOP

**Notes:**

1. Thermal characteristics can be found on the web at [www.pericom.com/packaging/](http://www.pericom.com/packaging/)