

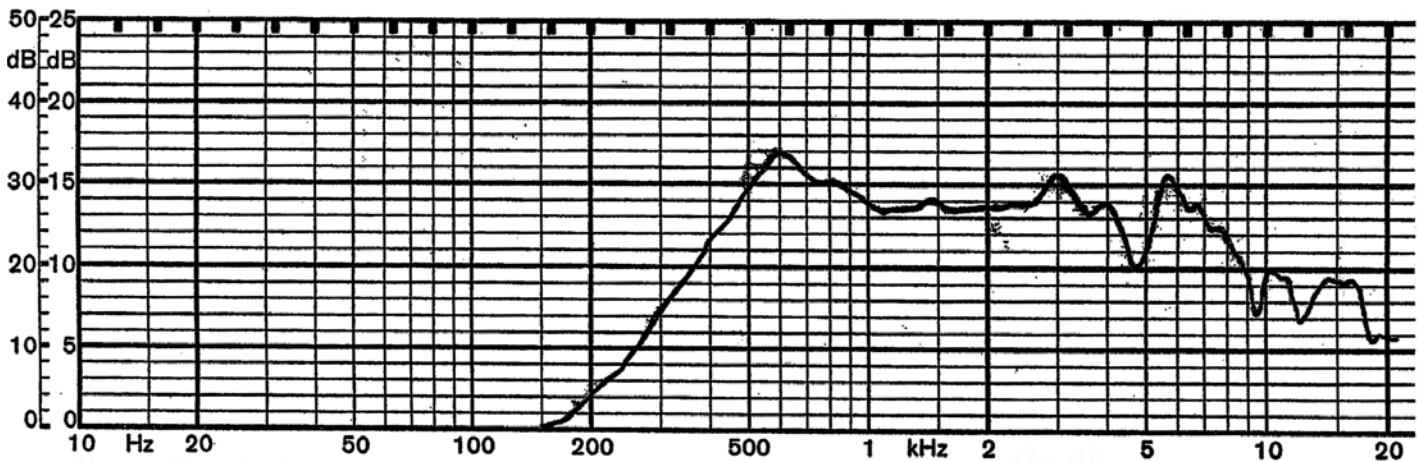

**Specifications**

Nominal Size	87 mm (3.25 in)	(See attached drawing)
Impedance	8 Ohm $\pm$ 15%	at 800 Hz 1 V
Resonant frequency	580 Hz $\pm$ 116 Hz	at 1 V
Sound pressure level	97 dB/w $\pm$ 3 dB	1 w 50 cm ave. at 1.0K, 1.3K, 1.6K, 2.0K Hz
Response	Fo Hz ~ 18 KHz max 10 dB	
Input power	Nominal 12 W	Handling capacity 15 W
Operation	must be normal at program source 12 W	
Buzz, rattle, etc.	must be normal at sine wave 9.8 V	
Magnet	Size: 60 x 32 x 8 mm	
Load test	White noise 12 W	for 48 hours
Heat test	70 $\pm$ 2° C	20-50% R.H. 48 hours
Humidity test	40 $\pm$ 2° C	90-95% R.H. 48 hours

**Frequency Response Curve**

Potentiometer range	50 dB
Rectifier	RMS
Lower limit frequency	20 Hz
Wr. speed	100 mm/sec



Zero level 60 dB

REV.	DESCRIPTION	DATE
A	NEW DRAWING	8/8/2006

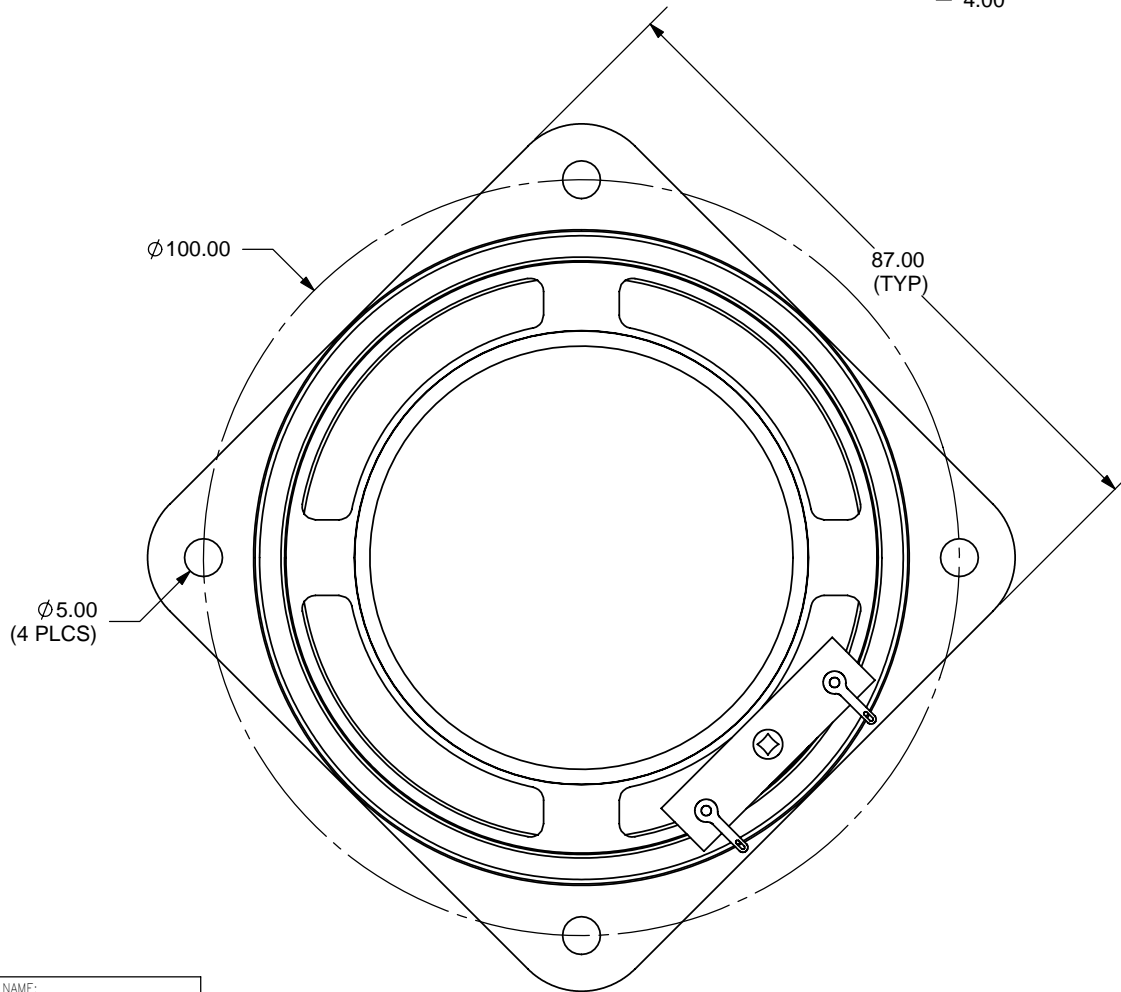
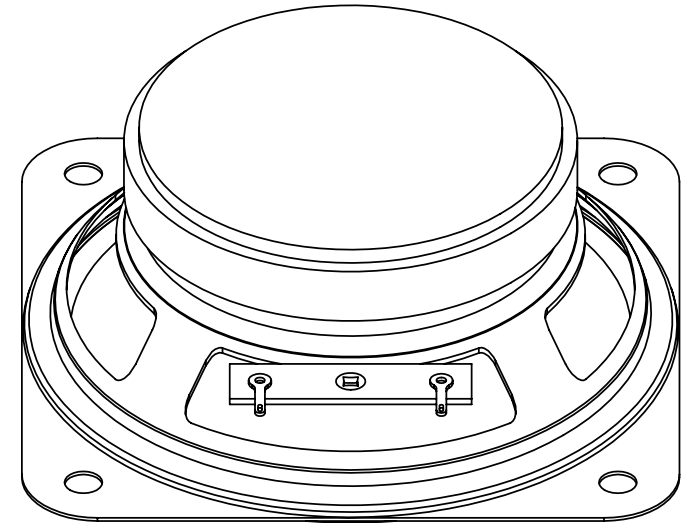
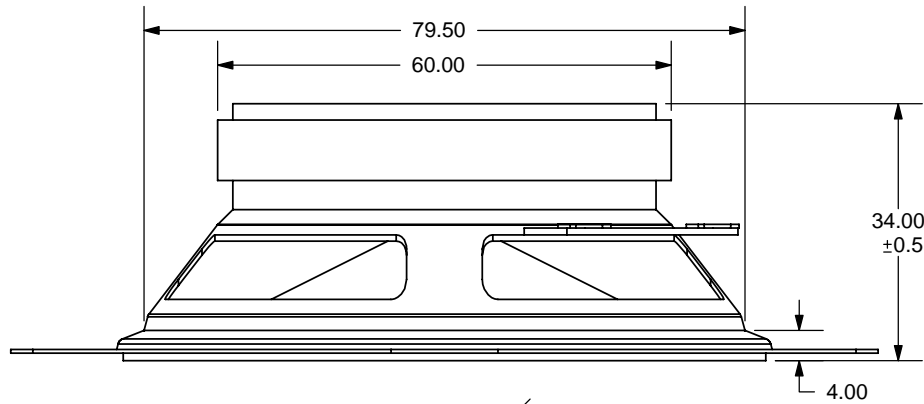

TOLERANCE:  
±0.5mm UNLESS OTHERWISE  
SPECIFIED



20050 SW 112th Ave.  
Tualatin, OR 97062  
Phone: 503-643-4899  
800-275-4899  
Fax: 503-372-1266  
Website: www.cui.com

TITLE: Square frame paper cone - ferrite magnet		REV: A
PART NO. GF0876M	UNITS: MM [INCHES]	
DRAWN BY: ZRJ	APPROVED BY:	SCALE: 1:1

PC FILE NAME:  
GF0876M

COPYRIGHT 2006 BY CUI INC.