

# Crystal Clear Technology

## Product Specification

### **C216x05 series**

Crystal Clear Technology sdn. bhd.

16Jalan TP5—Taman Perindustrian Sime UEP  
47600 Subang Jaya—Selangor DE  
Malaysia. T: +603 80247099 F: +603 80247098

---



1.0 Table of Contents

	Page
1. Table of Contents	1
2. Record of revision	2
3. General specification	3
4. Absolute maximum ratings	4
5. Electrical characteristics	4
6. Environmental requirement	4
7. LCD specification	5 ~ 7
8. Interface	8
9. Timing characteristics / Timing diagrams	9 ~ 11
10. Power supply	12
11. Block diagram	12
12. Instructions	13 ~ 16
13. Quality assurance	17 ~ 18
14. Precautions in use LCM	19 ~ 20
15. Outline drawing	21



2.0 Record of revision

Rev	Date	Item	Page	Comment	Originator	Checked By
1.0	04/06/08			Initial Release	Syam	Azhar



3.0 General specification

Display format: Characters 2 x 16

Character size: 5 x 8

Character size: 5.20mm x 9.55mm

View area: 99.0mm x 24.0mm

Active area: 95.2mm x 20.0mm

General dimensions: 122.0mm x 44.0mm

Controller/Driver: ST7066U-0A-B and ST7065C-B or equivalent

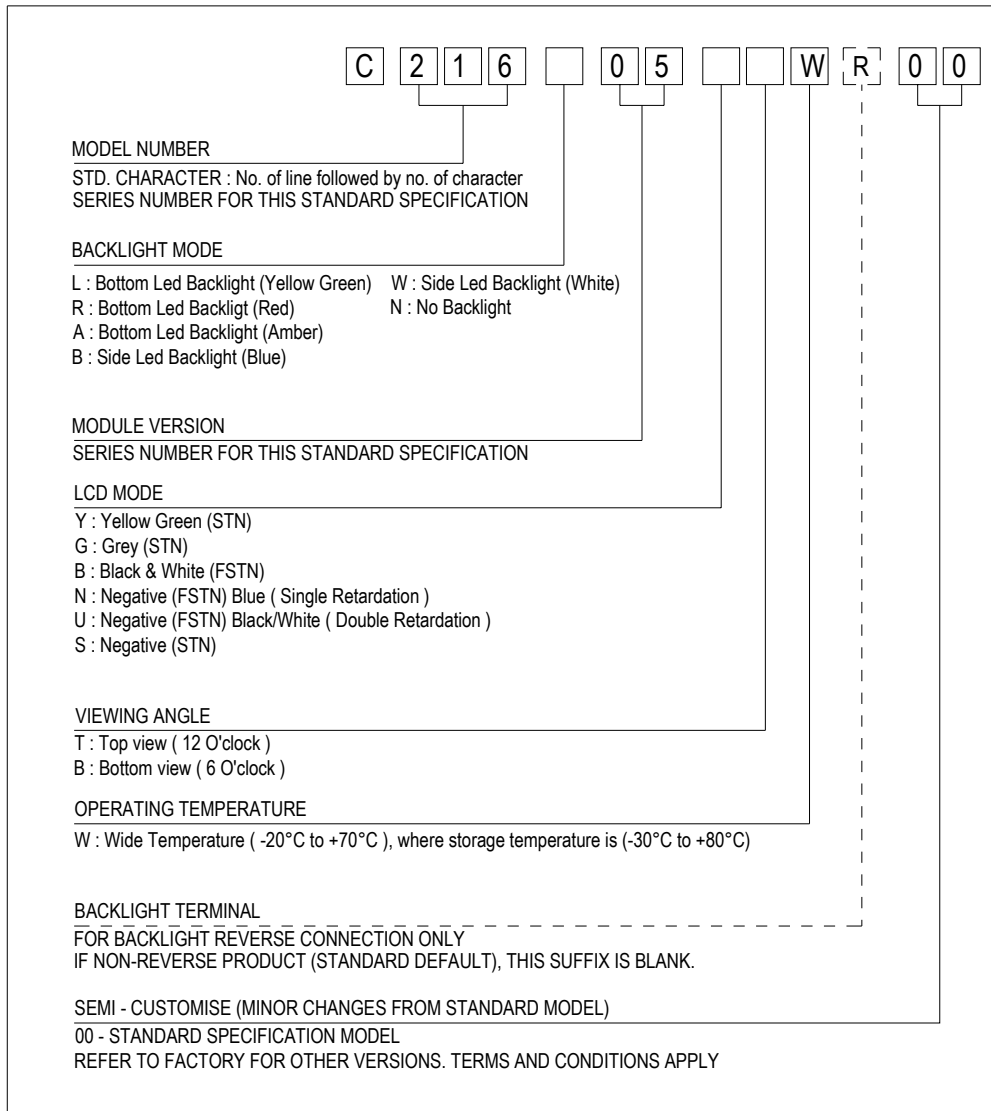

**4.0 Absolute maximum rating (at V<sub>SS</sub> = 0V, ambient temperature = 25°C)**

NO	ITEM	SIMBOL	MIN	MAX	UNIT
1.	Power Supply voltage (Logic)	V <sub>DD</sub> - V <sub>SS</sub>	0	7	V
2.	Power Supply voltage (LCD Driver)	V <sub>DD</sub> - V <sub>0</sub>	-	12	V
3.	Operating Temperature	T <sub>op</sub>	Refer page 3		°C
4.	Storage Temperature	T <sub>st</sub>	Refer page 3		°C

**5.0 Electrical characteristics**

NO	ITEM	SYMBOL	CONDITION	MIN	TYP	MAX	UNIT
1.	Power Supply voltage (Logic)	V <sub>DD</sub> - V <sub>SS</sub>	-	4.5	5.0	5.5	V
2.	Power Supply voltage (V <sub>LCD</sub> )	V <sub>DD</sub> - V <sub>0</sub>	25°C	4.5±5%			V
3.	Input Voltage (except OSC1)	V <sub>IH</sub>	-	0.7V <sub>dd</sub>	-	V <sub>dd</sub>	V
		V <sub>IL</sub>	-	-0.3	-	0.6	V
4.	Current Supply	I <sub>DD</sub>	V <sub>DD</sub> - V <sub>SS</sub> = 5V	-	1.0	2.0	mA

**5.1 Backlight Options**

NO	COLOR	FORWARD VOLTAGE (V)			FORWARD CURRENT (mA)			MIN BRIGHTNESS (cd/m <sup>2</sup> ) *
		Min	Typ.	Max	Min	Typ.	Max	
1.	Yellow Green	-	5.0	-	-	110	150	60
2.	White	-	4.5	-	-	35	40	160
3.	Blue	-	5.0	-	-	35	40	70
4.	Amber	-	5.0	-	-	120	150	170
5.	Red	-	5.0	-	-	120	150	170

- \*Note : 1. Brightness measured at backlight surface.  
 2. On LCD surface, brightness is only about 10% to 15% of backlight brightness.  
 3. Lifetime of backlight: For YG, Amber, Red = 50K hrs. For White, Blue = 20K hrs

**6.0 Environmental requirements**

NO	ITEM	CONDITION
1.	Operating Temperature	Refer page 3
2.	Storage Temperature	Refer page 3
3.	Operating Humidity	5% to 95%RH
4.	Cycle Test	0 C @ 30 min to 50 C @ 30min for 1 cycle run for 10 cycles
5.	Lifetime	50000 HOURS (excluding backlight)

Note: The background on LCD has the possibility to be changed in different temperature range.



## 7.0 LCD specification

## 7.1 Electro-optical characteristics (at ambient temperature = 25°C)

NO	ITEM	SYMBOL	CONDITION	LCD TYPE						REF.
				STN YG	STN GREY	STN -VE BLUE	FSTN +VE B/W	FSTN -VE BLUE	FSTN -VE TRUE B/W	
1	Operating Voltage (Volt)	$V_{LCD}$	$\theta = 0$ $Cr = \max$	4.5 ± 5%						7.1.1
2	Viewing Angle (Deg)	$\theta x 1$	$CR \geq 2$ $V_{LCD} = 4.5V$	+25	+20	+35	+25	+35	+35	7.1.2
		$\theta x 2$		-25	-20	-35	-25	-35	-40	
		$\theta y 1$		-30	-25	-35	-30	-35	-35	
		$\theta y 2$		+30	+25	+35	+30	+35	+35	
3	Contrast Ratio	CR	$\theta = 0^0$ $V_{LCD} = 4.5V$	3.0	2.3	6.0	3.0	6.0	20	7.1.3
4	Response Time (msec)	Rise Time (Tr)	$\theta = 0^0$	200						7.1.4
		Decay Time (Td)	$\theta = 0^0$	250						

## Note:

1. Viewing angle data is based on bottom view product by default. Should it be a top view product, values are then swap.
2. Contrast ratio is based on typical data when using white colour as backlight.
3. Equipment Used Eldim; Ez Contrast 120R , Spot Size = 2mm

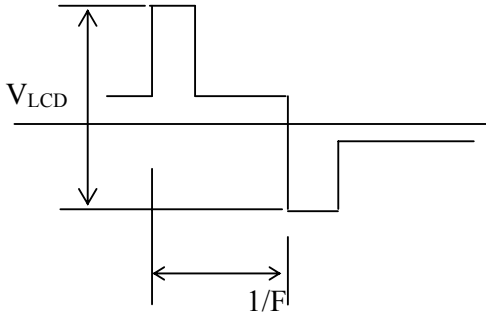
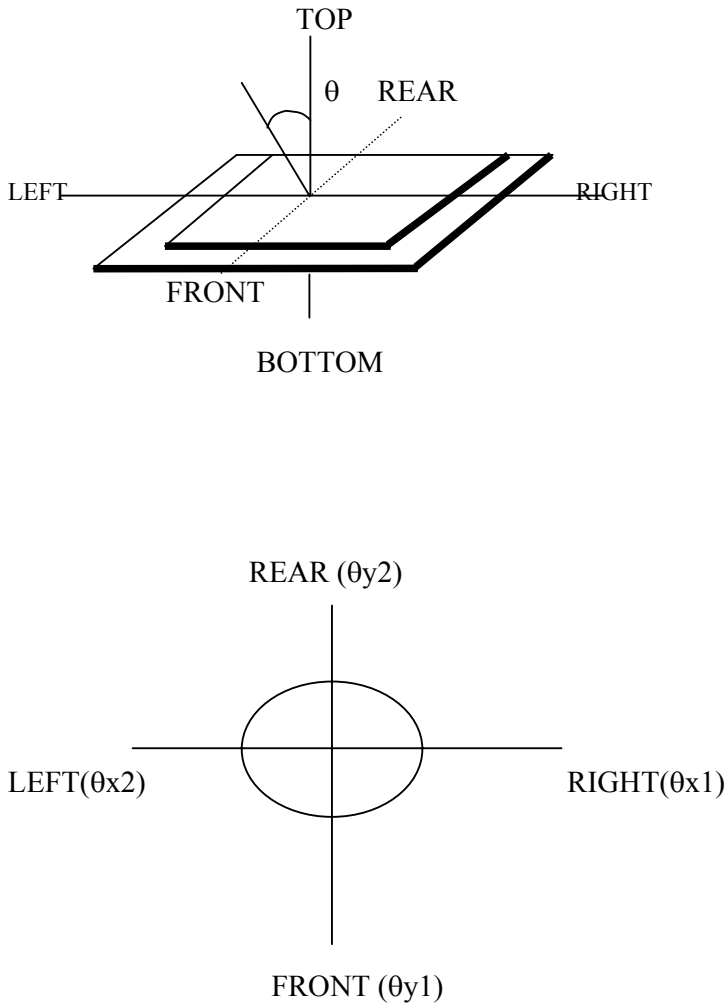

NO	CHARACTERISTICS	DEFINITIONS
7.1.1	<b>Definition of Operating Voltage (<math>V_{LCD}</math>)</b>	 <p><math>V_{LCD}</math> : Operating Voltage F : Frame Frequency</p>
7.1.2	<b>Definition of Viewing Angle</b>	 <p>TOP <math>\theta</math> REAR LEFT RIGHT FRONT BOTTOM</p> <p>REAR (<math>\theta_{y2}</math>) LEFT(<math>\theta_{x2}</math>) RIGHT(<math>\theta_{x1}</math>) FRONT (<math>\theta_{y1}</math>)</p>

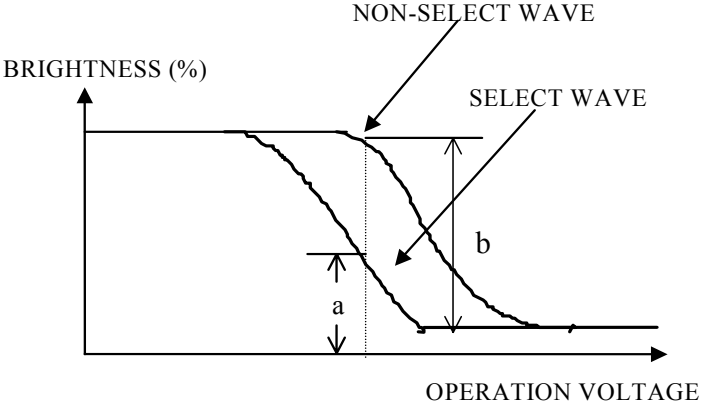
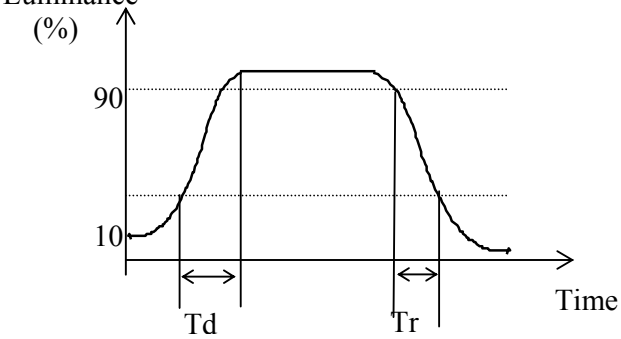

<p>7.1.3</p>	<p><b>Definition of Contrast Ratio</b></p>	 <p>Contrast Ratio = <math>\frac{\text{Brightness of non-selected state (b)}}{\text{Brightness of selected state (a)}}</math></p> <p><b>Conditions</b></p> <ul style="list-style-type: none"><li>(a) Operating Voltage: <math>V_{LCD}</math></li><li>(b) Temperature: <math>25^{\circ}C</math></li><li>(c) Viewing Angle, <math>\theta = 0^{\circ}</math></li></ul>
<p>7.1.4</p>	<p><b>Response Time</b></p>	 <p><math>T_r</math>: Measured between 10% and 90% of LCD segment maximum response with <math>V_{ON}</math>.</p> <p><math>T_d</math>: With voltage switches to zero and the instant LCD segment reaches 10% of its maximum response.</p>



**8.0 Interface**

<b>8.1</b>	<b>Display Driver</b>	ST7066U and ST7065	
<b>8.2</b>	<b>Duty Cycle</b>	1/16	
<b>8.3</b>	<b>Pin-out Assignments</b>		
	<b>Pin No</b>	<b>Symbol</b>	<b>Description</b>
	1	V <sub>SS</sub>	Ground terminal of module
	2	V <sub>DD</sub>	Supply terminal of module
	3	V <sub>O</sub>	Power supply for Liquid Crystal Drive
	4	RS	Register Select: RS = 0 .... Instruction Register RS = 1 .... Data Register
	5	R/W	Read/Write: High = Read Low = Write
	6	E	Enable
	7 to 14	D0 to D7	Bi-directional Data Bus. Data Transfer is performed once, thru D0 to D7, in the case of interface data length is 8-bits.
	15	(BL -)	LED power supply terminals
	16	(BL +)	



9.0 Timing characteristics / Timing diagrams

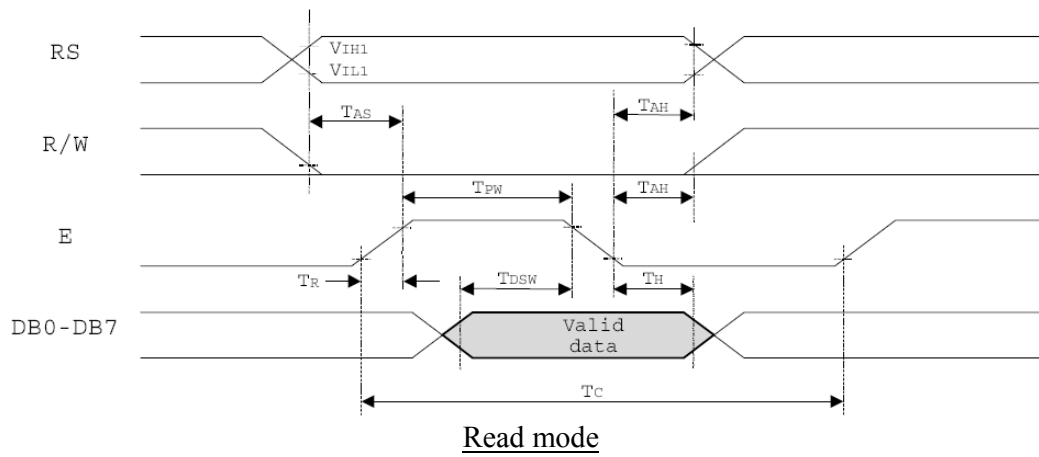
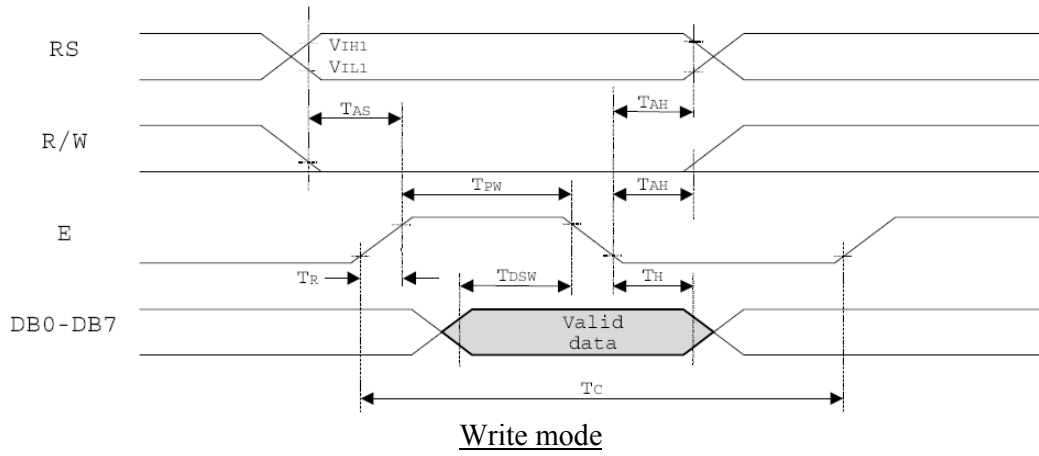



Symbol	Characteristics	Test Condition	Min.	Typ.	Max.	Unit
<i>Internal Clock Operation</i>						
f <sub>OSC</sub>	OSC Frequency	R = 91KΩ	190	280	350	KHz
<i>External Clock Operation</i>						
f <sub>EX</sub>	External Frequency	-	125	280	350	KHz
	Duty Cycle	-	45	50	55	%
T <sub>R</sub> , T <sub>F</sub>	Rise/Fall Time	-	-	-	0.2	μs
<i>Write Mode (Writing data from MPU to ST7066)</i>						
T <sub>C</sub>	Enable Cycle Time	Pin E	1200	-	-	ns
T <sub>PW</sub>	Enable Pulse Width	Pin E	140	-	-	ns
T <sub>R</sub> , T <sub>F</sub>	Enable Rise/Fall Time	Pin E	-	-	25	ns
T <sub>AS</sub>	Address Setup Time	Pins: RS,RW,E	0	-	-	ns
T <sub>AH</sub>	Address Hold Time	Pins: RS,RW,E	10	-	-	ns
T <sub>DSW</sub>	Data Setup Time	Pins: DB0 - DB7	40	-	-	ns
T <sub>H</sub>	Data Hold Time	Pins: DB0 - DB7	10	-	-	ns
<i>Read Mode (Reading Data from ST7066 to MPU)</i>						
T <sub>C</sub>	Enable Cycle Time	Pin E	1200	-	-	ns
T <sub>PW</sub>	Enable Pulse Width	Pin E	140	-	-	ns
T <sub>R</sub> , T <sub>F</sub>	Enable Rise/Fall Time	Pin E	-	-	25	ns
T <sub>AS</sub>	Address Setup Time	Pins: RS,RW,E	0	-	-	ns
T <sub>AH</sub>	Address Hold Time	Pins: RS,RW,E	10	-	-	ns
T <sub>DDR</sub>	Data Setup Time	Pins: DB0 - DB7	-	-	100	ns
T <sub>H</sub>	Data Hold Time	Pins: DB0 - DB7	10	-	-	ns
<i>Interface Mode with LCD Driver(ST7065)</i>						
T <sub>CWH</sub>	Clock Pulse with High	Pins: CL1, CL2	800	-	-	ns
T <sub>CWL</sub>	Clock Pulse with Low	Pins: CL1, CL2	800	-	-	ns
T <sub>CST</sub>	Clock Setup Time	Pins: CL1, CL2	500	-	-	ns
T <sub>SU</sub>	Data Setup Time	Pin: D	300	-	-	ns
T <sub>DH</sub>	Data Hold Time	Pin: D	300	-	-	ns
T <sub>DM</sub>	M Delay Time	Pin: M	-1000	-	1000	ns

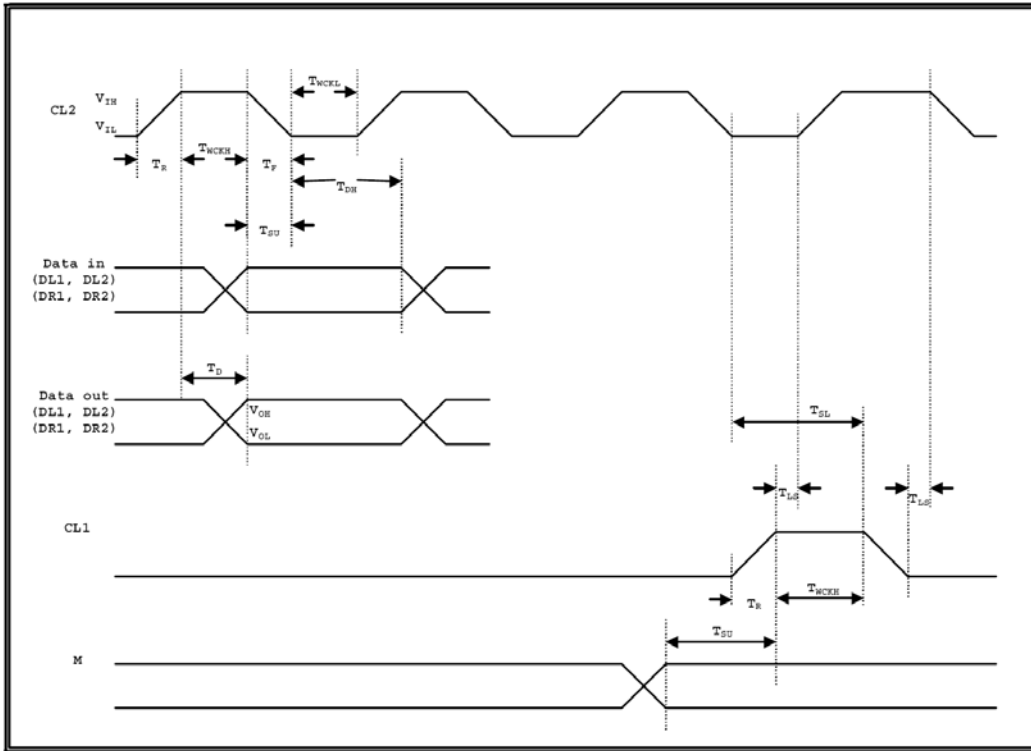

Interface with extension driver

Symbol	Parameter	Test Condition	Min.	Max.	Unit	Applicable pin
FCL	Data Shift Frequency	-	-	400	KHZ	CL2
TWCKH	Clock High Level Width	-	800	-	ns	CL1,CL2
TWCKL	Clock Low Level Width	-	800	-	ns	CL2
TSL	Clock Set-up Time	CL2 → CL1	500	-	ns	CL1,CL2
TLS	Clock Set-up Time	CL1 → CL2	500	-	ns	CL1,CL2
TR/TF	Clock Rise/Fall Time	-	-	200	ns	CL1,CL2
TSU	Data Set-up Time	-	300	-	ns	DL1,DL2,DR1,DR2
TDH	Data Hold Time	-	300	-	ns	DL1,DL2,DR1,DR2
TD	Data Delay Time	CL = 15 PF	-	500	ns	DL1,DL2,DR1,DR2



10. Power Supply

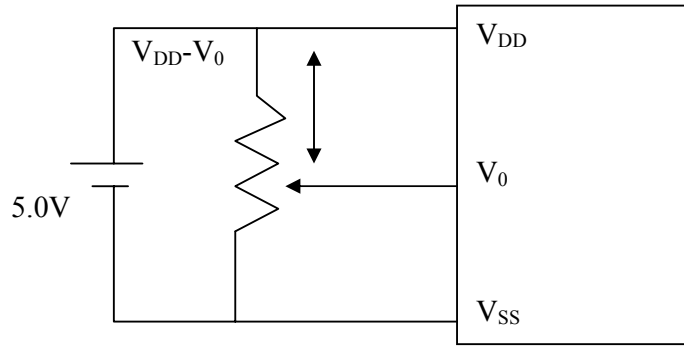

Where  $V_{DD}-V_0 = \text{LCD Driving voltage}$

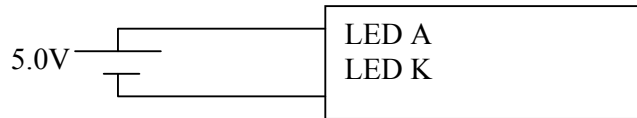

For backlight version only

11. Block Diagram

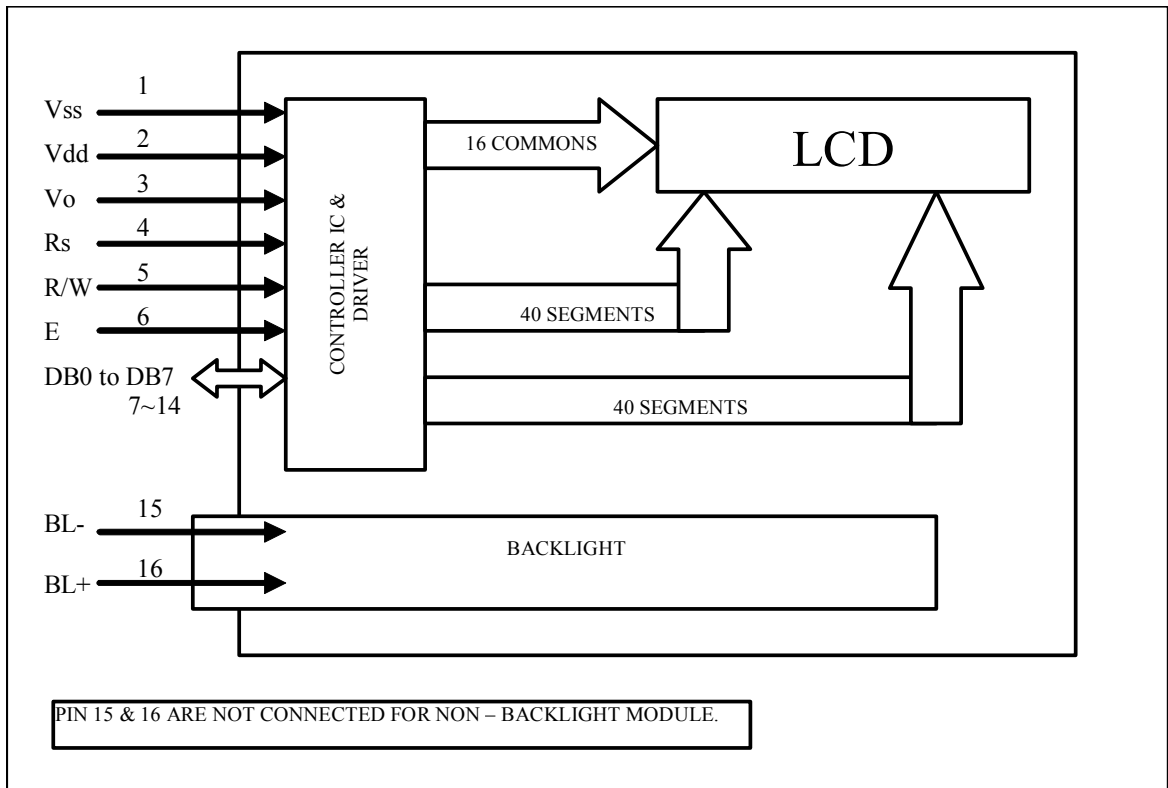



12. Instructions

Instruction	Instruction Code										Description	Description Time (270KHZ)
	RS	RW	DB 7	DB 6	DB 5	DB 4	DB 3	DB 2	DB 1	DB 0		
Clear Display	0	0	0	0	0	0	0	0	0	1	Write "20H" to DDRAM. and set DDRAM address to "00H" from AC	1.52 ms
Return Home	0	0	0	0	0	0	0	0	0	1 x	Set DDRAM address to "00H" from AC and return cursor to its original position if shifted. The contents of DDRAM are not changed.	1.52 ms
Entry Mode Set	0	0	0	0	0	0	0	0	1	I/D S	Sets cursor move direction and specifies display shift. These operations are performed during data write and read.	37 us
Display ON/OFF	0	0	0	0	0	0	0	1	D	C B	D=1: entire display on C=1: cursor on B=1: cursor position on	37 us
Cursor or Display Shift	0	0	0	0	0	1	S/C	R/L	x	x	Set cursor moving and display shift control bit, and the direction, without changing DDRAM data.	37 us
Function Set	0	0	0	0	1	DL	N	F	x	x	DL: interface data is 8/4 bits NL: number of line is 2/1 F: font size is 5x11/5x8	37 us
Set CGRAM address	0	0	0	1	AC 5	AC 4	AC 3	AC 2	AC 1	AC 0	Set CGRAM address in address counter	37 us
Set DDRAM address	0	0	1	AC 6	AC 5	AC 4	AC 3	AC 2	AC 1	AC 0	Set DDRAM address in address counter	37 us
Read Busy flag and address	0	1	BF	AC 6	AC 5	AC 4	AC 3	AC 2	AC 1	AC 0	Whether during internal operation or not can be known by reading BF. The contents of address counter can also be read.	0 us
Write data to RAM	1	0	D7	D6	D5	D4	D3	D2	D1	D0	Write data into internal RAM (DDRAM/CGRAM)	37 us
Read data from RAM	1	1	D7	D6	D5	D4	D3	D2	D1	D0	Read data from internal RAM (DDRAM/CGRAM)	37 us



8 bit operation example.

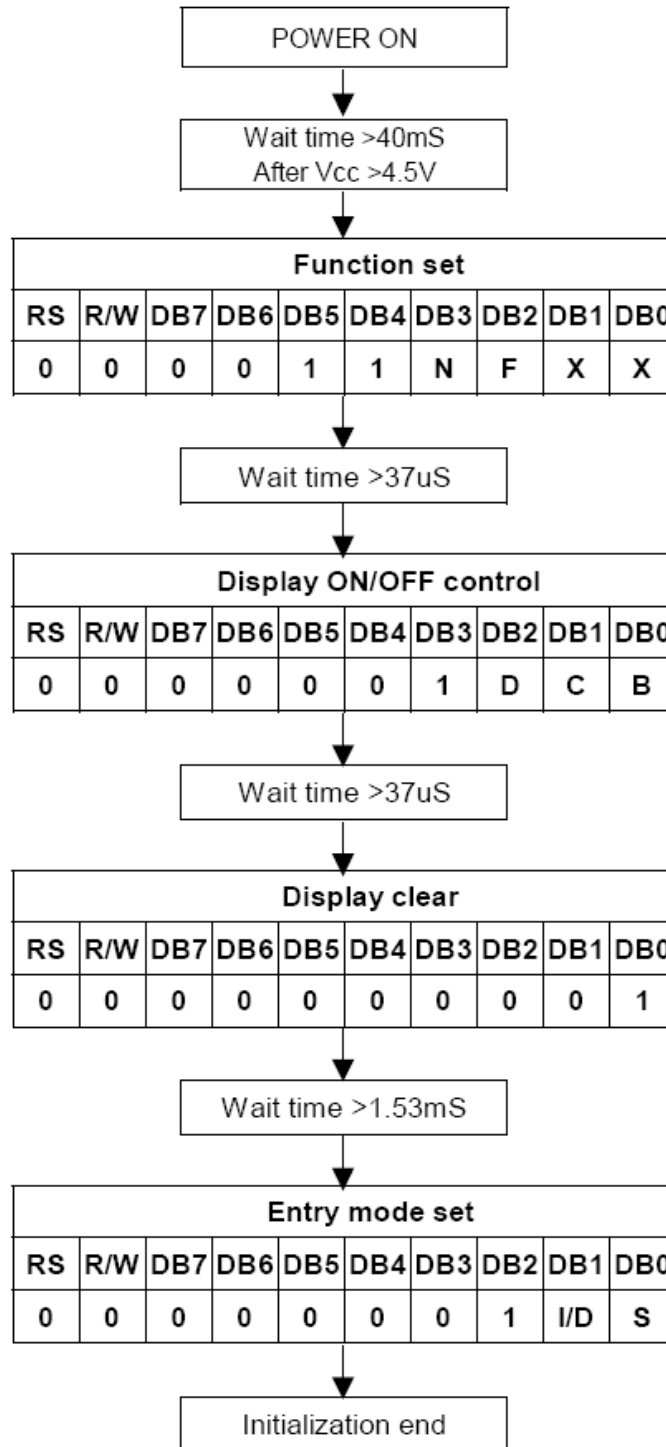



Relationship between character code (DDRAM) and character pattern (CGRAM)

Character Code (DDRAM Data)								CGRAM Address						Character Patterns (CGRAM Data)							
b7	b6	b5	b4	b3	b3	b1	b0	b5	b4	b3	b2	b1	b0	b7	b6	b5	b4	b3	b2	b1	b0
0	0	0	0	-	0	0	0	0	0	0	0	0	0	-	-	-	1	1	1	1	1
					0	0	0				0	0	0				0	0	0		
					0	0	0				0	0	0				0	0	0		
					0	0	0				0	0	0				0	0	0		
					0	0	0				0	0	0				0	0	0		
					0	0	0				0	0	0				0	0	0		
					0	0	0				0	0	0				0	0	0		
					0	0	0				0	0	0				0	0	0		
					0	0	0				0	0	0				0	0	0	0	0
0	0	0	0	-	0	0	1	0	0	0	0	0	0	-	-	-	1	1	1	1	0
					0	0	1				0	0	1				0	0	1		
					0	0	1				0	1	0				0	1	0	1	
					0	0	1				0	1	1				0	1	1	0	
					0	0	1				0	1	0				0	1	0	0	
					0	0	1				0	1	1				0	1	0	1	
					0	0	1				0	1	0				0	1	0	0	
					0	0	1				0	1	1				0	1	0	0	1
					0	0	1				0	1	1				1	1	1	0	0





Character Generator ROM (ST7066U-0A-B)

b7-b4 b3-b0	0000	0001	0010	0011	0100	0101	0110	0111	1000	1001	1010	1011	1100	1101	1110	1111
0000	CG RAM (1)			0	1	2	3	4	5	6	7	8	9	A	B	C
0001	(2)	!	@	#	\$	%	&	'	(	)	*	+	=	>	?/	□
0010	(3)	"	#	\$	%	&	'	(	)	*	+	=	>	?/	□	■
0011	(4)	#	\$	%	&	'	(	)	*	+	=	>	?/	□	■	■
0100	(5)	\$	%	&	'	(	)	*	+	=	>	?/	□	■	■	■
0101	(6)	%	&	'	(	)	*	+	=	>	?/	□	■	■	■	■
0110	(7)	&	'	(	)	*	+	=	>	?/	□	■	■	■	■	■
0111	(8)	'	(	)	*	+	=	>	?/	□	■	■	■	■	■	■
1000	(1)	(	)	*	+	=	>	?/	□	■	■	■	■	■	■	■
1001	(2)	)	*	+	=	>	?/	□	■	■	■	■	■	■	■	■
1010	(3)	*	+	=	>	?/	□	■	■	■	■	■	■	■	■	■
1011	(4)	+	=	>	?/	□	■	■	■	■	■	■	■	■	■	■
1100	(5)	=	>	?/	□	■	■	■	■	■	■	■	■	■	■	■
1101	(6)	>	?/	□	■	■	■	■	■	■	■	■	■	■	■	■
1110	(7)	?/	□	■	■	■	■	■	■	■	■	■	■	■	■	■
1111	(8)	□	■	■	■	■	■	■	■	■	■	■	■	■	■	■



13.0 Quality Assurance

13.1 ZONE DEFINITION

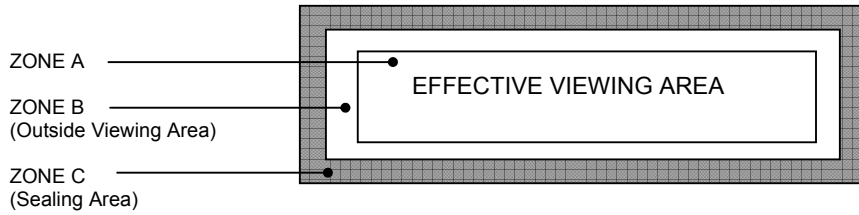

13.1.1 Black Spot, White Spot and Foreign Material

Defect Category	Defect Description	Criterion			Drawing Specification		
		Zone / Dimension	Acceptable No.				
Black Spot, White Spot and Foreign Material	Black Spot, White Spot and Foreign Material	$D \leq 0.10\text{mm}$	NC	NC	NC	<p><math>D = (A + B)/2</math></p>	
		$0.10 < D \leq 0.20\text{mm}$	3	3	NC		
		$0.20 < D \leq 0.30\text{mm}$	1	2	NC		
		$D > 0.30\text{ mm}$	0	0	NC		
		NC: No count					
		D: Mean Diameter of Defect					

13.1.2 Line Shape and Scratches

Defect Category	Defect Description	Criterion			Drawing Specification		
		Zone /Dimension	Acceptable No.				
Line shape and scratches	Line shape and scratches	X	Y	A	B	C	
		-	<0.01mm	NC	NC	NC	
		< 2 mm	< 0.02mm	1	1	NC	
		<1 mm	< 0.0 2mm	1	2	NC	

13.1.3 Pin Hole

Defect Category	Defect Description	Criterion	Drawing Specification
Pin Hole	Pin hole / void at light up segment	$D \leq 0.20\text{mm}$ within 1 part/segment	<p><math>D = (A + B)/2</math></p>



13.1.4 Polarizer Bubble/Foreign Material

Defect Category	Defect Description	Criterion			Drawing Specification	
	Polarizer bubble / Foreign material	Zone / Dimension	Acceptable No.			<p><math>D = (A + B)/2</math></p>
		$D \leq 0.15\text{mm}$	NC	NC	NC	
		$0.15 < D \leq 0.30\text{mm}$	3	5	NC	
		$0.30 < D \leq 0.50\text{mm}$	2	3	NC	
		$0.50 < D \leq 1.0\text{mm}$	0	1	NC	
		NC: No count				
		D: Mean Diameter of Defect				
	Accept - if air bubble at the seal area does not propagate into effective viewing area					

Note: Total defects shall not exceed five



## 14. Precaution for using LCM

### 1. Liquid Crystal Display (LCD)

LCD is made up of glass, organic sealant, organic fluid and polymer based polarizers. The following precautions should be taken when handling.

- b) Keep the temperature within the range of use and storage. Excessive temperature and humidity could cause polarization degradation, polarizer peel off or bubble.
- c) Do not contact the exposed polarizer with anything harder than HB pencil lead. To clean dust off the display surface, wipe gently with cotton, chamois or other soft material soaked in petroleum benzin.
- d) Wipe off saliva or water drops immediately. Contact with water over a long period of time may cause polarizer deformation or colour fading, while an active LCD with water condensation on its surface will cause corrosion of ITO electrodes.
- e) Glass can be easily chipped or cracked from rough handling, especially at corners and edges.
- f) Do not drive LCD with DC voltage.

### 2. Liquid Crystal Display Modules.

#### 2.1 Mechanical Considerations

LCM are assembled and adjusted with a high degree of precision. Avoid excessive shocks and do not make any alterations or modification. The following should be noted.

- a) Do not tamper in any way with the tabs on the metal frame.
- b) Do not modify the PCB by drilling extra holes, changing its outline, moving its component or modifying its pattern.
- c) Do not touch the elastomer connector, especially insert a backlight panel (for example, EL)
- d) When mounting a LCM make sure that the PCB is not under any stress such as bending or twisting. Elastomer contacts are very delicate and missing pixels could result from slight dislocation of any of the elements.

- a) Avoid pressing on the metal bezel, otherwise the elastomer connector could be deformed and lose contact, resulting in missing pixels.

#### 2.2 Static Electricity

LCM contains CMOS LSI's and the same precaution for such devices should apply, namely

- a) The operator should be grounded whenever he/she comes into contact with the module. Never touch any of the conductive parts such as the LSI pads, the copper leads on the PCB and the interface terminals with any parts of the human body.
- b) The modules should be kept in antistatic bags or other containers to static for storage.
- c) Only properly grounded soldering irons should be used.
- d) If an electric screwdriver is used, it should be well grounded and shielded from commutator spark.
- e) The normal static prevention measures should be observed for work clothes and working benches, the latter conductive (rubber) mat is recommended.
- f) Since dry air is inductive to statics, a relative humidity of 50-60% is recommended.

#### 2.3 Soldering

- a) Solder only to the I/O terminals.
- b) Use only soldering irons with proper grounding and no leakage.
- c) Soldering temperature: 280 °C
- d) Soldering time: 3 to 4 sec
- e) Use eutectic solder with resin flux fill.
- f) If flux is used, the LCD surface should be covered to avoid flux spatters. Flux residue should be removed afterwards.



#### 2.4 Operation

- a) The contrast can be adjusted by varying the LCD driving voltage  $V_0$
- b) Driving voltage should be kept within specified range, excess voltage shortens display life.
- c) Response time increases with decrease in temperature.
- d) Display may turn black or dark blue at temperature above its operational range, this is (however not pressing on the viewing area) may cause the segments to appear “fractured”.
- e) Mechanical disturbance during operation (such as pressing on the viewing area) may cause the segments to appear “fractured”.

#### 2.5 Storage

If any fluid leaks out of the damaged glass cell, wash off any human part that comes into contact with soap and water. Never swallow the fluid. The toxicity is extremely low but caution should be exercised at all the time.

#### 2.6 Limited Warranty

Unless otherwise agreed between Crystal Clear Technology and customer, Crystal Clear Technology will replace or repair any of its LCD and LCM which is found to be defective electrically and visually when inspected in accordance with Crystal Clear Technology acceptance standards, for a period of one year from date of shipment. Confirmation of such date shall be based on freight documents. The warranty liability of Crystal Clear Technology is limited to repair and/or replacement on the terms set forth above. Crystal Clear Technology will not be responsible for any subsequent or consequential events.



**CRYSTAL CLEAR TECHNOLOGY SDN. BHD.**

**Spec. No: C216x05xxW00 REV1.0**

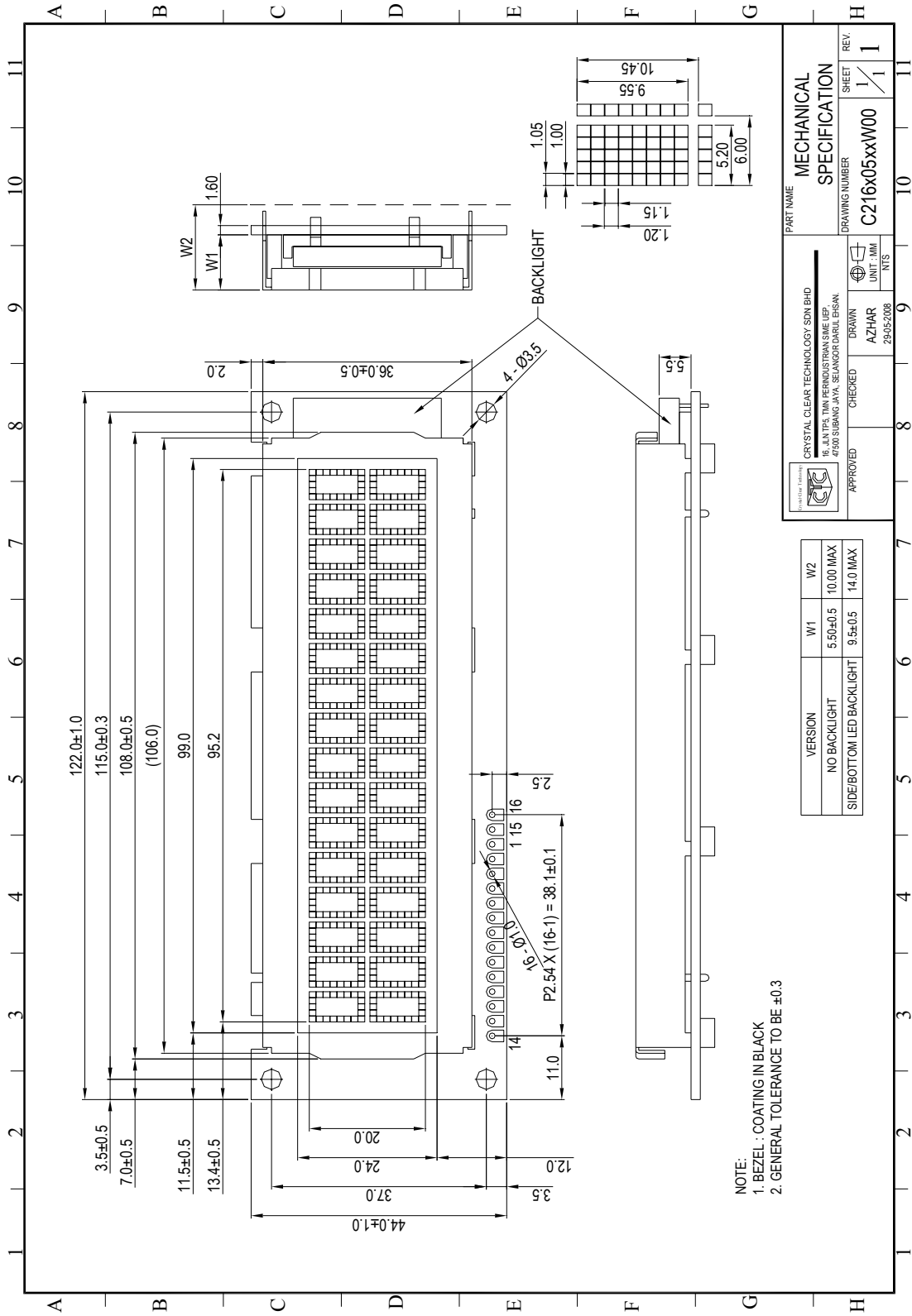



**Crystal Clear Technology**  
16 Jalan TP5—Taman Perindustrian Sime UEP  
47600 Subang Jaya—Selangor DE  
Malaysia