



Up counters/Down - 48 x 48 - CTR48 Multicoloured LCD display (green-red) Part number 87621211



- Counter, Tachometer, Chronometer, Multi-totalizer, Batch counter, Preselection totalizer
- Maximum input frequency 40 k Hz
- Simple parameter setting, configuration using text menus
- Easy modification of presets
- Scaling factor
- 5 A changeover relay and solid state output
- Removable connectors
- Backlit LCD display (orange) : 2 lines, 6 digits or multicoloured display (green-red)
- IP 65 sealed panel
- Option of locking the keypad, completely or partially (preset, programming)
- Accessories for 72 x 72 or 55 x 55 cut-out, DIN rail adaptor

	Type	Functions	Preset	Voltages	Output
87621111	Orange backlit LCD display	Counter, Tachometer, Chronometer, Preselection multi-totalizer	1	10 →30 VDC	1 changeover relay, 1 solid state
87621112	Orange backlit LCD display	Counter, Tachometer, Chronometer, Preselection multi-totalizer	1	24 VAC	1 changeover relay, 1 solid state
87621115	Orange backlit LCD display	Counter, Tachometer, Chronometer, Preselection multi-totalizer	1	90 →260 VAC	1 changeover relay, 1 solid state
87621211	Orange backlit LCD display	Counter, Tachometer, Chronometer, Multi-totalizer, Batch counter, Preselection totalizer	2	10 →30 VDC	1 changeover relay, 1 NO relay, 2 solid state
87621212	Orange backlit LCD display	Counter, Tachometer, Chronometer, Multi-totalizer, Batch counter, Preselection totalizer	2	24 VAC	1 changeover relay, 1 NO relay, 2 solid state
87621215	Orange backlit LCD display	Counter, Tachometer, Chronometer, Multi-totalizer, Batch counter, Preselection totalizer	2	90 →260 VAC	1 changeover relay, 1 NO relay, 2 solid state
87621211	Multicoloured LCD display (green-red)	Counter, Tachometer, Chronometer, Preselection multi-totalizer	1	10 →30 VDC	1 changeover relay, 1 solid state
87621212	Multicoloured LCD display (green-red)	Counter, Tachometer, Chronometer, Preselection multi-totalizer	1	24 VAC	1 changeover relay, 1 solid state
87621215	Multicoloured LCD display (green-red)	Counter, Tachometer, Chronometer, Preselection multi-totalizer	1	90 →260 VAC	1 changeover relay, 1 solid state
87621221	Multicoloured LCD display (green-red)	Counter, Tachometer, Chronometer, Multi-totalizer, Batch counter, Preselection totalizer	2	10 →30 VDC	1 changeover relay, 1 NO relay, 2 solid state
87621222	Multicoloured LCD display (green-red)	Counter, Tachometer, Chronometer, Multi-totalizer, Batch counter, Preselection totalizer	2	24 VAC	1 changeover relay, 1 NO relay, 2 solid state
87621225	Multicoloured LCD display (green-red)	Counter, Tachometer, Chronometer, Multi-totalizer, Batch counter, Preselection totalizer	2	90 →260 VAC	1 changeover relay, 1 NO relay, 2 solid state

Physical details and protection

Supply	10 →30 VDC / 24 V AC / 90 →260 VAC
Relative humidity (no condensation)	EN 60068-2-30 40/93 % RLF
Altitude	0 < 2000 m
Certifications	UL - cULus (pending) - CE
Vibration resistance in 3 axes	10-55 Hz/1 min/XYZ EN 60068-2-6 : 30 min. in each direction
Connection by screw terminals	Removable
Protection	Conforming to standard EN 60529 IP65 for panel/IP20 for connections
Front panel watertight seal	■
Temperature limits use (°C)	-20 →+65
Temperature limits stored (°C)	-25 →+75
Weight (g)	150 DC version 250 AC version

General characteristics

Reset to zero or to preset	On panel : if not locked during programming Electrical : automatic, voltage or solid state (NPN or PNP depending on programming)
Minimum pulse time	Impulse counter : < 15 ms Chronometer : 500 µs
Option to protect against reset from front panel	■
Scale factor (each input pulse is multiplied by this figure)	00,0001 →99,9999
Scaling factor (each input impulse is divided by this value)	01,0000 →99,9999
Decimal point selectable for ease of reading	0 0,0 0,00 0,000 0,0000 0,00000
Sensor supply version AC	24 VDC -20/+15 % 50 mA
Programming and current value backed up via EEPROM memory	■ Service life 10 years

Operating characteristics

Functions	Preselection counter, Tachometer, Chronometer, Multi-totalizer, Batch counters, Totalizer
-----------	---

Number of presets	1 or 2
Display	LCD with orange backlighting/Multicoloured LCD (green-red)
Height digits (mm)	LCD 9
Display details	- 999 999 → 999 999

Inputs specifications

Inputs	2 counter inputs 1 reset input, 1 gate input
Input modes	Dir : Directional AS : up/dn AA : up/up PP : phase PP2 : phase 2 PP4 : phase 4
Input type	Voltage or solid state
High level	8 VDC→30 VDC
Low level	0 →2 VDC

Solid state output characteristics

Maximum current	30 mA
Max. voltage	10 →30 VDC for the DC version 24 VDC -20/+15 %

Relay output characteristics

Changeover relay	▪
NO contact	Depending on version
Maximum current	5 A
Minimum current	10 mA
Maximum voltage	30 VDC / 250 VAC
Min. voltage	5 VAC/DC
Response time	< 13 ms
Mechanical life (operations)	20 x 10 ⁶
Number of operations to 5 A	5 x 10 ⁴
Output modes : maintained or pulsed	0.01 →99.99 s

Description

Adaptor for 72 x 72 mm cut-out
Adaptor for 55 x 55 mm cut-out
DIN rail adaptor

Code

26546842
26546846
26546841

Dimension Diagram :

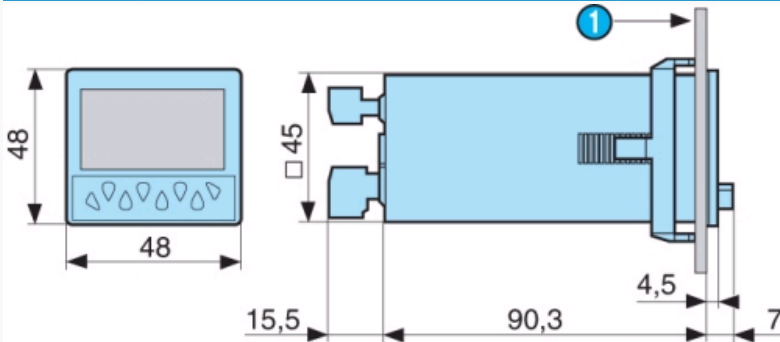

N°

1

Legend

10.5 max.

Dimension Diagram : 26546842 - Adaptor for 72 x 72 mm cut-out

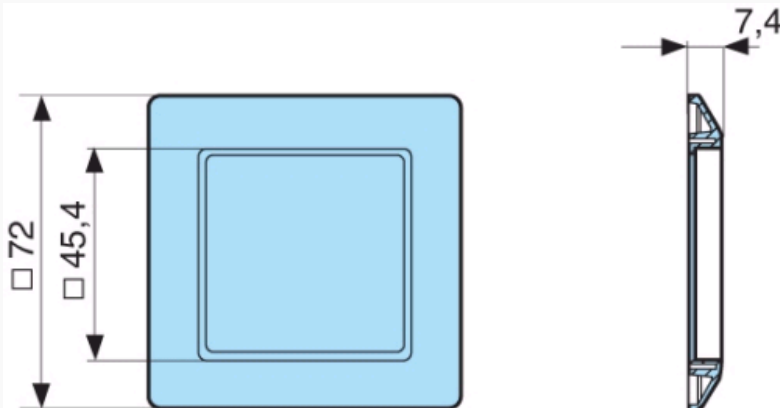

Dimension Diagram : 26546846 - Adaptor for 55 x 55 mm cut-out

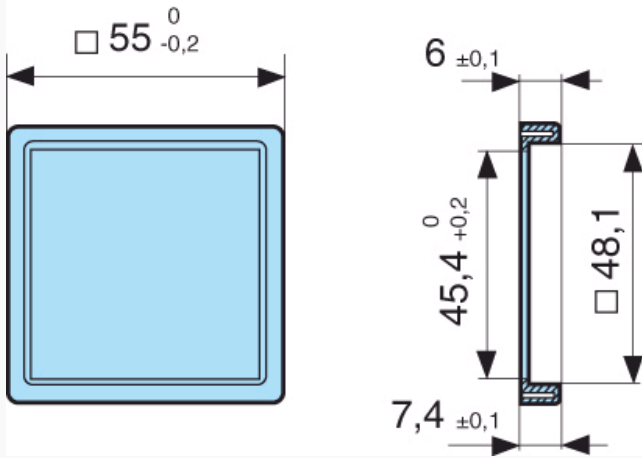

Dimension Diagram : Panel cut-out

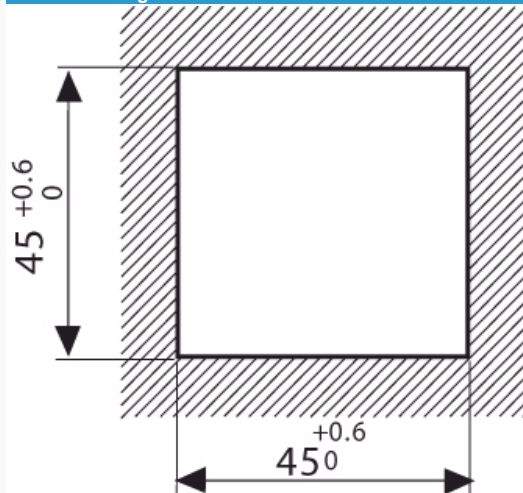

Dimension Diagram : 26546841 - DIN rail adaptor

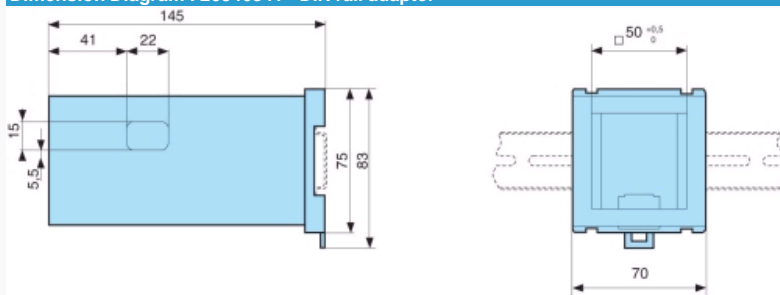

: Display and buttons

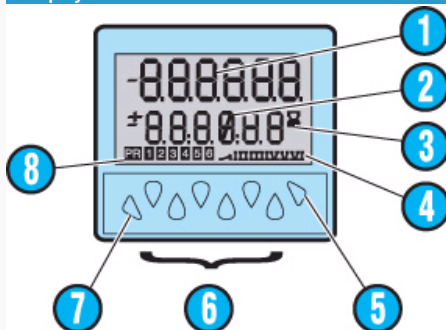

N°	Legend
1	Current value
2	Selected value
3	Chronometer display
4	Active output indication
8	Shows which value is displayed
5	Prog/mode button
6	Preset control buttons
7	Button required for programming parameters

Curves : Counter : dir

dir

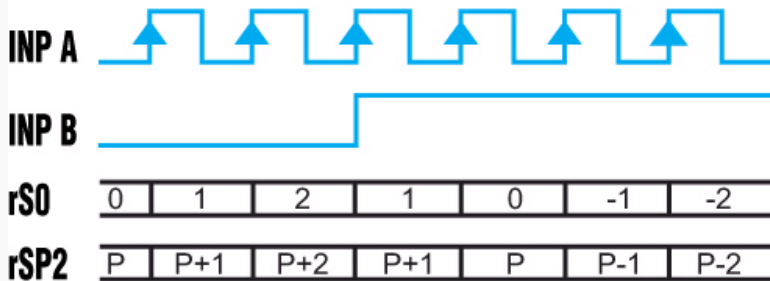

Curves : Counter : AS

AS

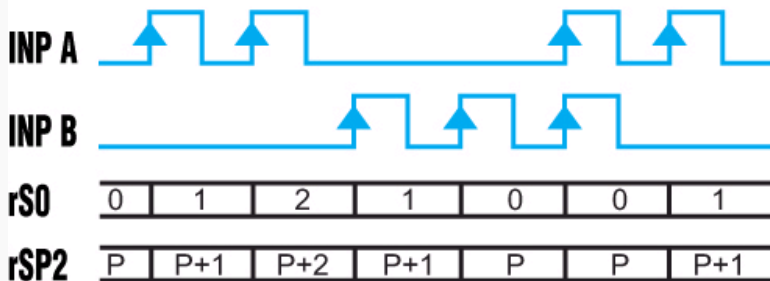

Curves : Counter : AA

AA

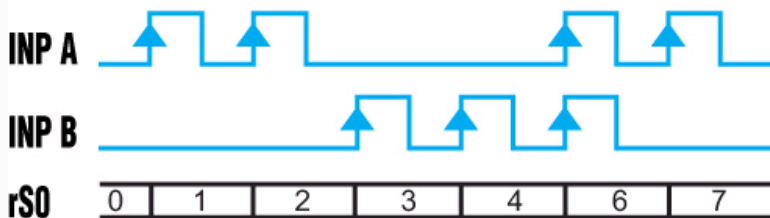

Curves : Counter : PP

PP

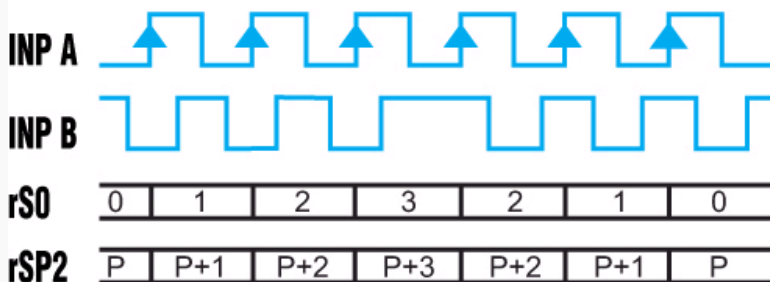

Curves : Counter : PP2

PP2

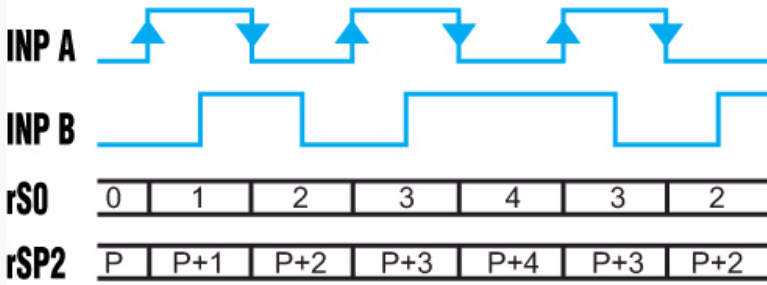

Curves : Counter : PP4

PP4

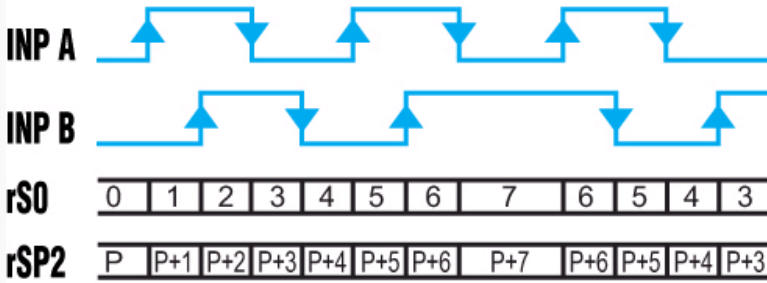

Curves : Chronometer : Start tcCb

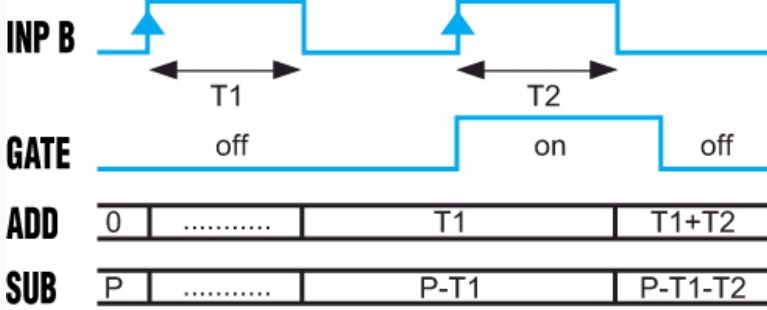

Curves : Chronometer : Start tcCbb

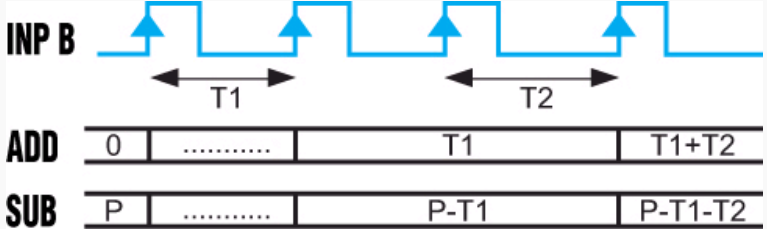

Curves : Chronometer : Start tcCAb

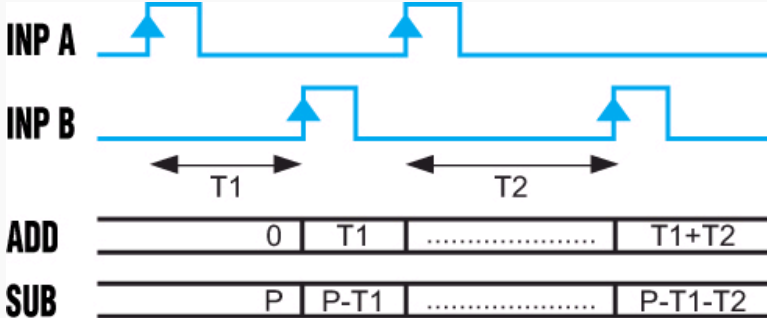

Curves : Chronometer : Start tcSb

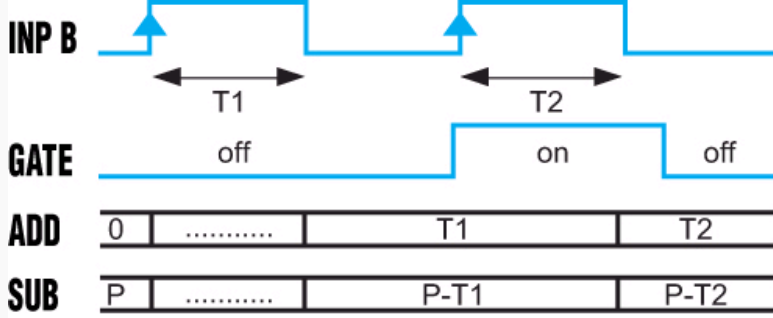

Curves : Chronometer : Start tcSbb

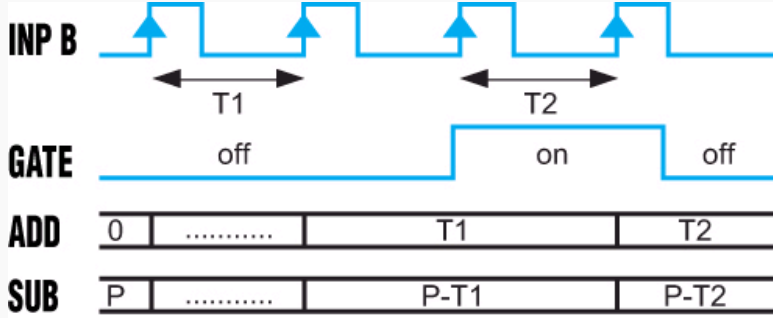

Curves : Chronometer : Start tcSAb

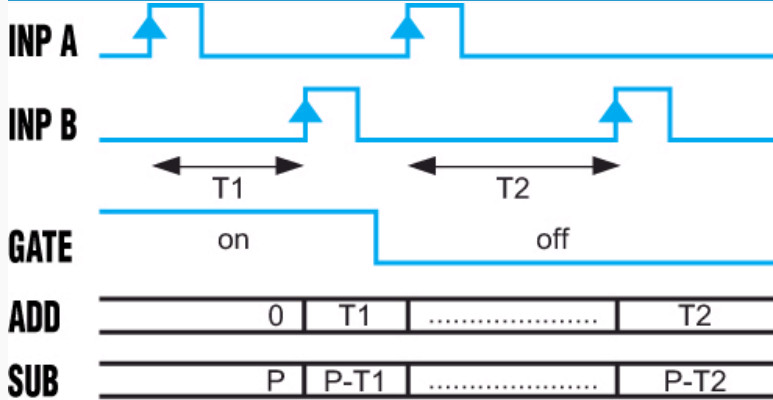

Curves : Chronometer : Start tcAuto

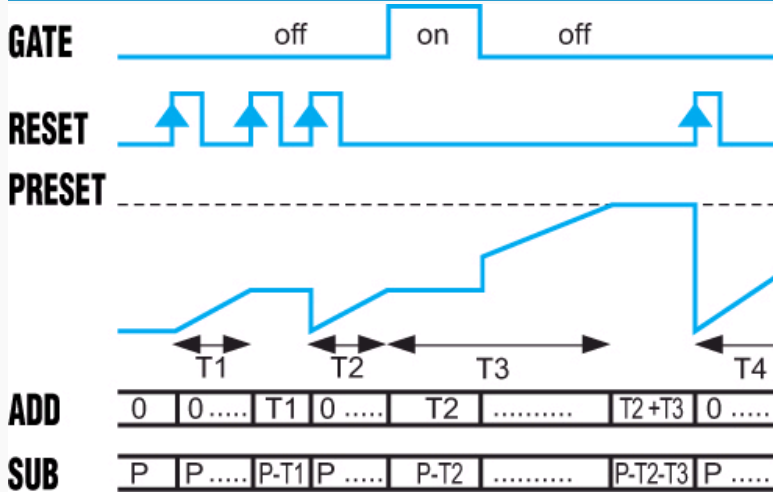

Curves : Tachometer : Start tA.A

INP A

0	F _{A0}	F _{A1}	F _{A2}	0	x
---	-----------------	-----------------	-----------------	---	---

Display

0	0	F _{A0}	F _{A1}	F _{A2}	0
---	---	-----------------	-----------------	-----------------	---

Curves : Tachometer : Start tA.AS

INP A

0	F _{A0}	F _{A1}	F _{A2}	0	x
---	-----------------	-----------------	-----------------	---	---

INP B

0	0	F _{B0}	F _{B1}	F _{B2}	x
---	---	-----------------	-----------------	-----------------	---

Display

0	0	F _{A0}	F _{A0} - F _{B0}	F _{A1} - F _{B1}	- F _{B2}
---	---	-----------------	-----------------------------------	-----------------------------------	-------------------

Curves : Tachometer : Start tA.AA

INP A

0	F _{A0}	F _{A1}	F _{A2}	0	x
---	-----------------	-----------------	-----------------	---	---

INP B

0	0	F _{B0}	F _{B1}	F _{B2}	x
---	---	-----------------	-----------------	-----------------	---

Display

0	0	F _{A0}	F _{A0} + F _{B0}	F _{A1} + F _{B1}	F _{B2}
---	---	-----------------	-----------------------------------	-----------------------------------	-----------------

Curves : Tachometer : Start tA.PP

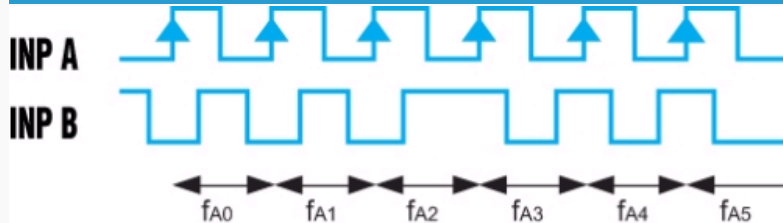

Display

0	0	F _{A0}	F _{A1}	F _{A2}	-F _{A3}	-F _{A4}
---	---	-----------------	-----------------	-----------------	------------------	------------------

Curves : Output operation : OutoP rS0

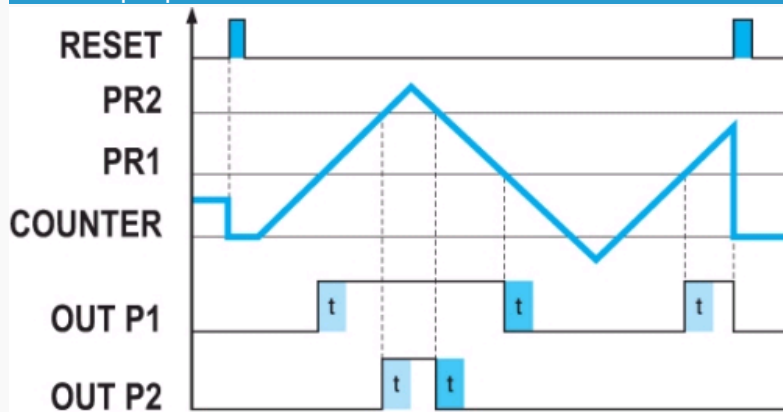

Curves : Output operation : OutoP rSA0

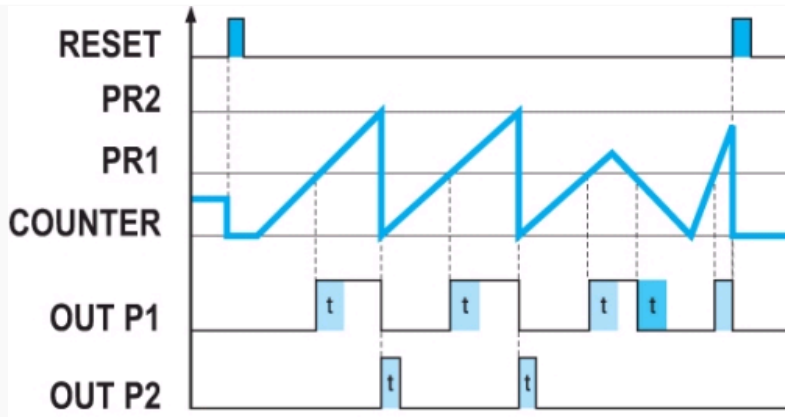

Curves : Output operation : OutoP bCrSA0

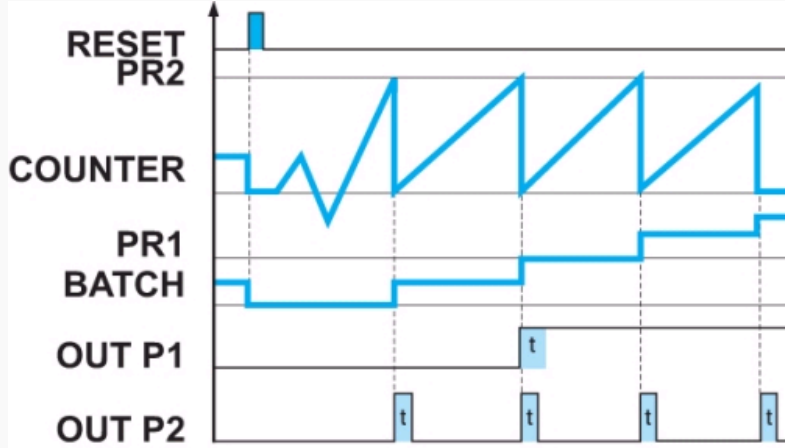

Curves : Output operation : OutoP tCrSA0

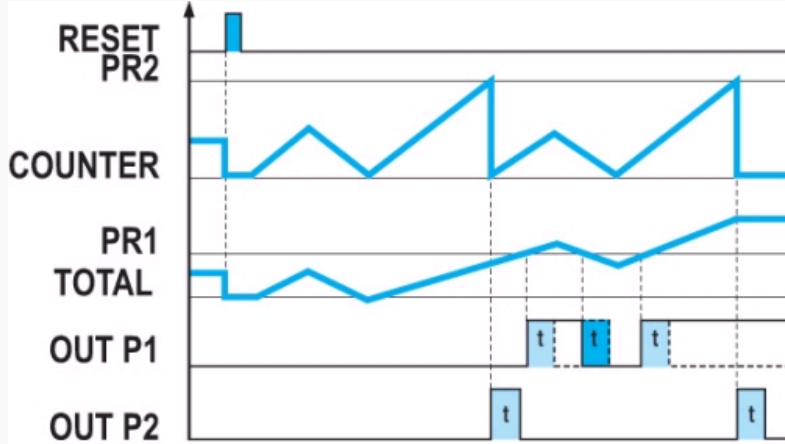

Curves : Output operation : OutoP rSP2

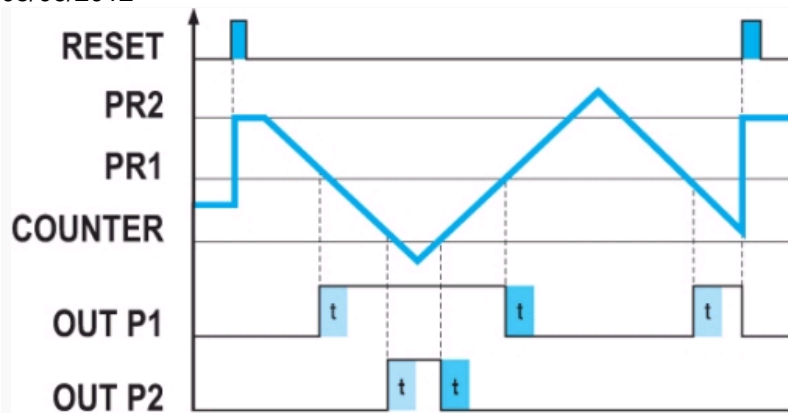

Curves : Output operation : OutoP rSAP2

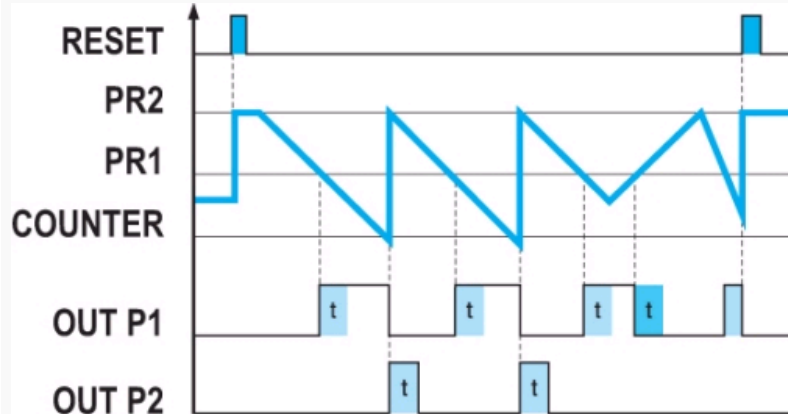

Curves : Output operation : OutoPbCrSA2

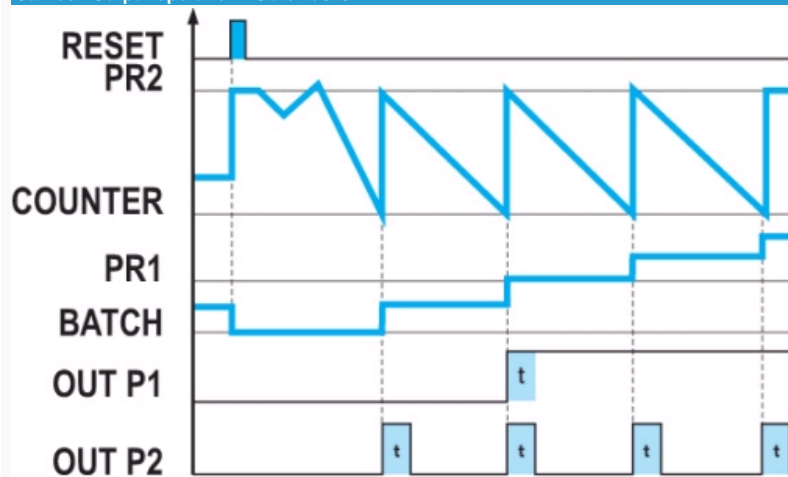

Curves : Output operation : OutoP tCrSA2

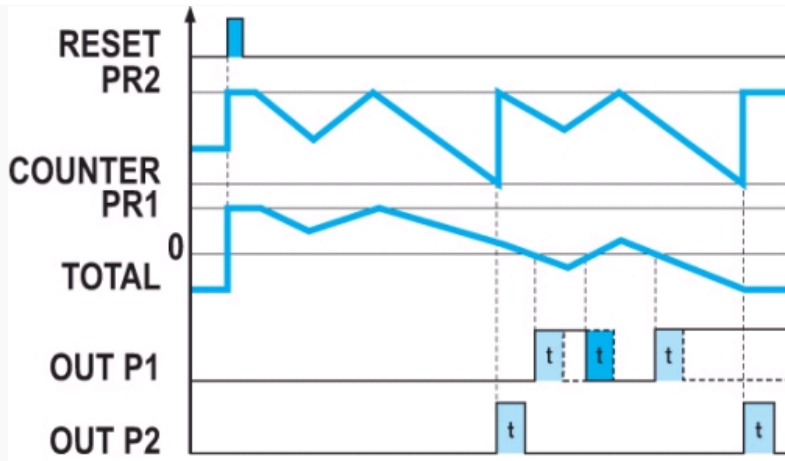

Curves : Output operation : OutoP bCrS0

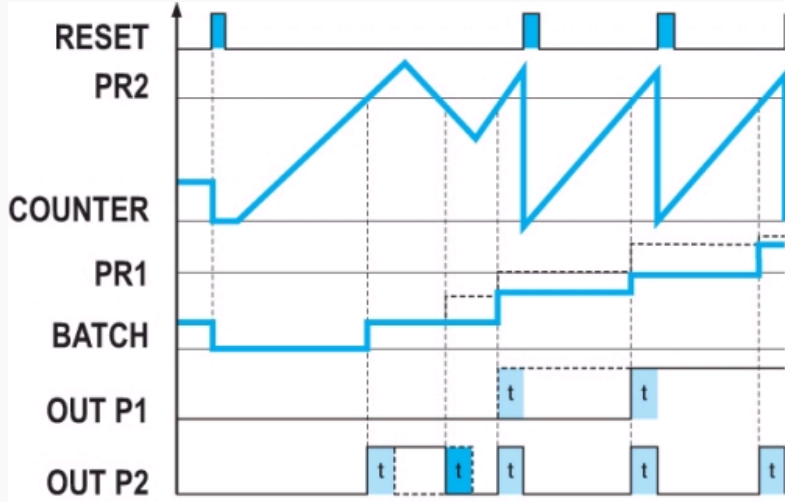

Curves : Output operation : OutoP tCrS0

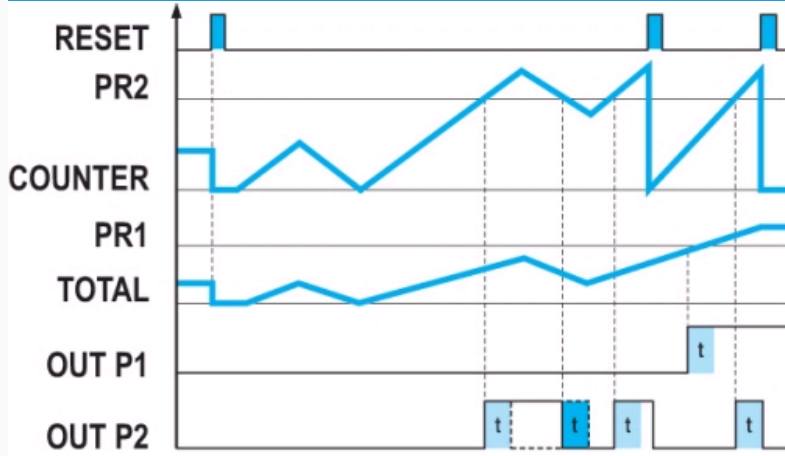

Curves : Output operation : OutoP MurS0 (AA)

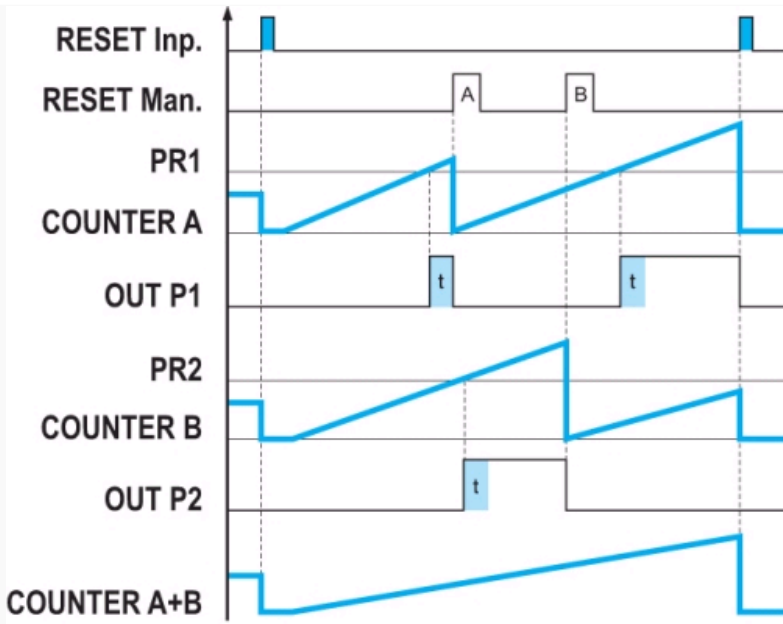

Curves : Output operation : OutoP bCrSP2

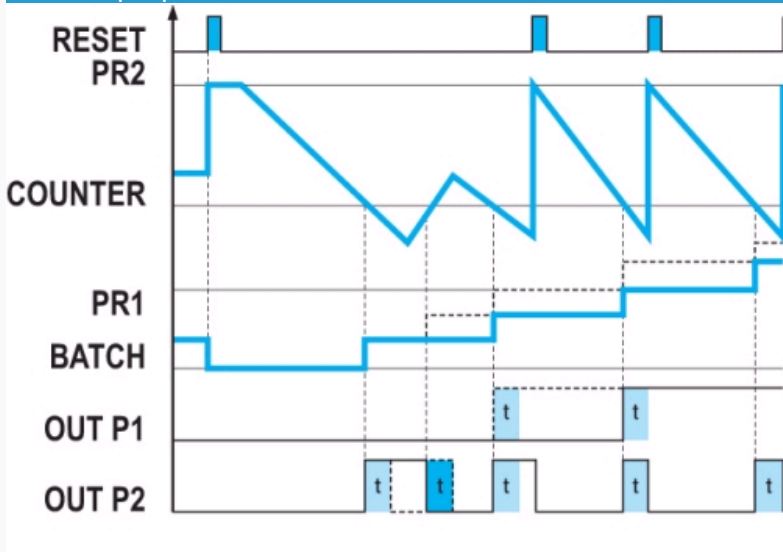

Curves : Output operation : OutoP tCrSP2

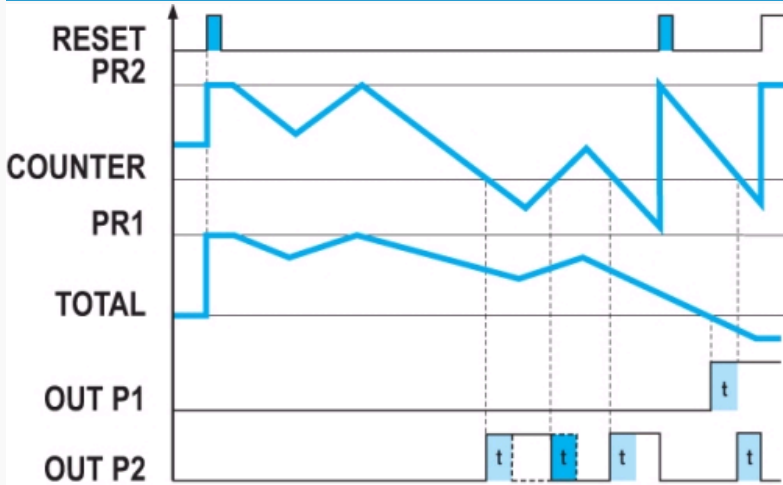

Curves : Output operation : OutoP MurS0 (AS)

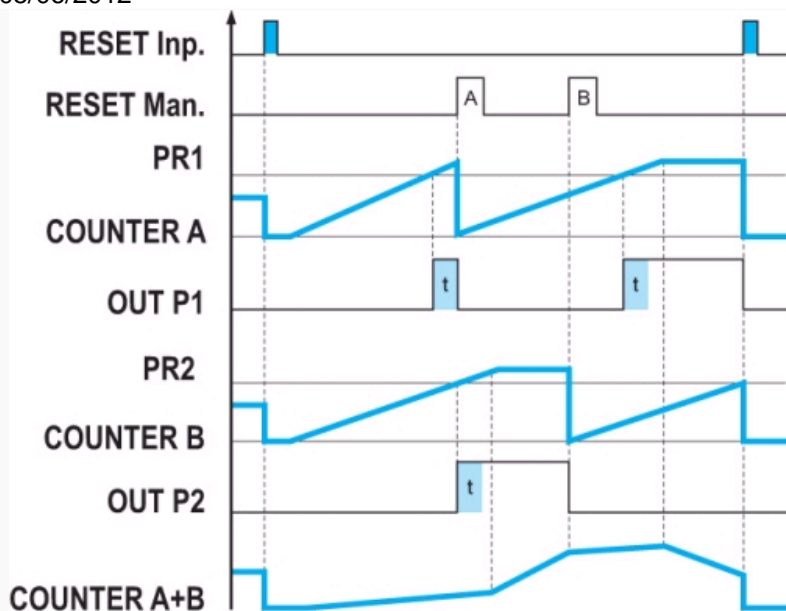

: 87621111 / 211

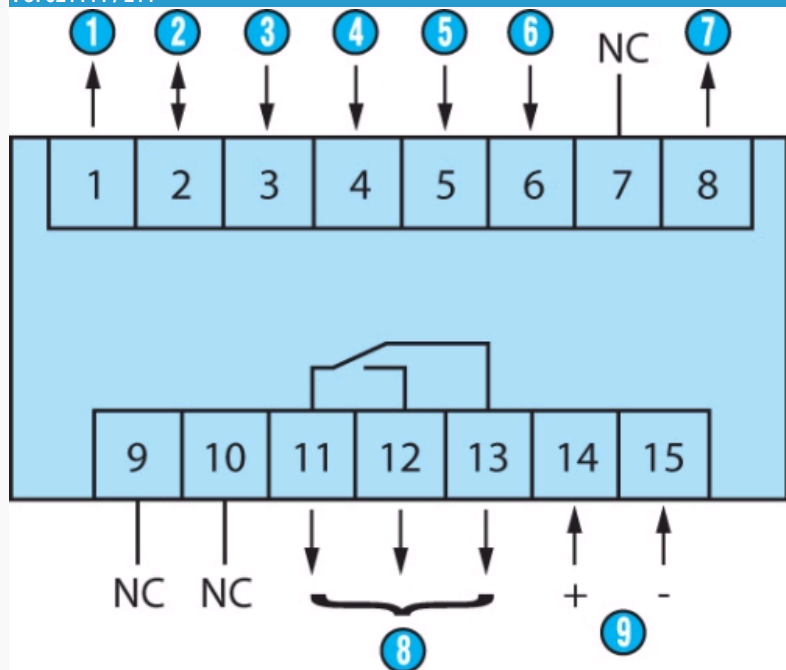

N°	Legend
1	Sensor voltage supply (* UB interconnected)
2	GND (0 VDC)
3	INP A (signal A input)
4	INP B (signal B input)
5	Reset (Reset input)
6	Gate input
7	Output 1 - 10-30 VDC/30 mA
8	11-12-13 : Output 1
9	14-15 : Supply

: 87621112 / 212

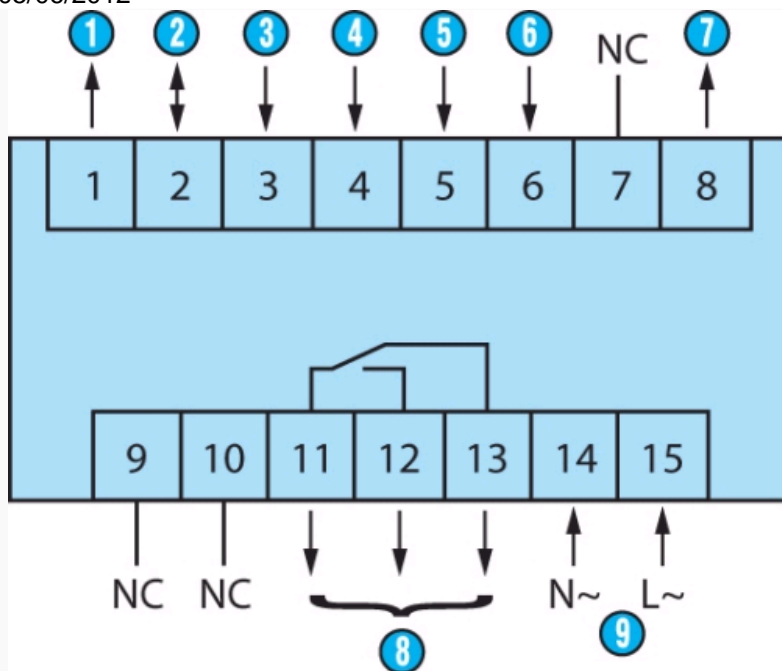

N°	Legend
1	Sensor voltage supply
2	GND (0 VDC)
3	INP A (signal A input)
4	INP B (signal B input)
5	Reset (Reset input)
6	Gate input
7	Output 1 - 24 VDC/30 mA
8	11-12-13 : Output 1
9	14-15 : Supply

: 87621115 / 215

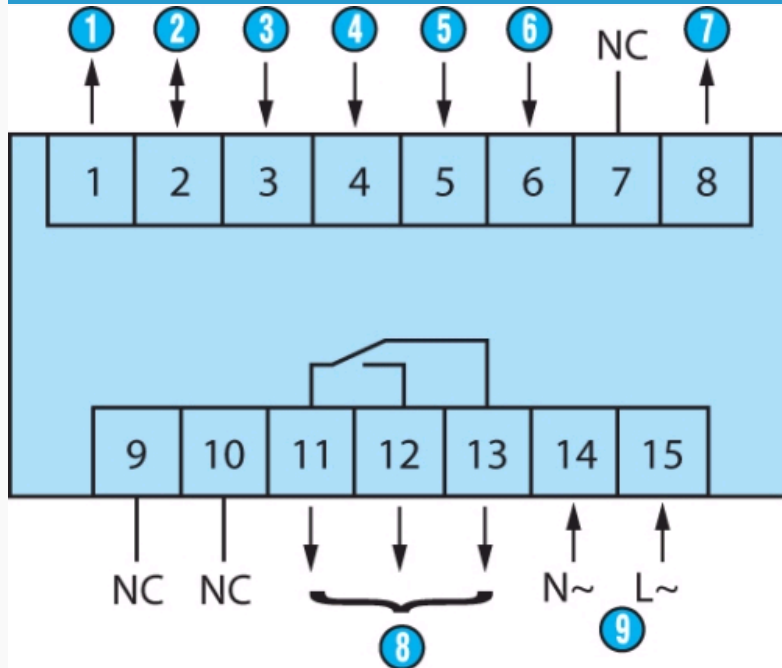

N°	Legend
1	Sensor voltage supply
2	GND (0 VDC)
3	INP A (signal A input)
4	INP B (signal B input)
5	Reset (Reset input)
6	Gate input
7	Output 1 - 24 VDC/30 mA

: 87621121 / 221

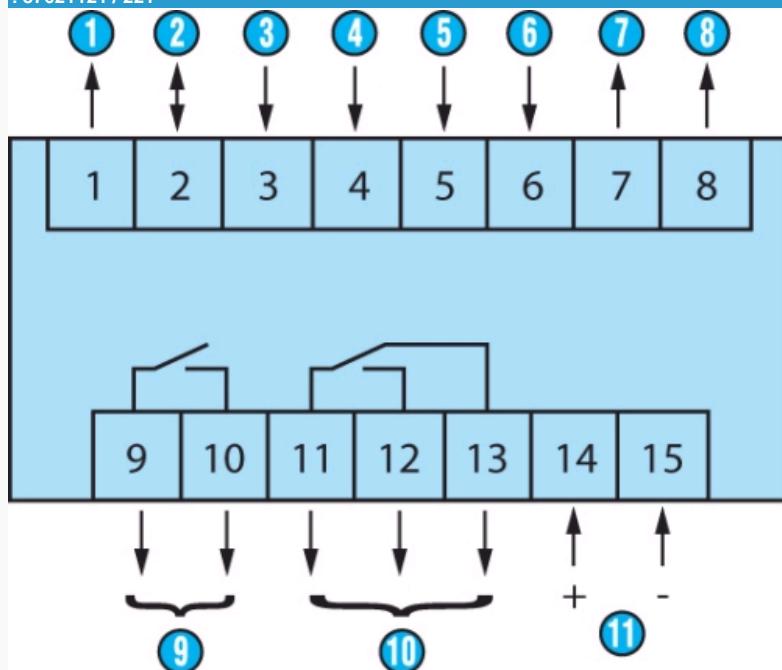

N° Legend

- 1 Sensor voltage supply (* UB interconnected)
- 2 GND (0 VDC)
- 3 INP A (signal A input)
- 4 INP B (signal B input)
- 5 Reset (Reset input)
- 6 Gate input
- 7 Output 1 : 10-30 VDC/30 mA
- 8 Output 2 : 10-30 VDC/30 mA
- 9 9-10 : Output 1
- 10 11-12-13 : Output 2
- 11 14-15 : Supply

: 87621122 / 222

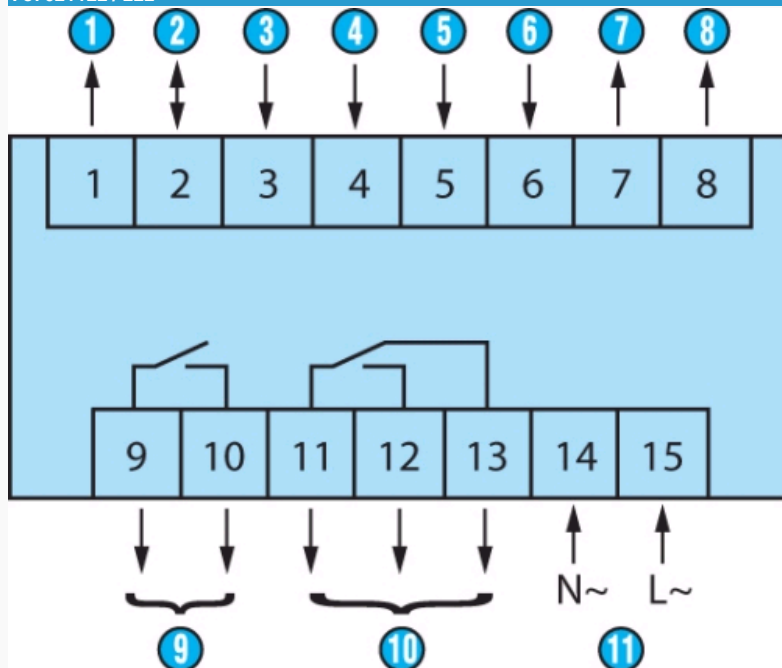

N° Legend

1	Sensor voltage supply
2	GND (0 VDC)
3	INP A (signal A input)
4	INP B (signal B input)
5	Reset (Reset input)
6	Gate input
7	Output 1 : 24 VDC/30 mA
8	Output 2 : 24 VDC/30 mA
9	9-10 : Output 1
10	11-12-13 : Output 2
11	14-15 : Supply

: 87621125 / 225

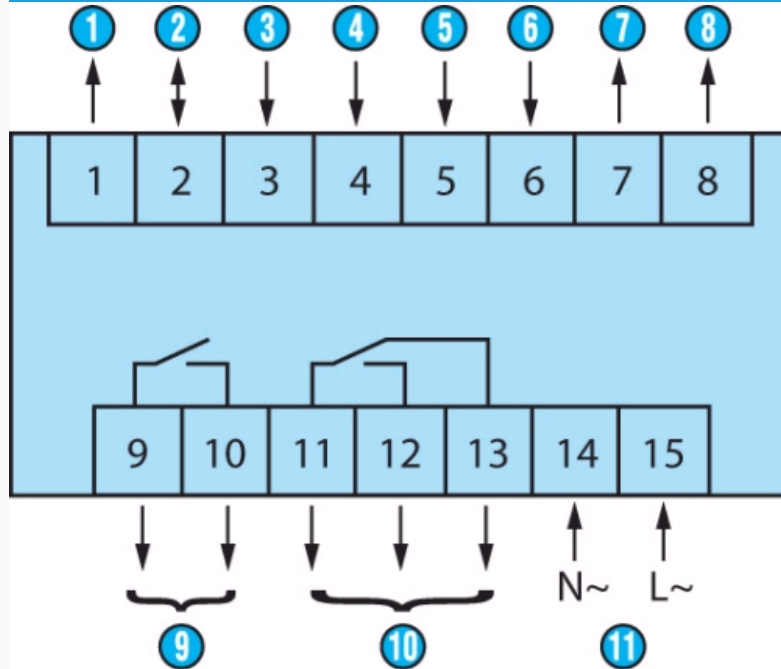

N°	Legend
1	Sensor voltage supply
2	GND (0 VDC)
3	INP A (signal A input)
4	INP B (signal B input)
5	Reset (Reset input)
6	Gate input
7	Output 1 : 24 VDC/30 mA
8	Output 2 : 24 VDC/30 mA
9	9-10 : Output 1
10	11-12-13 : Output 2
11	14-15 : Supply