

DF2005S-G Thru. DF210S-G

Reverse Voltage: 50 to 1000V

Forward Current: 2.0A

RoHS Device

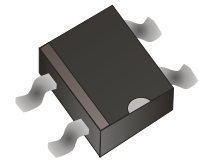

Features

- Rating to 1000V PRV
- Ideal for printed circuit board.
- Low forward voltage drop.
- High current capability.
- The plastic material has UL flammability classification 94V-0
- UL recognized file # E217139

Mechanical Data

- Polarit: As marked on Body
- Weight: 0.02 ounces, 0.38 grams
- Mounting position: Any

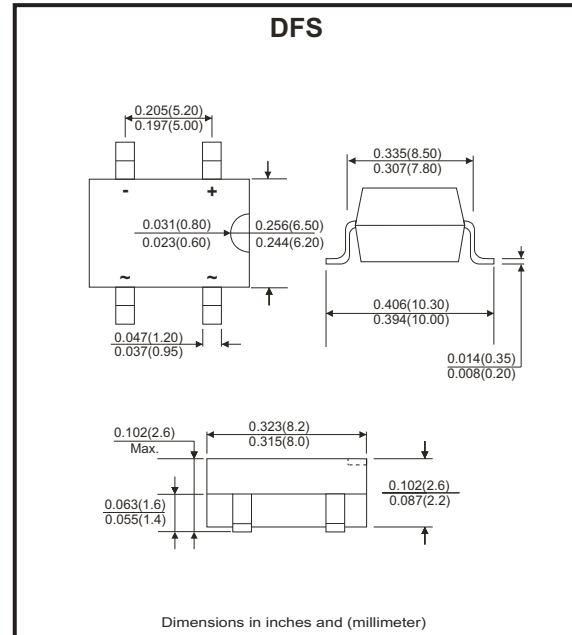

Maximum ratings and electrical characteristics

Rating at 25°C ambient temperature unless otherwise specified.
 Single phase, half wave ,60Hz, resistive or inductive load.
 For capacitive load, derate current by 20%

Parameter	Symbol	DF 2005S-G	DF 2015S-G	DF 2025S-G	DF 2045S-G	DF 2065S-G	DF 2085S-G	DF 2105S-G	Unit
Maximum Recurrent Peak Reverse Voltage	V_{RRM}	50	100	200	400	600	800	1000	V
Maximum RMS Voltage	V_{RMS}	35	70	140	280	420	560	700	V
Maximum DC Blocking Voltage	V_{DC}	50	100	200	400	600	800	1000	V
Maximum Average Forward Rectified Current @ $T_A=40^\circ C$	$I_{(AV)}$	2.0							A
Peak Forward Surge Current, 8.3ms Single Half Sine-Wave Super Imposed On Rated Load (JEDEC Method)	I_{FSM}	60							A
Maximum Forward Voltage at 2.0A DC	V_F	1.1							V
Maximum DC Reverse Current @ $T_J=25^\circ C$ At Rate DC Blocking Voltage @ $T_J=125^\circ C$	I_R	10 500							μA
$I^2 T$ Rating for Fusing ($t < 8.3ms$)	$I^2 t$	10.4							$A^2 s$
Typical Junction Capacitance Per Element (Note 1)	C_J	25							pF
Typical Thermal Resistance (Note 2)	$R_{\theta JA}$	40							$^\circ C/W$
Operating Temperature Range	T_J	-55 to +150							$^\circ C$
Storage Temperature Range	T_{STG}	-55 to +150							$^\circ C$

Notes:

1. Measured at 1.0MHz and applied reverse voltage of 4.0V DC.
2. Thermal resistance from junction to ambient mounted on P.C.B with 0.5*0.5"(13*13mm) copper pads.

Company reserves the right to improve product design , functions and reliability without notice.

REV: F

Rating and Characteristics Curves (DF2005S-G Thru. DF210S-G)

Fig.1 - Derating Curve For Output Rectified Current

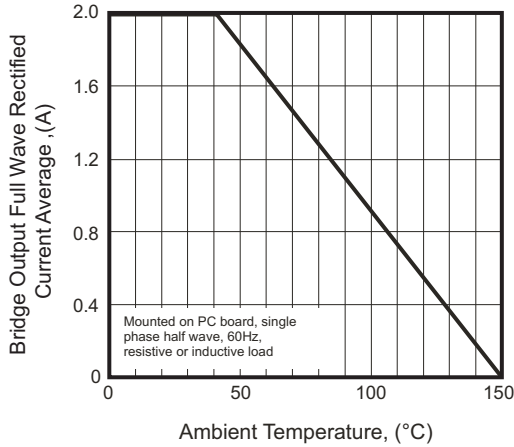

Fig.2 - Maximum Non-Repetitive Peak Forward Surge Current

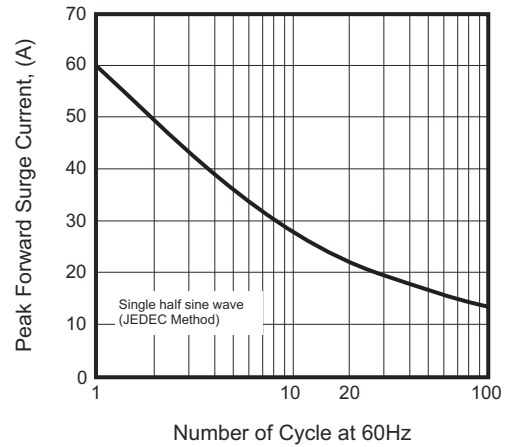

Fig.3 - Typical Junction Capacitance

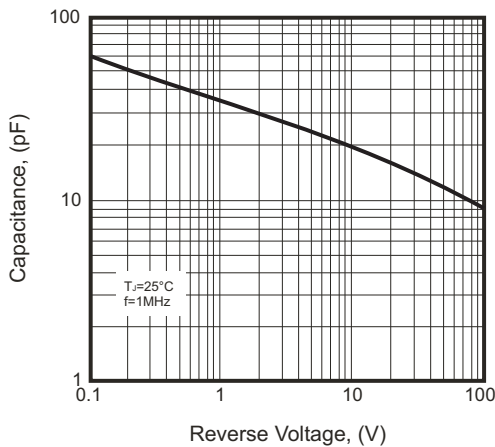

Fig.4 - Typical Forward Characteristics

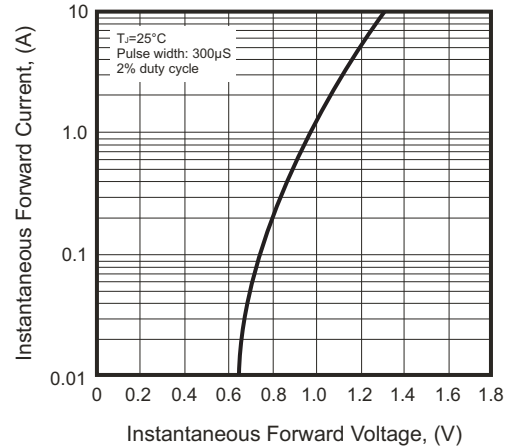
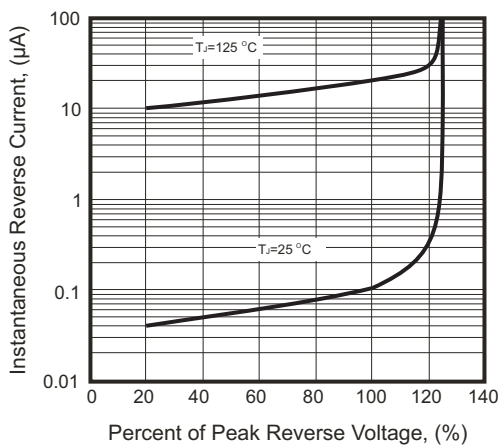

Fig.5 - Typical Reverse Characteristics



Company reserves the right to improve product design, functions and reliability without notice.

REV: F

Reel Taping Specification

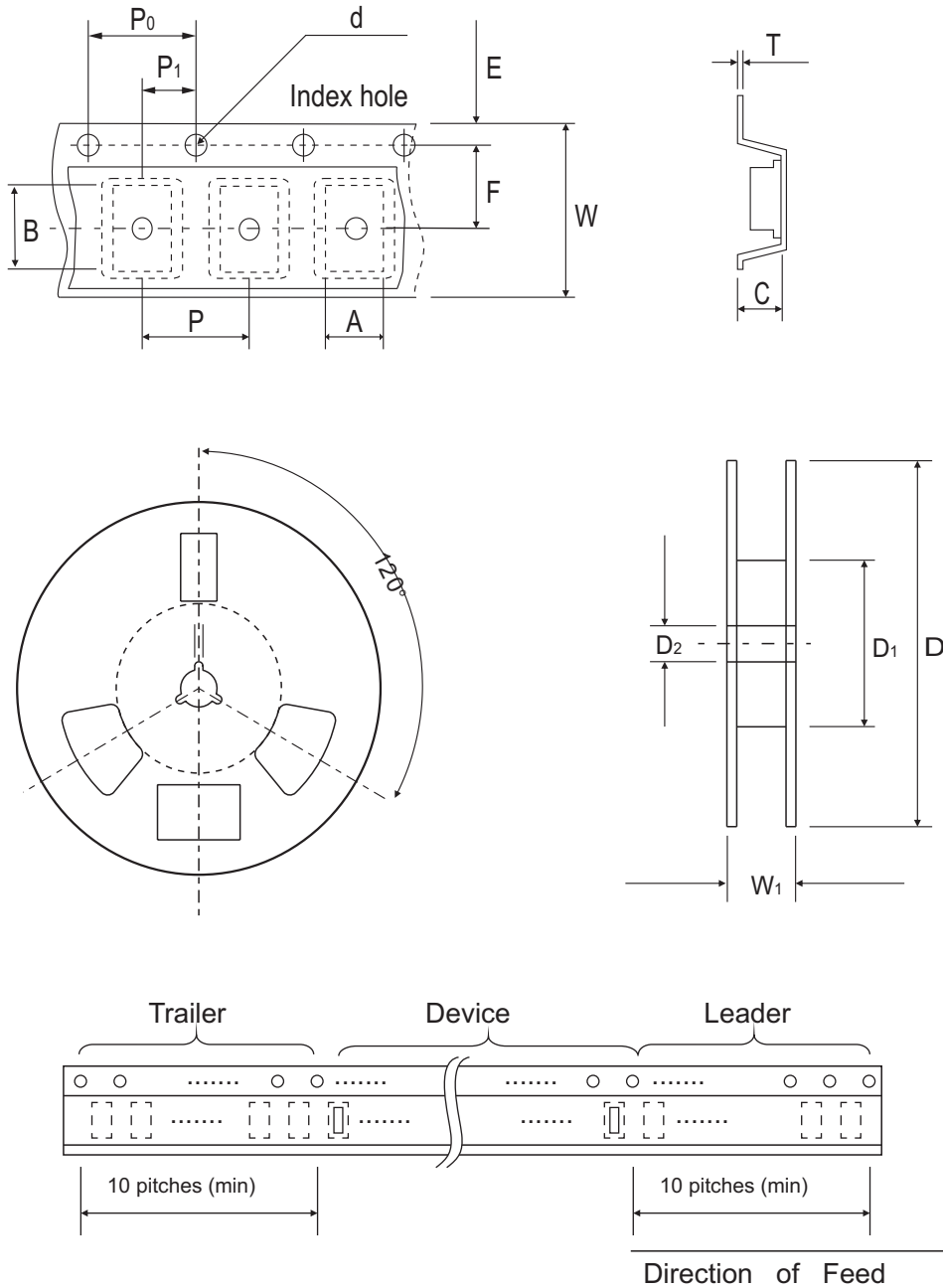

DFS	SYMBOL	A	B	C	d	D	D ₁	D ₂
	(mm)	8.64 ± 0.10	10.41 ± 0.10	3.81 ± 0.10	1.55 ± 0.05	330	50.0 MIN.	13.00 ± 0.20
	(inch)	0.340 ± 0.004	0.409 ± 0.004	0.150 ± 0.004	0.061 ± 0.002	13	1.969 MIN.	0.512 ± 0.008

DFS	SYMBOL	E	F	P	P ₀	P ₁	T	W	W ₁
	(mm)	1.75 ± 0.10	7.50 ± 0.05	12.00 ± 0.10	4.00 ± 0.10	2.00 ± 0.10	0.32	16.00 ± 0.30	16.00~18.40
	(inch)	0.069 ± 0.004	0.295 ± 0.002	0.472 ± 0.004	0.157 ± 0.004	0.079 ± 0.004	0.013	0.630 ± 0.012	0.630~0.724

Company reserves the right to improve product design, functions and reliability without notice.

REV: F

Marking Code

Part Number	Marking code	Packaging
DF2005SP-G	DF2005S	Tube
DF201SP-G	DF201S	Tube
DF202SP-G	DF202S	Tube
DF204SP-G	DF204S	Tube
DF206SP-G	DF206S	Tube
DF208SP-G	DF208S	Tube
DF210SP-G	DF210S	Tube
DF2005ST-G	DF 2005S	Reel
DF201ST-G	DF201S	Reel
DF202ST-G	DF202S	Reel
DF204ST-G	DF204S	Reel
DF206ST-G	DF206S	Reel
DF208ST-G	DF208S	Reel
DF210ST-G	DF210S	Reel

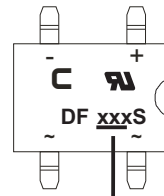

XXX / XXXX = Product type marking code
C = Comchip Logo

Note:

1) Suffix code after part number to specify packaging item .

Packaging	Code
TUBE PACK	P
REEL PACK	T

Suggested PAD Layout

SIZE	DFS	
	(mm)	(inch)
A	1.20 Min	0.047 Min
B	5.21 REF	0.205 REF
C	1.52 Min	0.060 Min
D	10.26 Max	0.404 Max

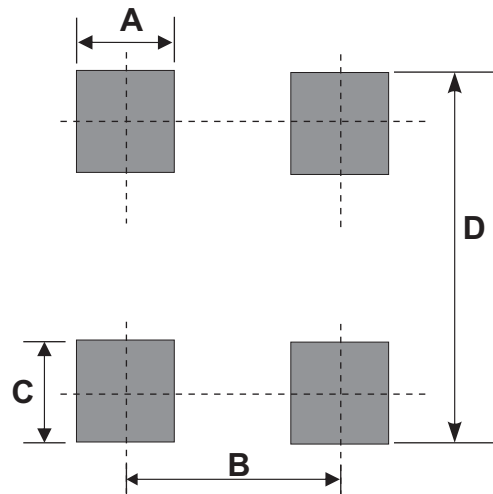

Standard Packaging

Case Type	TUBE PACK	
	TUBE (pcs)	Carton (pcs)
DFS	50	10,000

Case Type	REEL PACK	
	REEL (pcs)	Reel Size (inch)
DFS	1,000	13

Company reserves the right to improve product design , functions and reliability without notice.

REV: F