

Surface Mount Switching Diode

COMCHIP
www.comchip.com.tw

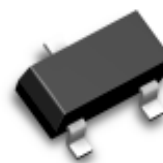

BAV99 Thru BAW56 Voltage: 70 Volts Current: 215mA



Features

- Fast Switching Speed
- Surface Mount Package Ideally Suited for Automatic Insertion
- For General Purpose Switching Applications
- High Conductance

Mechanical data

Case: SOT-23, Plastic
Approx. Weight: 0.008 gram

This diodes is also available in other configurations including a dual common cathode with type designation BAV70, a dual common anodes with type designation BAW56 and single chip inside with type Designation BAL99

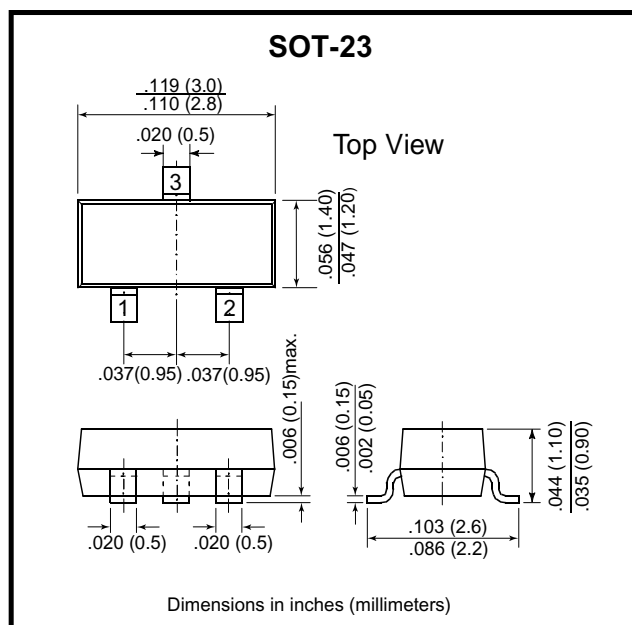
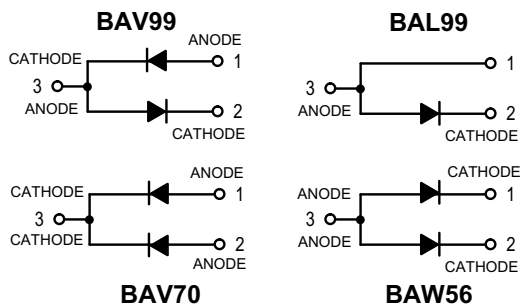

Maximum Ratings

Rating	Symbol	Value	Units
Continuous Reverse Voltage	V_R	70	V_{DC}
Peak Forward Current	I_F	215	mAdc
Peak Forward Surge Current	$I_{FM(surge)}$	500	mAdc

Thermal Characteristics

Characteristic	Symbol	Max	Units
Total Device Dissipation FR-5 Board(1) $T_A = 25^\circ C$	P_D	225	mW
Derate above $25^\circ C$		1.8	mW/ $^\circ C$
Thermal Resistance, Junction to Ambient	$R_{\theta JA}$	556	$^\circ C/W$
Total Device Dissipation Alumina Substrate.(2) $T_A = 25^\circ C$	P_D	300	mW
Derate above $25^\circ C$		2.4	mW/ $^\circ C$
Thermal Resistance, Junction to Ambient	$R_{\theta JA}$	417	$^\circ C/W$
Junction and Storage Temperature	T_J, T_{stg}	-55 to +150	$^\circ C$

Electrical Characteristics (TA = 25°C unless otherwise noted)

Characteristic (OFF CHARACTERISTICS)	Symbol	Min	Max	Units
Reverse Breakdown Voltage ($I_{BR} = 100 \mu A_{dc}$)	$V_{(BR)}$	70	-	Vdc
Reverse Voltage Leakage Current $V_R = 25 V_{dc}, T_J = 150^\circ C$	I_R	-	30	μA_{dc}
		$V_R = 70 V_{dc}$	2.5	
		$V_R = 70 V_{dc}, T_J = 150^\circ C$	50	
Diode Capacitance ($V_R = 0, f = 1.0 MHz$)	C_D		1.5	pF
Forward Voltage $I_F = 1.0 mA_{dc}$	VF	-	715	mV
		$I_F = 10 mA_{dc}$	855	
		$I_F = 50 mA_{dc}$	1000	
		$I_F = 150 mA_{dc}$	1250	
Reverse Recovery Time ($I_F = I_R = 10 mA_{dc}, I_{R(REC)} = 1.0 mA_{dc}$) $R_L = 100 \Omega$	T_{rr}		6.0	nS

1.FR-5 = 1.0 X 0.75X 0.062 in. 2.Alumina = 0.4X 0.3X 0.024 in. 99.5% aluminum.

Surface Mount Switching Diode

RATING AND CHARACTERISTIC CURVES (BAV99 Thru BAW56)

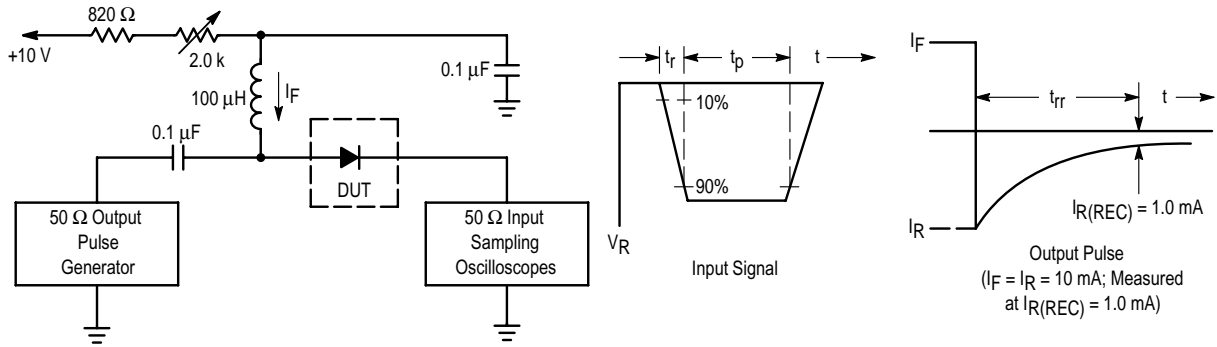

- Notes: 1. A 2.0 kΩ variable resistor adjusted for a Forward Current (I_F) of 10 mA.
2. Input pulse is adjusted so $I_{R(peak)}$ is equal to 10 mA.
3. $t_p \gg t_{rr}$

Figure 1. Recovery Time Equivalent Test Circuit

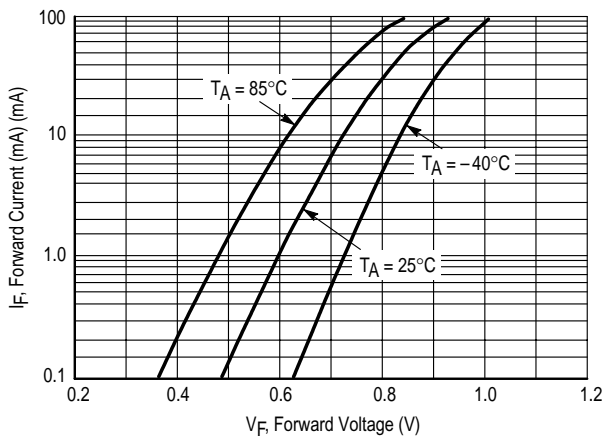

Figure 2. Forward Voltage

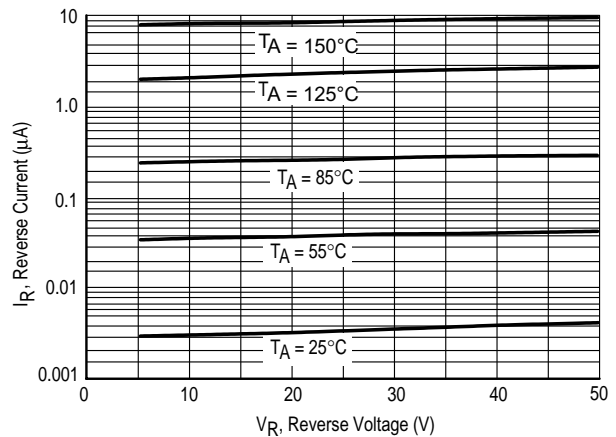

Figure 3. Leakage Current

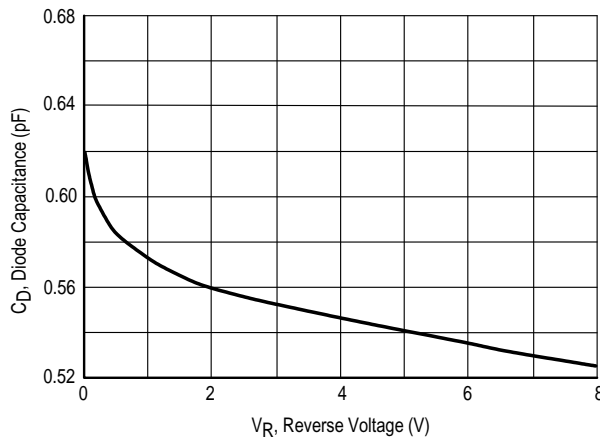

Figure 4. Capacitance