

# AMGP-6432

## 28-31 GHz 2W SMT Packaged Power Amplifier



### Data Sheet



#### Description

The AMGP-6432 is a surface mount packaged 2-Watt power amplifier that operates from frequencies between 28 to 31 GHz. In the operational frequency band from 29.25 to 30 GHz, it provides 33 dBm of typical output power ( $P_{1dB}$ )/ 34 dBm  $P_{sat}$  and 21.5dB of small-signal gain. This PA is also suitable for high linear application where the PA demonstrates greater than -38dBc of third order output inter modulation (OIM3) at +18dBm/ tone output power level.

#### Features

- 5 x 5 mm surface mount package
- > +33 dBm Output Power from 28.5 to 31 GHz
- 50  $\Omega$  input and output match
- -40° C to +85° C operation

#### Functional Block Diagram

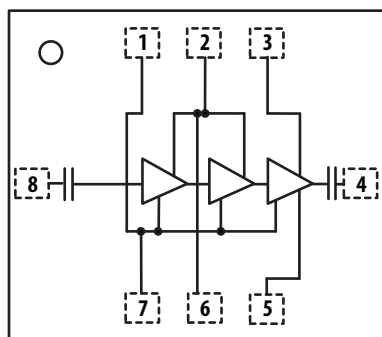

Pin	Function
1	Vg
2	Vd1
3	Vd2
4	RF_OUT
5	Vd2
6	Vd1
7	Vg
8	RF_IN

#### Applications

- VSAT
- Microwave Radio System
- Satellite Up/Down Link

**Export License Control:** ECCN 3A001.b.2.c

#### Package Diagram

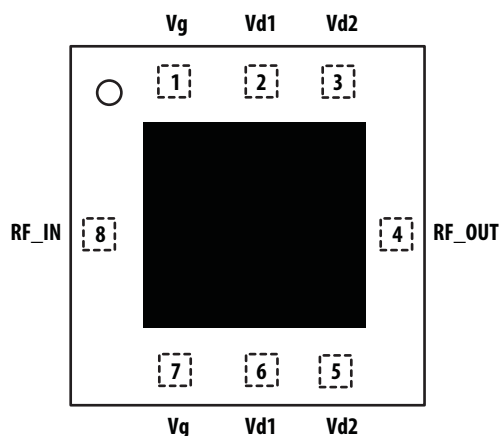

**Attention: Observe Precautions for handling electrostatic sensitive devices.**  
 ESD Machine Model (Class A): 60 V  
 ESD Human Body Model (Class 1A): 200 V  
 Refer to Avago Application Note A004R:  
 Electrostatic Discharge Damage and Control.

## ELECTRICAL SPECIFICATIONS

**Table 1. Absolute Minimum and Maximum [1] Ratings**

Parameter	Specifications			Comments	
Description	Pin	Min.	Max.	Unit	
Drain Supply Voltage	V <sub>d1</sub> V <sub>d2</sub>		6.5	V	
Gate Supply Voltage	V <sub>g</sub>	-2	0	V	
RF Input Power (P <sub>in</sub> ) [2]	RFIN		24	dBm	CW
Power Dissipation (P <sub>diss</sub> )			10	W	P <sub>diss</sub> = V <sub>d1</sub> × I <sub>d1</sub> + V <sub>d2</sub> × I <sub>d2</sub> + P <sub>in</sub> - P <sub>out</sub>
MSL			MSL2		
T <sub>CH</sub>			150	°C	Channel Temperature
T <sub>STG</sub>		-65	150	°C	Storage Temperature

Notes:

1. Operation of this device above any one of these maximum parameters may cause permanent damage
2. With the DC (typical bias) and RF applied to the device at board temperature T<sub>b</sub> = 25° C

**Table 2. Recommended Operating Range**

Parameter	Specifications					Comments
Description	Pin	Min.	Typical	Max.	Unit	Comments
Drain Supply Voltage	V <sub>d1</sub> V <sub>d2</sub>		6.0		V	
Gate Supply Voltage	V <sub>g</sub>	-0.1	-0.83	-0.6	V	
Maximum Gate Current	I <sub>g, max</sub>	-3	-2.5		mA	I <sub>g, max</sub> occurs at highest RF P <sub>out</sub> condition.
Quiescent Drain Supply Current (I <sub>dq</sub> )	V <sub>d1</sub> V <sub>d2</sub>		300 400		mA	I <sub>dq</sub> = I <sub>d1</sub> + I <sub>d2</sub>
RF Output Power (P <sub>out</sub> )	RFOUT		33		dBm	CW
Frequency Range		28		31	GHz	
Thermal Resistance, θ <sub>ch-b</sub>			7.6		°C/W	Channel to board
Base Plate Temperature		-40		+85	°C	
ESD	Human Body Model		200		V	
	Machine Model		60		V	

## Electrical Specifications

All data measured on a 2.4 mm connectorized production contactor board (Rogers 4350B) at  $V_{dd1} = V_{dd2} = 6\text{ V}$ ,  $I_{dq} = 0.7\text{ A}$  ( $I_{dq1} + I_{dq2}$ ),  $T_c = 25^\circ\text{ C}$ , and  $50\ \Omega$  at all ports unless otherwise stated

**Table 3. RF Electrical Characteristics**

Parameter	Performance			Unit	Comments
	Min.	Typical	Max.		
Frequency Range (GHz)	28		31	GHz	
Input Return Loss (dB)		-15		dB	Small Signal
Output Return Loss (dB)		-12		dB	Small Signal
Gain (dB) <sup>[1]</sup> @ Freq = 29.25 GHz	18	21.5	25	dB	$V_{dd} = 6\text{ V}$ , $I_{dq} = 0.7\text{ A}$
( $P_{in} = 0\text{ dBm}$ ) @ Freq = 30 GHz	18	21.3	25		$V_{dd} = 6\text{ V}$ , $I_{dq} = 0.7\text{ A}$
Reverse Isolation (dB)		-50		dB	Small Signal
$P_{out}$ <sup>[1]</sup> @ Freq = 29.25 GHz	33	34.8		dBm	$V_{dd} = 6\text{ V}$ , $I_{dq} = 0.7\text{ A}$
( $P_{in} = 17\text{ dBm}$ ) @ Freq = 30 GHz	33	34.3			$V_{dd} = 6\text{ V}$ , $I_{dq} = 0.7\text{ A}$
$P_{1dB}$ <sup>[2]</sup> @ Freq = 29.25 GHz	32	33.9			$V_{dd} = 6\text{ V}$ , $I_{dq} = 0.7\text{ A}$
@ Freq = 30 GHz	32	32.9			$V_{dd} = 6\text{ V}$ , $I_{dq} = 0.7\text{ A}$
IM3 Level		-38		dBc	$\Delta f = 20\text{ MHz}$ , $P_{out} = 20\text{ dBm/tone}$
Total Drain Current	1.25	1.4	1.55	A	$I_{dd}$

Note:

1.  $P_{out}$  & Gain measurement accuracy is subjected to the tolerance of  $\pm 0.5\text{ dBm}$  respectively.
2. Guaranteed by design

**Product Consistency Distribution Charts at 29.25 GHz and 30 GHz,  $V_{dd} = 6\text{ V}$ ,  $I_{dq} = 0.7\text{ A}$**

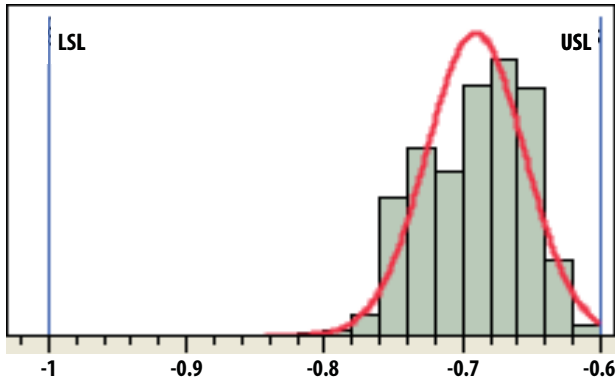

$V_g @ V_{dd} = 6\text{ V}, I_{dq} = 0.7\text{ A}$ , Mean = -0.68 V, LSL = -1 V, USL = -0.6 V

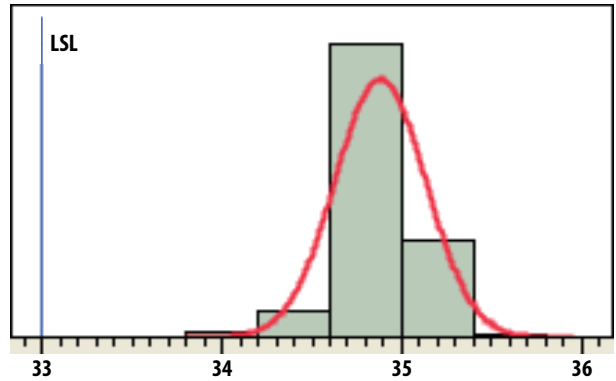

$P_{out} @ 29.25\text{ GHz} (P_{in} = 17\text{ dBm})$ , Mean = 34.8 dBm, LSL = 33 dBm

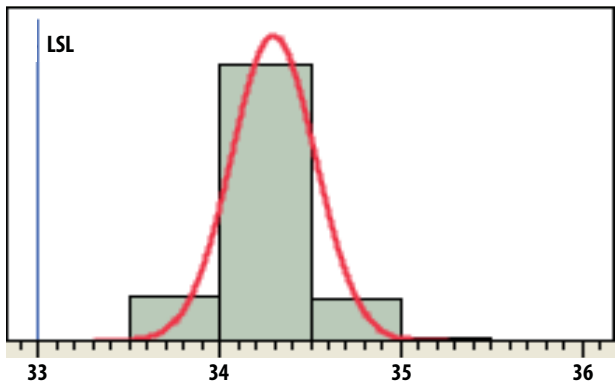

$P_{out} @ 30\text{ GHz} (P_{in} = 17\text{ dBm})$ , Mean = 34.3 dBm, LSL = 33 dBm

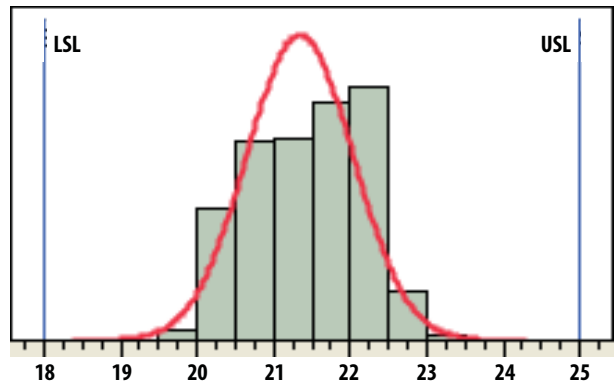

Gain @ 29.25 GHz, Mean = 21.5 dB, LSL = 18 dB, USL = 25 dB

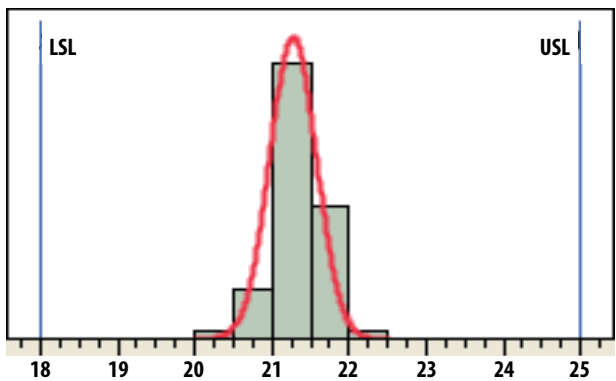

Gain @ 30 GHz, Mean = 21.2 dB, LSL = 18 dB, USL = 25 dB

## Selected Performance Plots

All data measured on a 2.4 mm connector based evaluation board at  $V_{dd1} = V_{dd2} = 6\text{ V}$ ,  $I_{dq} = 0.7\text{ A}$  ( $I_{d1} + I_{d2}$ ),  $T_A = 25^\circ\text{ C}$ , and  $50\ \Omega$  at all ports.

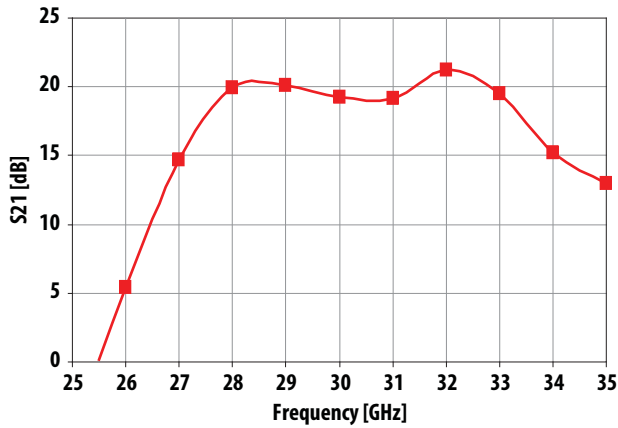

Figure 1. S<sub>21</sub> (dB) Frequency Sweep

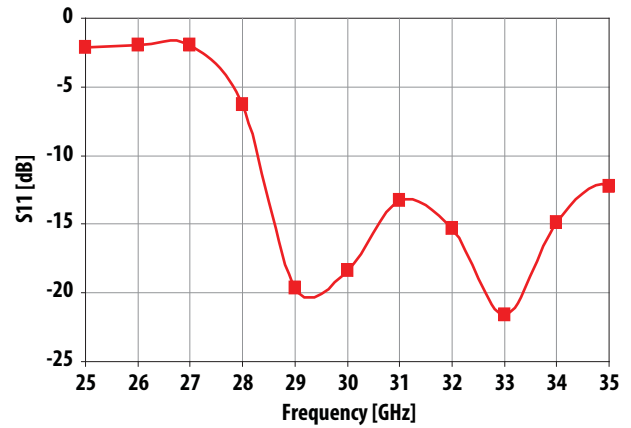

Figure 2. S<sub>11</sub> (dB) Frequency Sweep

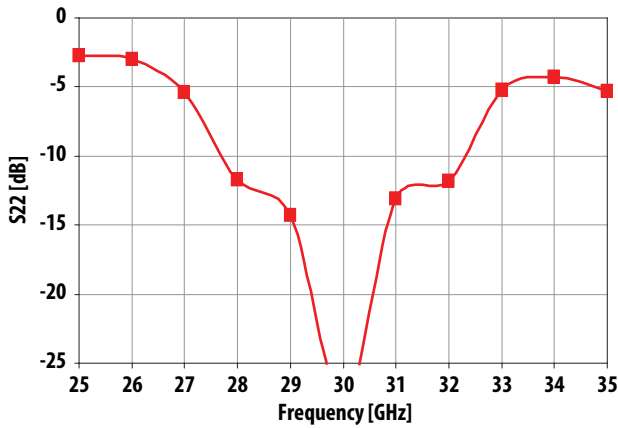

Figure 3. S<sub>22</sub> (dB) Frequency Sweep

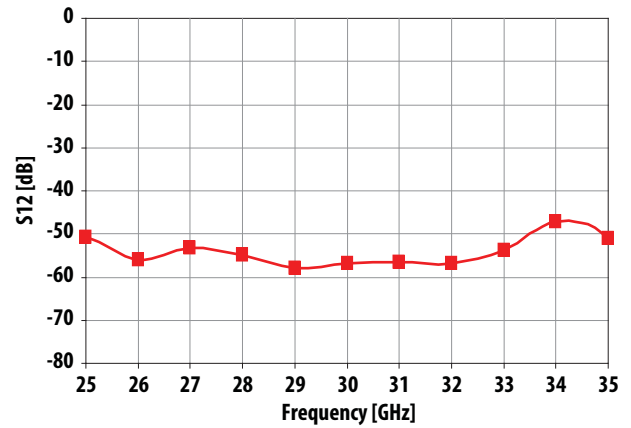

Figure 4. S<sub>12</sub> (dB) Frequency Sweep

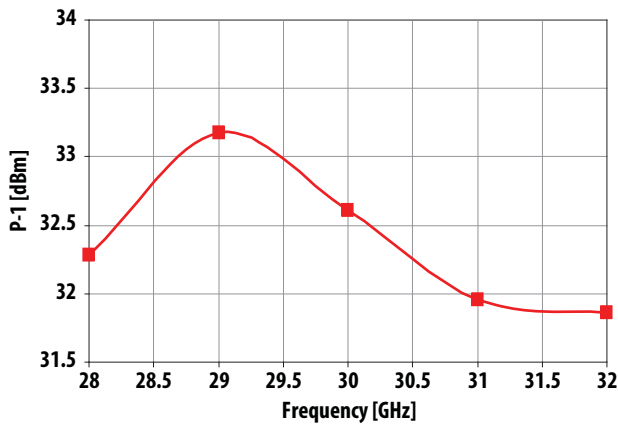

Figure 5. P<sub>1dB</sub> (dBm) Frequency Sweep

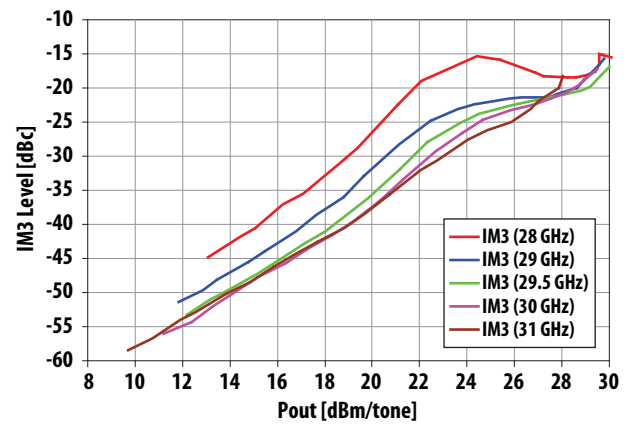

Figure 6. IM3 level (dBc) vs. Output power/tone

## Selected Performance Plots over Operating Temperature Range

All data measured on a 2.4 mm connector based evaluation board at  $V_{dd1} = V_{dd2} = 6\text{ V}$ ,  $I_{dq} = 0.7\text{ A}$  ( $I_{d1} + I_{d2}$ ), and  $50\ \Omega$  at all ports.  $I_{dq}$  has been maintained at  $0.7\text{ A}$  under different temperature conditions. Plotted data shown this page includes evaluation board loss and connector loss approximately  $0.5\text{ dB/one side}$ .

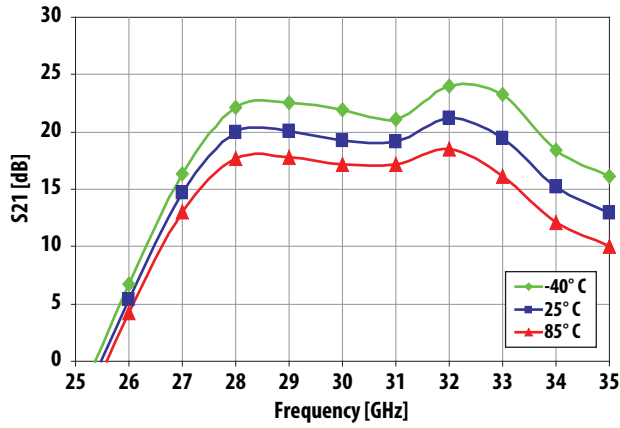

Figure 7.  $S_{21}$  (dB) Frequency Sweep over Temperature

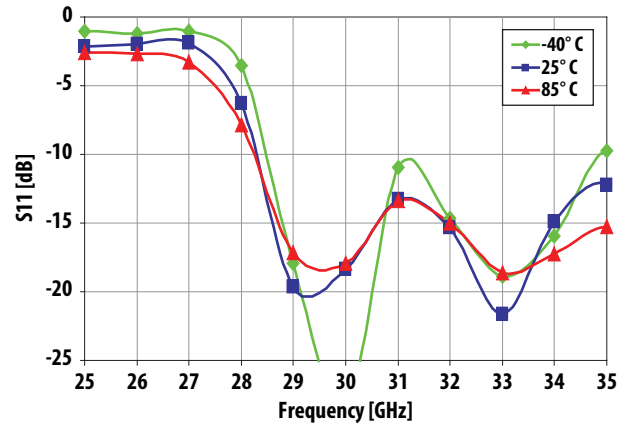

Figure 8.  $S_{11}$  (dB) Frequency Sweep over Temperature

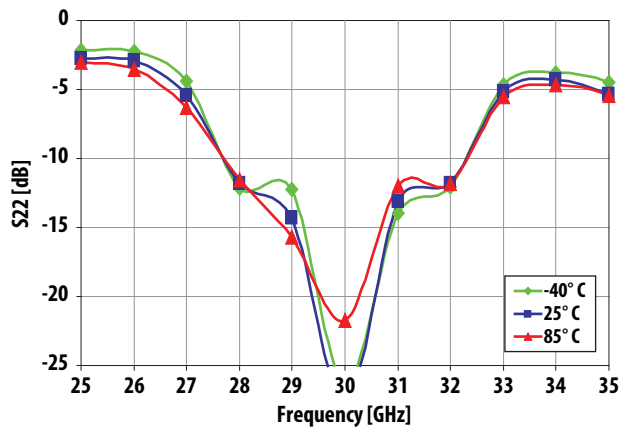

Figure 9.  $S_{22}$  (dB) Frequency Sweep over Temperature

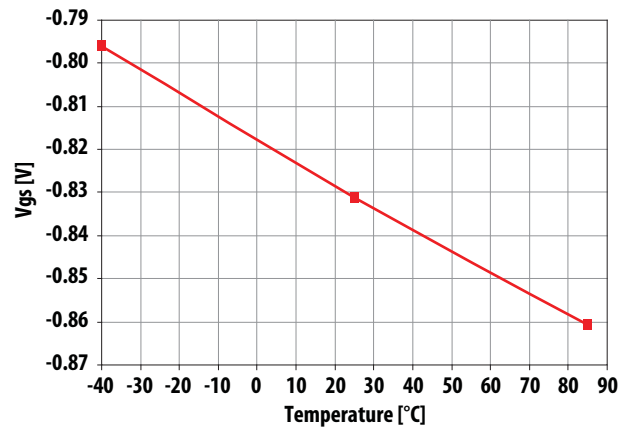

Figure 10. Typical  $V_{gs}$  for  $I_{dq} = 0.7\text{ A}$  over Temperature

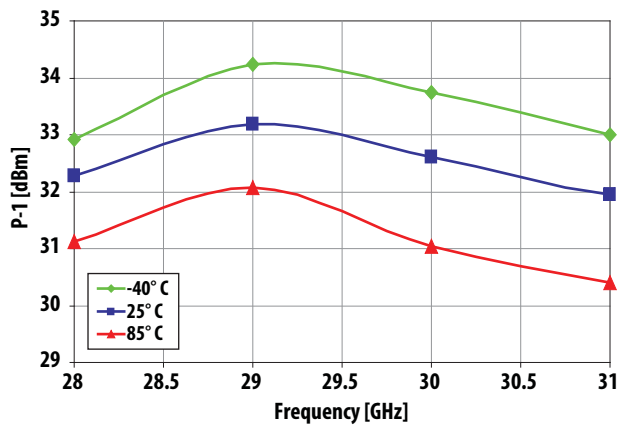

Figure 11.  $P_{1dB}$  (dBm) Frequency Sweep over Temperature

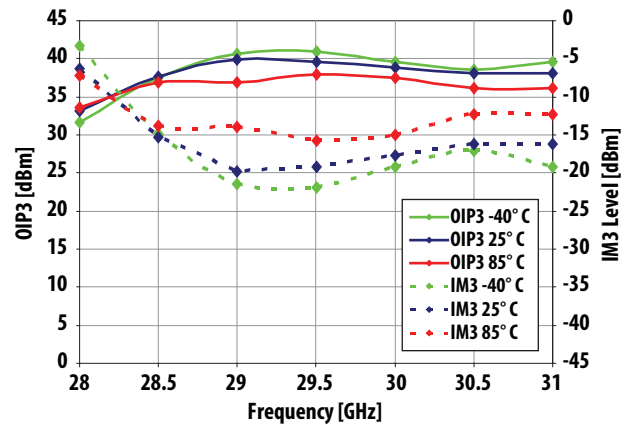

Figure 12. OIP3 (dBm) and IM3 level (dBm) Frequency Sweep over Temperature @  $P_o = 20\text{ dBm/tone}$

## Selected Performance Plots Over Operating Supply Voltage Range

All data measured on a 2.4 mm connector based evaluation board at  $T_A = 25^\circ\text{C}$ , and  $50\ \Omega$  at all ports. Plotted data shown this page includes evaluation board loss and connector loss approximately 0.5 dB/one side.

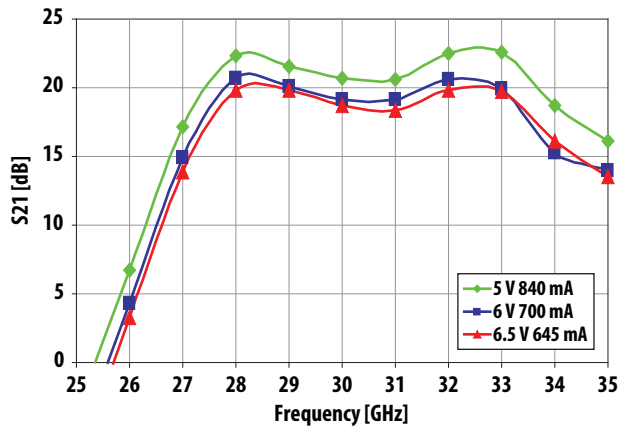

Figure 13.  $S_{21}$  (dB) Frequency Sweep

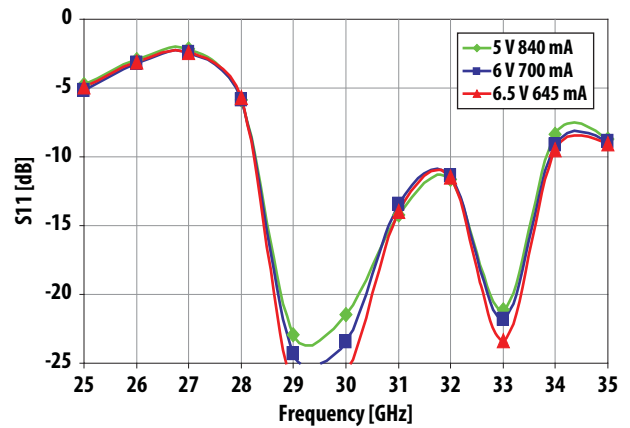

Figure 14.  $S_{11}$  (dB) Frequency Sweep

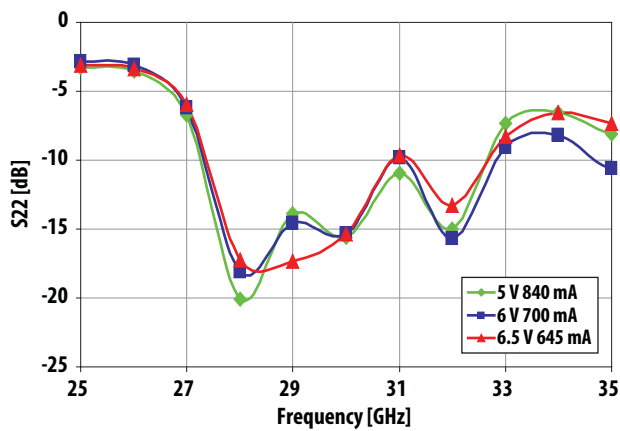

Figure 15.  $S_{22}$  (dB) Frequency Sweep

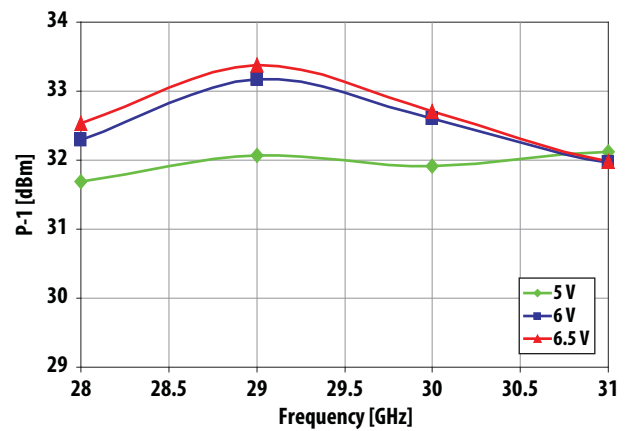

Figure 16.  $P_{1dB}$  (dBm) Frequency Sweep

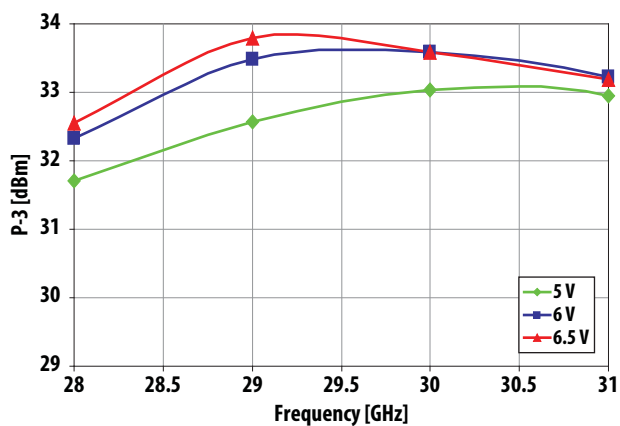

Figure 17.  $P_{3dB}$  (dBm) Frequency Sweep

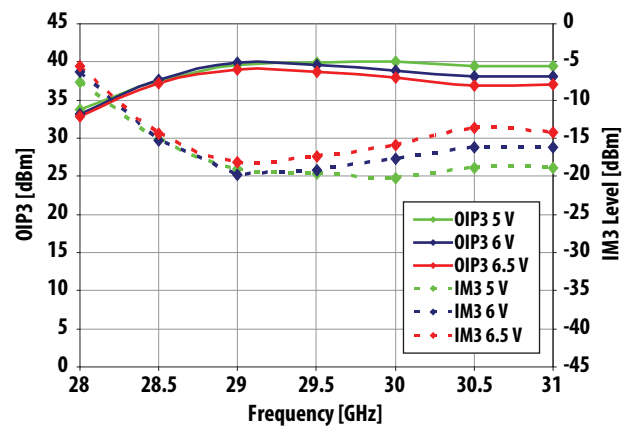

Figure 18. OIP3 and IM3 level vs. Frequency Sweep @  $P_o = 20\ \text{dVm/tone}$

## Reliability Data

Please contact Avago Technical and/or Customer supports for more detail [www.avagotech.com](http://www.avagotech.com)

## Evaluation Board Description

### Demo-board Pins

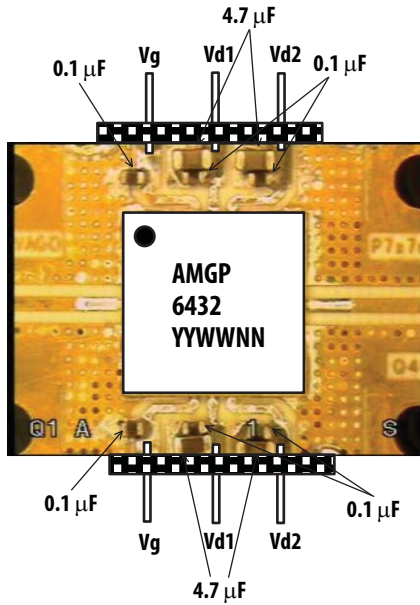

Notes:

1. Vd1 and Vd2 must be biased from both sides.
2. Vg can be biased from either side.

Figure 19. Demo Unit

Table 4. Typical Test Conditions:

PIN		
V <sub>d1,2</sub>	6 V	Drain Supply Voltage
I <sub>dq</sub> = I <sub>d1</sub> + I <sub>d2</sub>	0.7 A	Quiescent Drain Current
V <sub>g</sub>	-0.83 V	Gate Supply Voltage

Notes: V<sub>g</sub> of -0.83 V may need be adjusted to obtain I<sub>dq</sub> = 0.7 A.

### Demo board circuit

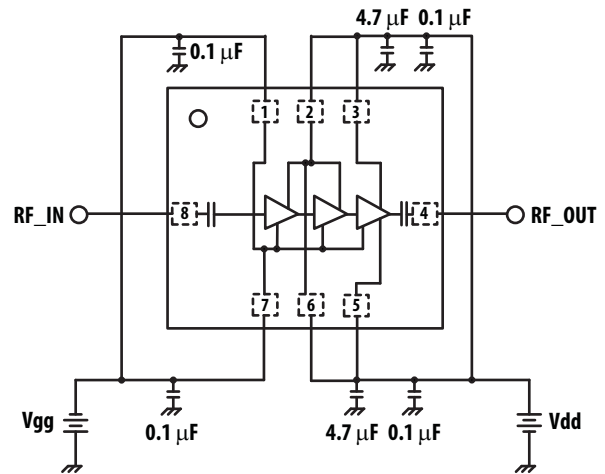

Notes:

1. Vg pins can be biased from either side.
2. Vd pins must be biased from both sides.

Figure 20. Application Circuit

### Recommended turn on sequence

- Apply V<sub>g</sub> at -1.5 V
- Apply V<sub>d1</sub> and V<sub>d2</sub> at 0 V
- Increase V<sub>d</sub> to 6 V
- Increase V<sub>g</sub> of -1.5 V to approximately -0.83 V to obtain I<sub>dq</sub> = 0.7 A
- Apply RF Input not to exceed 20 dBm
- Turn off in reverse order



## Package Dimension, PCB Layout and Tape and Reel information

Please refer to Avago Technologies Application Note 5520, AMxP-xxxx production Assembly Process (Land Pattern A).

## Part Number Ordering Information

Part Number	Devices per Container	Container
AMGP-6432-BLKG	10	antistatic bag
AMGP-6432-TR1G	100	7" Reel
AMGP-6432-TR2G	500	7" Reel

For product information and a complete list of distributors, please go to our web site: [www.avagotech.com](http://www.avagotech.com)

Avago, Avago Technologies, and the A logo are trademarks of Avago Technologies in the United States and other countries. Data subject to change. Copyright © 2005-2012 Avago Technologies. All rights reserved.  
AV02-3203EN - May 14, 2012

