

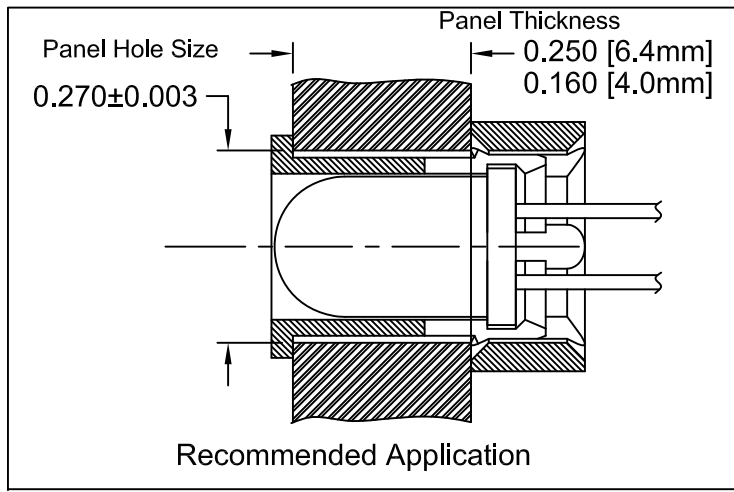

ITEM	Q'TY	PART NUMBER	PART DESCRIPTION
1	1	C-174L	T-1¼ (5mm) LED CLIP
2	1	R-174	T-1¼ (5mm) LED RING

REV.	DESCRIPTION	DATE	APPROVED
C	Engineering Update w/o Changes	02/26/04	M. C.
D	Corrected BOM, LED size from 3mm to 5mm	02/05/14	J. C.
E	Typo Correction	11/05/14	J. C.

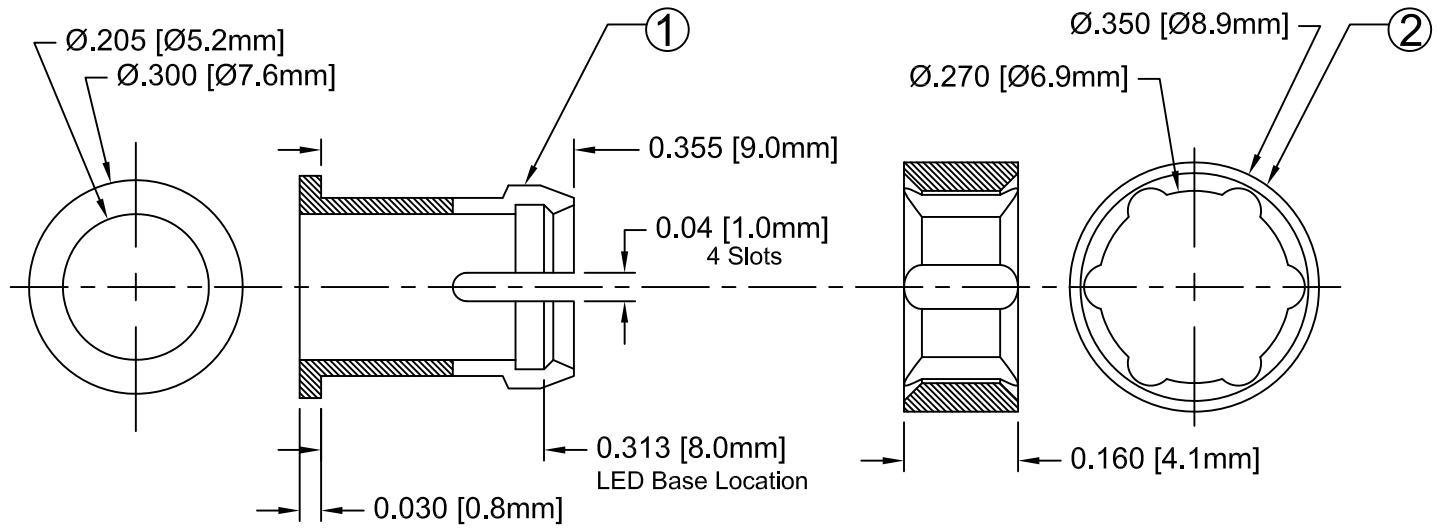

2. MATERIAL: NYLON 6/6, 94V-2, BLACK.

1. GENERAL SPECIFICATIONS: BIVAR MOLDED COMPONENT SPECIFICATION BV00-E101.

STANDARD TOLERANCE (UNLESS OTHERWISE SPECIFIED)		 4 THOMAS, IRVING, CA, 92618 TEL: (949) 951-8808 FAX: (949) 951-3974	
DECIMALS	ANGULAR		
.X ± .1	X° ± 1°	 TITLE: T-1¼ LED CLIP & RING SET	
.XX ± .01			
.XXX ± .005			
DESIGNED: Shane Irving	DATE: 11/24/98	PART NO: CR-174L	REVISION: E
CHECKED: M. Chen	DATE: 05/17/02	CAGE CODE : 32559	SHEET # 1 OF 1
CAD GENERATED DOCUMENT, DO NOT MEASURE DRAWING.			