

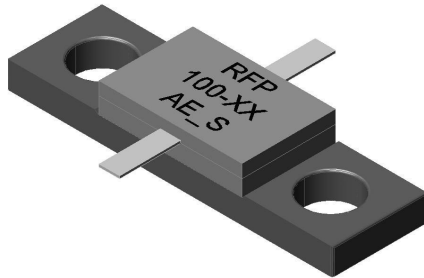

Full Flange Attenuators 100 Watts



General Specifications

Resistive Element	Thick film
Substrate	Beryllium oxide ceramic
Cover	Alumina Ceramic
Mounting Flange	Copper, Nickel plated per QQ-N-290
Lead(s):	99.99% pure silver (.006" thick)
Operating Temperature	-55 to +150°C (see chart)

Features:

- DC – See table
- 100 Watts
- BEO Ceramic
- Welded Silver Leads
- Non-Nichrome Resistive Element
- Low VSWR
- 100% Tested

Electrical Specifications

Attenuation Range:	1, 2, 3, 4, 5, 6, 9, 10, 20, 22 or 30 dB
Frequency Range:	DC – See Chart
Power:	100 Watts
V.S.W.R.:	See Chart

Notes: Tolerance is ± 0.010 ", unless otherwise specified. Designed to meet or exceed applicable portions of MIL-E-5400. All dimensions in inches. Lead length 0.150" minimum.

Specifications subject to change without notice.

Outline Drawing

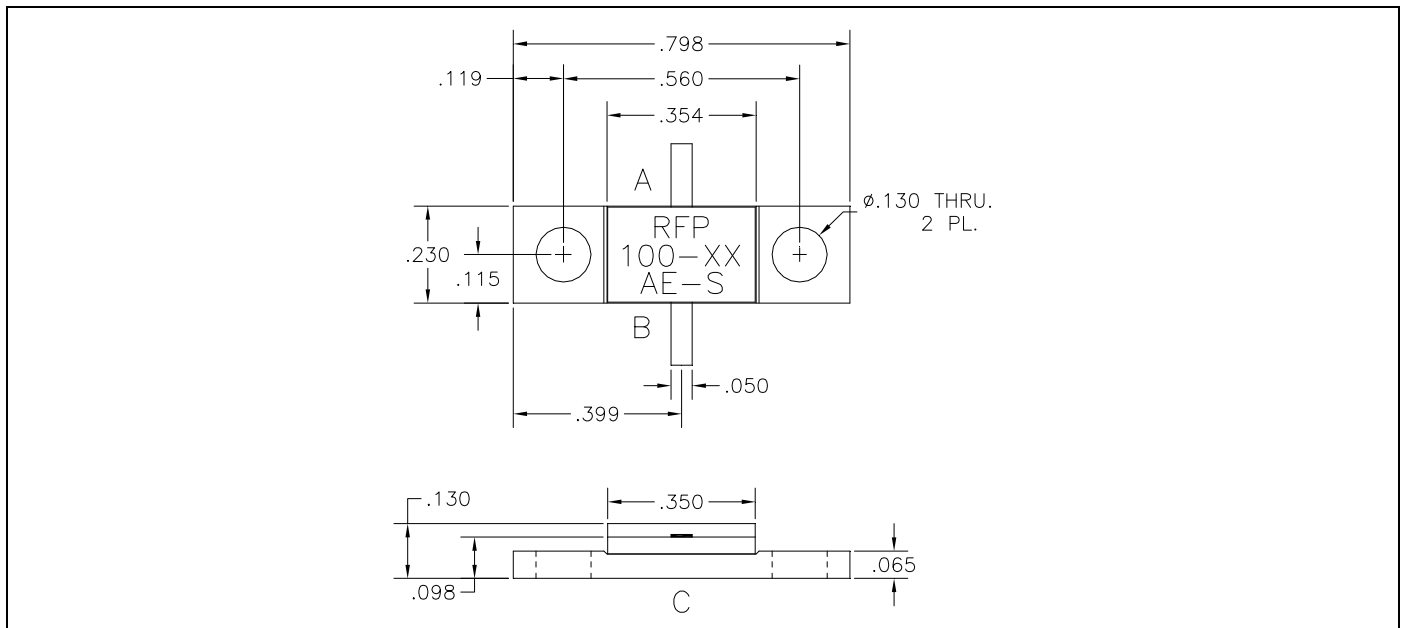

100-XXAE-S (097) Rev B



Specifications

PART NUMBER	ATTENUATION	VALUE (A-B)	VALUE (A-C)	VALUE (B-C)	TOL.	VSWR	FREQ. (GHz)
RFP-100-1AE-S	1 db ± 0.4	5.8 Ω	435.9 Ω	435.9 Ω	± 4%	1.45:1	DC -1 GHz
RFP-100-2AE-S	2 db ± 0.4	11.4 Ω	220.7 Ω	220.7 Ω	± 4%	1.40:1	DC -1 GHz
RFP-100-3AE-S	3 db ± 0.4	17.0 Ω	150.5 Ω	150.5 Ω	± 4%	1.35:1	DC -1 GHz
RFP-100-4AE-S	4 db ± 0.3	22.6 Ω	116.3 Ω	116.3 Ω	± 4%	1.30:1	DC -1 GHz
RFP-100-5AE-S	5 db ± 0.3	28.0 Ω	96.0 Ω	96.0 Ω	± 4%	1.25:1	DC -1 GHz
RFP-100-6AE-S	6 db ± 0.3	32.2 Ω	83.6 Ω	83.6 Ω	± 4%	1.20:1	DC -1 GHz
RFP-100-9AE-S	9 db ± 0.3	47.6 Ω	64.4 Ω	64.4 Ω	± 4%	1.20:1	DC -1 GHz
RFP-100-10AE-S	10 db ± 1.2	52.0 Ω	61.0 Ω	61.0 Ω	± 4%	1.25:1	DC -2 GHz
RFP-100-20AE-S	20 db ± 0.5	81.7 Ω	50.9 Ω	50.9 Ω	± 4%	1.20:1	DC -2.5 GHz
RFP-100-22AE-S	22 db ± 0.5	85.3 Ω	50.6 Ω	50.6 Ω	± 4%	1.20:1	DC -1 GHz
RFP-100-30AE-S	30 db ± 2.0	92.5 Ω	49.6 Ω	49.6 Ω	± 4%	1.20:1	DC -2 GHz

Suggested Mounting Procedure

.025 MIN. (2 PLACES)
 BOARD LOWER THAN LEAD. BOARD EVEN WITH LEAD. BOARD LOWER THAN LEAD. BOARD HIGHER THAN LEAD.

SUGGESTED STRESS RELIEF METHODS NOT RECOMMENDED APPLICATION
 SCALE: NONE SCALE: NONE

SUGGESTED MOUNTING PROCEDURES:

1. MAKE SURE THAT THE DEVICES ARE MOUNTED ON FLAT SURFACES (.001" UNDER THE DEVICE) TO OPTIMIZE THE HEAT TRANSFER.
2. POSITION DEVICE ON MOUNTING SURFACE AND SOLDER IN PLACE USING APPROPRIATE TYPE SOLDER.
3. SOLDER LEADS IN PLACE USING APPROPRIATE TYPE SOLDER WITH A CONTROLLED TEMPERATURE IRON.

Power Derating

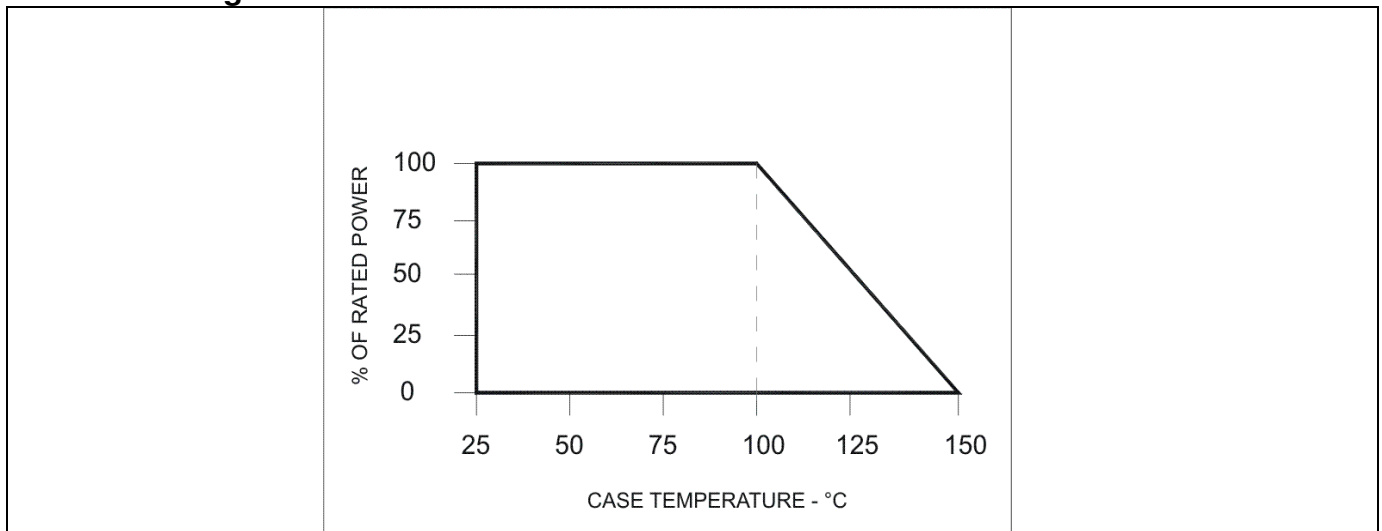

100-XXAE-S (097) Rev B

USA/Canada:
Toll Free:
Europe:

(315) 432-8909
(800) 544-2414
+44 2392-232392

Anaren
What'll we think of next?™