

FEATURES

- Latch-up proof
- 4.5 pF off source capacitance
- 10 pF off drain capacitance
- 0.6 pC charge injection
- Low on resistance: 160 Ω typical
- ± 9 V to ± 22 V dual-supply operation
- 9 V to 40 V single-supply operation
- 48 V supply maximum ratings
- Fully specified at ± 15 V, ± 20 V, +12 V, and +36 V
- V_{DD} to V_{SS} analog signal range
- Human body model (HBM) ESD rating
 - 4 kV I/O port to supplies
 - 1 kV I/O port to I/O port
 - 4 kV all other pins

APPLICATIONS

- Automatic test equipment
- Data acquisition
- Instrumentation
- Avionics
- Audio and video switching
- Communication systems

GENERAL DESCRIPTION

The [ADG5233](#) and [ADG5234](#) are monolithic industrial CMOS analog switches comprising three independently selectable single-pole, double throw (SPDT) switches and four independently selectable SPDT switches, respectively.

All channels exhibit break-before-make switching action that prevents momentary shorting when switching channels. An \overline{EN} input on the [ADG5233](#) (LFCSP and TSSOP packages) is used to enable or disable the device. When disabled, all channels are switched off.

The ultralow capacitance and charge injection of these switches make them ideal solutions for data acquisition and sample-and-hold applications, where low glitch and fast settling are required. Fast switching speed coupled with high signal bandwidth make these devices suitable for video signal switching.

Rev. 0

Information furnished by Analog Devices is believed to be accurate and reliable. However, no responsibility is assumed by Analog Devices for its use, nor for any infringements of patents or other rights of third parties that may result from its use. Specifications subject to change without notice. No license is granted by implication or otherwise under any patent or patent rights of Analog Devices. Trademarks and registered trademarks are the property of their respective owners.

FUNCTIONAL BLOCK DIAGRAMS

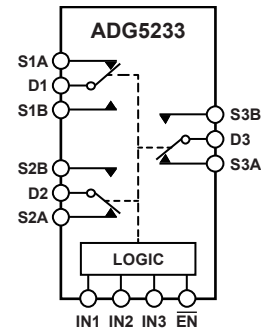

SWITCHES SHOWN FOR
A 1 INPUT LOGIC.

Figure 1. [ADG5233](#) TSSOP and LFCSP_VQ

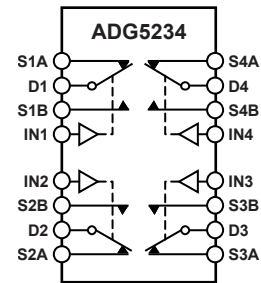

SWITCHES SHOWN FOR
A 1 INPUT LOGIC.

Figure 2. [ADG5234](#) TSSOP

PRODUCT HIGHLIGHTS

1. Trench Isolation Guards Against Latch-Up.
A dielectric trench separates the P and N channel transistors thereby preventing latch-up even under severe overvoltage conditions.
2. Ultralow Capacitance and -0.6 pC Charge Injection.
3. Dual-Supply Operation.
For applications where the analog signal is bipolar, the [ADG5233/ADG5234](#) can be operated from dual supplies up to ± 22 V.
4. Single-Supply Operation.
For applications where the analog signal is unipolar, the [ADG5233/ADG5234](#) can be operated from a single-rail power supply up to 40 V.
5. 3 V Logic-Compatible Digital Inputs.
 $V_{INH} = 2.0$ V, $V_{INL} = 0.8$ V.
6. No V_L Logic Power Supply Required.

TABLE OF CONTENTS

Features	1	Continuous Current per Channel, Sx or Dx.....	8
Applications.....	1	Absolute Maximum Ratings	9
Functional Block Diagrams.....	1	ESD Caution.....	9
General Description	1	Pin Configurations and Function Descriptions	10
Product Highlights	1	Typical Performance Characteristics	12
Revision History	2	Test Circuits.....	16
Specifications.....	3	Terminology	18
±15 V Dual Supply	3	Trench Isolation	19
±20 V Dual Supply	4	Applications Information	20
12 V Single Supply.....	5	Outline Dimensions	21
36 V Single Supply.....	6	Ordering Guide	21

REVISION HISTORY

7/11—Revision 0: Initial Version

SPECIFICATIONS

±15 V DUAL SUPPLY

$V_{DD} = +15\text{ V} \pm 10\%$, $V_{SS} = -15\text{ V} \pm 10\%$, $GND = 0\text{ V}$, unless otherwise noted.

Table 1.

Parameter	25°C	-40°C to +85°C	-40°C to +125°C	Unit	Test Conditions/Comments
ANALOG SWITCH					
Analog Signal Range			V_{DD} to V_{SS}	V	
On Resistance, R_{ON}	160			Ω typ	$V_S = \pm 10\text{ V}$, $I_S = -1\text{ mA}$; see Figure 26
	200	250	280	Ω max	$V_{DD} = +13.5\text{ V}$, $V_{SS} = -13.5\text{ V}$
On-Resistance Match Between Channels, ΔR_{ON}	3.5			Ω typ	$V_S = \pm 10\text{ V}$, $I_S = -1\text{ mA}$
	8	9	10	Ω max	
On-Resistance Flatness, $R_{FLAT(ON)}$	38			Ω typ	$V_S = \pm 10\text{ V}$, $I_S = -1\text{ mA}$
	50	65	70	Ω max	
LEAKAGE CURRENTS					
Source Off Leakage, I_S (Off)	± 0.02			nA typ	$V_{DD} = +16.5\text{ V}$, $V_{SS} = -16.5\text{ V}$
	± 0.1	± 0.2	± 0.4	nA max	$V_S = \pm 10\text{ V}$, $V_D = \mp 10\text{ V}$; see Figure 28
Drain Off Leakage, I_D (Off)	± 0.02			nA typ	$V_S = \pm 10\text{ V}$, $V_D = \mp 10\text{ V}$; see Figure 28
	± 0.1	± 0.2	± 0.4	nA max	
Channel On Leakage, I_D (On), I_S (On)	± 0.08			nA typ	$V_S = V_D = \pm 10\text{ V}$; see Figure 25
	± 0.2	± 0.3	± 0.9	nA max	
DIGITAL INPUTS					
Input High Voltage, V_{INH}			2.0	V min	
Input Low Voltage, V_{INL}			0.8	V max	
Input Current, I_{INL} or I_{INH}	0.002			μA typ	$V_{IN} = V_{GND}$ or V_{DD}
			± 0.1	μA max	
Digital Input Capacitance, C_{IN}	3			pF typ	
DYNAMIC CHARACTERISTICS¹					
Transition Time, $t_{TRANSITION}$	170			ns typ	$R_L = 300\ \Omega$, $C_L = 35\text{ pF}$
	210	250	280	ns max	$V_S = 10\text{ V}$; see Figure 31
$t_{ON}(\overline{EN})$	175			ns typ	$R_L = 300\ \Omega$, $C_L = 35\text{ pF}$
	215	255	290	ns max	$V_S = 10\text{ V}$; see Figure 33
$t_{OFF}(\overline{EN})$	80			ns typ	$R_L = 300\ \Omega$, $C_L = 35\text{ pF}$
	100	115	125	ns max	$V_S = 10\text{ V}$; see Figure 33
Break-Before-Make Time Delay, t_D	60			ns typ	$R_L = 300\ \Omega$, $C_L = 35\text{ pF}$
			30	ns min	$V_{S1} = V_{S2} = 10\text{ V}$; see Figure 32
Charge Injection, Q_{INJ}	-0.6			pC typ	$V_S = 0\text{ V}$, $R_S = 0\ \Omega$, $C_L = 1\text{ nF}$; see Figure 34
Off Isolation	-75			dB typ	$R_L = 50\ \Omega$, $C_L = 5\text{ pF}$, $f = 1\text{ MHz}$; see Figure 29
Channel-to-Channel Crosstalk	-80			dB typ	$R_L = 50\ \Omega$, $C_L = 5\text{ pF}$, $f = 1\text{ MHz}$; see Figure 27
-3 dB Bandwidth	205			MHz typ	$R_L = 50\ \Omega$, $C_L = 5\text{ pF}$; see Figure 30
Insertion Loss	-6.3			dB typ	$R_L = 50\ \Omega$, $C_L = 5\text{ pF}$, $f = 1\text{ MHz}$; see Figure 30
C_S (Off)	4.5			pF typ	$V_S = 0\text{ V}$, $f = 1\text{ MHz}$
C_D (Off)	10			pF typ	$V_S = 0\text{ V}$, $f = 1\text{ MHz}$
C_D (On), C_S (On)	15			pF typ	$V_S = 0\text{ V}$, $f = 1\text{ MHz}$

ADG5233/ADG5234

Parameter	25°C	-40°C to +85°C	-40°C to +125°C	Unit	Test Conditions/Comments
POWER REQUIREMENTS					
I_{DD}	45			$\mu\text{A typ}$	$V_{DD} = +16.5\text{ V}$, $V_{SS} = -16.5\text{ V}$ Digital inputs = 0 V or V_{DD}
	55		70	$\mu\text{A max}$	
I_{SS}	0.001			$\mu\text{A typ}$	Digital inputs = 0 V or V_{DD}
			1	$\mu\text{A max}$	
V_{DD}/V_{SS}			$\pm 9/\pm 22$	V min/V max	GND = 0 V

¹ Guaranteed by design; not subject to production test.

±20 V DUAL SUPPLY

$V_{DD} = +20\text{ V} \pm 10\%$, $V_{SS} = -20\text{ V} \pm 10\%$, GND = 0 V, unless otherwise noted.

Table 2.

Parameter	25°C	-40°C to +85°C	-40°C to +125°C	Unit	Test Conditions/Comments
ANALOG SWITCH					
Analog Signal Range			V_{DD} to V_{SS}	V	
On Resistance, R_{ON}	140			Ω typ	$V_S = \pm 15\text{ V}$, $I_S = -1\text{ mA}$; see Figure 26
	160	200	230	Ω max	$V_{DD} = +18\text{ V}$, $V_{SS} = -18\text{ V}$
On-Resistance Match Between Channels, ΔR_{ON}	3.5			Ω typ	$V_S = \pm 15\text{ V}$, $I_S = -1\text{ mA}$
	8	9	10	Ω max	
On-Resistance Flatness, $R_{FLAT(ON)}$	33			Ω typ	$V_S = \pm 15\text{ V}$, $I_S = -1\text{ mA}$
	45	55	60	Ω max	
LEAKAGE CURRENTS					
Source Off Leakage, I_S (Off)	± 0.02			nA typ	$V_{DD} = +22\text{ V}$, $V_{SS} = -22\text{ V}$ $V_S = \pm 15\text{ V}$, $V_D = \mp 15\text{ V}$; see Figure 28
	± 0.1	± 0.2	± 0.4	nA max	
Drain Off Leakage, I_D (Off)	± 0.02			nA typ	$V_S = \pm 15\text{ V}$, $V_D = \mp 15\text{ V}$; see Figure 28
	± 0.1	± 0.2	± 0.4	nA max	
Channel On Leakage, I_D (On), I_S (On)	± 0.08			nA typ	$V_S = V_D = \pm 15\text{ V}$; see Figure 25
	± 0.2	± 0.3	± 0.9	nA max	
DIGITAL INPUTS					
Input High Voltage, V_{INH}			2.0	V min	
Input Low Voltage, V_{INL}			0.8	V max	
Input Current, I_{INL} or I_{INH}	0.002			$\mu\text{A typ}$	$V_{IN} = V_{GND}$ or V_{DD}
			± 0.1	$\mu\text{A max}$	
Digital Input Capacitance, C_{IN}	3			pF typ	
DYNAMIC CHARACTERISTICS¹					
Transition Time, $t_{TRANSITION}$	170			ns typ	$R_L = 300\ \Omega$, $C_L = 35\text{ pF}$
	200	235	260	ns max	$V_S = 10\text{ V}$; see Figure 31
$t_{ON}(\overline{EN})$	165			ns typ	$R_L = 300\ \Omega$, $C_L = 35\text{ pF}$
	200	240	265	ns max	$V_S = 10\text{ V}$; see Figure 33
$t_{OFF}(\overline{EN})$	80			ns typ	$R_L = 300\ \Omega$, $C_L = 35\text{ pF}$
	95	105	115	ns max	$V_S = 10\text{ V}$; see Figure 33
Break-Before-Make Time Delay, t_D	50			ns typ	$R_L = 300\ \Omega$, $C_L = 35\text{ pF}$
			30	ns min	$V_{S1} = V_{S2} = 10\text{ V}$; see Figure 32
Charge Injection, Q_{INJ}	0			pC typ	$V_S = 0\text{ V}$, $R_S = 0\ \Omega$, $C_L = 1\text{ nF}$; see Figure 34
Off Isolation	-75			dB typ	$R_L = 50\ \Omega$, $C_L = 5\text{ pF}$, $f = 1\text{ MHz}$; see Figure 29
Channel-to-Channel Crosstalk	-80			dB typ	$R_L = 50\ \Omega$, $C_L = 5\text{ pF}$, $f = 1\text{ MHz}$; see Figure 27
-3 dB Bandwidth	210			MHz typ	$R_L = 50\ \Omega$, $C_L = 5\text{ pF}$; see Figure 30
Insertion Loss	-5.5			dB typ	$R_L = 50\ \Omega$, $C_L = 5\text{ pF}$, $f = 1\text{ MHz}$; see Figure 30

Parameter	25°C	-40°C to +85°C	-40°C to +125°C	Unit	Test Conditions/Comments
C _S (Off)	4.5			pF typ	V _S = 0 V, f = 1 MHz
C _D (Off)	10			pF typ	V _S = 0 V, f = 1 MHz
C _D (On), C _S (On)	15			pF typ	V _S = 0 V, f = 1 MHz
POWER REQUIREMENTS					
I _{DD}	50			μA typ	V _{DD} = +22 V, V _{SS} = -22 V
	70		110	μA max	Digital inputs = 0 V or V _{DD}
I _{SS}	0.001			μA typ	Digital inputs = 0 V or V _{DD}
			1	μA max	
V _{DD} /V _{SS}			±9/±22	V min/V max	GND = 0 V

¹ Guaranteed by design; not subject to production test.

12 V SINGLE SUPPLY

V_{DD} = 12 V ± 10%, V_{SS} = 0 V, GND = 0 V, unless otherwise noted.

Table 3.

Parameter	25°C	-40°C to +85°C	-40°C to +125°C	Unit	Test Conditions/Comments
ANALOG SWITCH					
Analog Signal Range			0 V to V _{DD}	V	
On Resistance, R _{ON}	360			Ω typ	V _S = 0 V to 10 V, I _S = -1 mA; see Figure 26
On-Resistance Match Between Channels, ΔR _{ON}	500	610	700	Ω max	V _{DD} = 10.8 V, V _{SS} = 0 V
	5.5			Ω typ	V _S = 0 V to 10 V, I _S = -1 mA
On-Resistance Flatness, R _{FLAT(ON)}	20	21	22	Ω max	
	170			Ω typ	V _S = 0 V to 10 V, I _S = -1 mA
	280	335	370	Ω max	
LEAKAGE CURRENTS					
Source Off Leakage, I _S (Off)	±0.02			nA typ	V _{DD} = 13.2 V, V _{SS} = 0 V
Drain Off Leakage, I _D (Off)	±0.1	±0.2	±0.4	nA max	V _S = 1 V/10 V, V _D = 10 V/1 V; see Figure 28
	±0.02			nA typ	V _S = 1 V/10 V, V _D = 10 V/1 V; see Figure 28
Channel On Leakage, I _D (On), I _S (On)	±0.1	±0.2	±0.4	nA max	
	±0.08			nA typ	V _S = V _D = 1 V/10 V; see Figure 25
	±0.2	±0.3	±0.9	nA max	
DIGITAL INPUTS					
Input High Voltage, V _{INH}			2.0	V min	
Input Low Voltage, V _{INL}			0.8	V max	
Input Current, I _{INL} or I _{INH}	0.002			μA typ	V _{IN} = V _{GND} or V _{DD}
			±0.1	μA max	
Digital Input Capacitance, C _{IN}	3			pF typ	
DYNAMIC CHARACTERISTICS¹					
Transition Time, t _{TRANSITION}	235			ns typ	R _L = 300 Ω, C _L = 35 pF
	295	365	410	ns max	V _S = 8 V; see Figure 31
t _{ON} ($\overline{\text{EN}}$)	240			ns typ	R _L = 300 Ω, C _L = 35 pF
	305	380	430	ns max	V _S = 8 V; see Figure 33
t _{OFF} ($\overline{\text{EN}}$)	70			ns typ	R _L = 300 Ω, C _L = 35 pF
	90	105	115	ns max	V _S = 8 V; see Figure 33
Break-Before-Make Time Delay, t _D	125			ns typ	R _L = 300 Ω, C _L = 35 pF
			65	ns min	V _{S1} = V _{S2} = 8 V; see Figure 32
Charge Injection, Q _{INJ}	0			pC typ	V _S = 6 V, R _S = 0 Ω, C _L = 1 nF; see Figure 34

ADG5233/ADG5234

Parameter	25°C	-40°C to +85°C	-40°C to +125°C	Unit	Test Conditions/Comments
Off Isolation	-75			dB typ	$R_L = 50\ \Omega$, $C_L = 5\ \text{pF}$, $f = 1\ \text{MHz}$; see Figure 29
Channel-to-Channel Crosstalk	-80			dB typ	$R_L = 50\ \Omega$, $C_L = 5\ \text{pF}$, $f = 1\ \text{MHz}$; see Figure 27
-3 dB Bandwidth	172			MHz typ	$R_L = 50\ \Omega$, $C_L = 5\ \text{pF}$; see Figure 30
Insertion Loss	-8.7			dB typ	$R_L = 50\ \Omega$, $C_L = 5\ \text{pF}$, $f = 1\ \text{MHz}$; see Figure 30
C_S (Off)	5			pF typ	$V_S = 6\ \text{V}$, $f = 1\ \text{MHz}$
C_D (Off)	11			pF typ	$V_S = 6\ \text{V}$, $f = 1\ \text{MHz}$
C_D (On), C_S (On)	16			pF typ	$V_S = 6\ \text{V}$, $f = 1\ \text{MHz}$
POWER REQUIREMENTS					
I_{DD}	40			μA typ	$V_{DD} = 13.2\ \text{V}$
	50		65	μA max	Digital inputs = 0 V or V_{DD}
V_{DD}			9/40	V min/V max	$\text{GND} = 0\ \text{V}$, $V_{SS} = 0\ \text{V}$

¹ Guaranteed by design; not subject to production test.

36 V SINGLE SUPPLY

$V_{DD} = 36\ \text{V} \pm 10\%$, $V_{SS} = 0\ \text{V}$, $\text{GND} = 0\ \text{V}$, unless otherwise noted.

Table 4.

Parameter	25°C	-40°C to +85°C	-40°C to +125°C	Unit	Test Conditions/Comments
ANALOG SWITCH					
Analog Signal Range			0 V to V_{DD}	V	
On Resistance, R_{ON}	140			Ω typ	$V_S = 0\ \text{V}$ to 30 V, $I_S = -1\ \text{mA}$; see Figure 26
	170	215	245	Ω max	$V_{DD} = 32.4\ \text{V}$, $V_{SS} = 0\ \text{V}$
On-Resistance Match Between Channels, ΔR_{ON}	3.5			Ω typ	$V_S = 0\ \text{V}$ to 30 V, $I_S = -1\ \text{mA}$
	8	9	10	Ω max	
On-Resistance Flatness, $R_{FLAT(ON)}$	35			Ω typ	$V_S = 0\ \text{V}$ to 30 V, $I_S = -1\ \text{mA}$
	50	60	65	Ω max	
LEAKAGE CURRENTS					
Source Off Leakage, I_S (Off)	± 0.02			nA typ	$V_{DD} = 39.6\ \text{V}$, $V_{SS} = 0\ \text{V}$
	± 0.1	± 0.2	± 0.4	nA max	$V_S = 1\ \text{V}/30\ \text{V}$, $V_D = 30\ \text{V}/1\ \text{V}$; see Figure 28
Drain Off Leakage, I_D (Off)	± 0.02			nA typ	$V_S = 1\ \text{V}/30\ \text{V}$, $V_D = 30\ \text{V}/1\ \text{V}$; see Figure 28
	± 0.1	± 0.2	± 0.4	nA max	
Channel On Leakage, I_D (On), I_S (On)	± 0.08			nA typ	$V_S = V_D = 1\ \text{V}/30\ \text{V}$; see Figure 25
	± 0.2	± 0.3	± 0.9	nA max	
DIGITAL INPUTS					
Input High Voltage, V_{INH}			2.0	V min	
Input Low Voltage, V_{INL}			0.8	V max	
Input Current, I_{INL} or I_{INH}	0.002			μA typ	$V_{IN} = V_{GND}$ or V_{DD}
			± 0.1	μA max	
Digital Input Capacitance, C_{IN}	3			pF typ	
DYNAMIC CHARACTERISTICS¹					
Transition Time, $t_{TRANSITION}$	205			ns typ	$R_L = 300\ \Omega$, $C_L = 35\ \text{pF}$
	255	275	290	ns max	$V_S = 18\ \text{V}$; see Figure 31
$t_{ON}(\overline{\text{EN}})$	200			ns typ	$R_L = 300\ \Omega$, $C_L = 35\ \text{pF}$
	240	265	290	ns max	$V_S = 18\ \text{V}$; see Figure 33
$t_{OFF}(\overline{\text{EN}})$	85			ns typ	$R_L = 300\ \Omega$, $C_L = 35\ \text{pF}$
	115	115	115	ns max	$V_S = 18\ \text{V}$; see Figure 33

Parameter	25°C	-40°C to +85°C	-40°C to +125°C	Unit	Test Conditions/Comments
Break-Before-Make Time Delay, t_D	65		35	ns typ	$R_L = 300 \Omega$, $C_L = 35 \text{ pF}$
Charge Injection, Q_{INJ}	-0.6			ns min pC typ	$V_{S1} = V_{S2} = 18 \text{ V}$; see Figure 32 $V_S = 18 \text{ V}$, $R_S = 0 \Omega$, $C_L = 1 \text{ nF}$; see Figure 34
Off Isolation	-75			dB typ	$R_L = 50 \Omega$, $C_L = 5 \text{ pF}$, $f = 1 \text{ MHz}$; see Figure 29
Channel-to-Channel Crosstalk	-80			dB typ	$R_L = 50 \Omega$, $C_L = 5 \text{ pF}$, $f = 1 \text{ MHz}$; see Figure 27
-3 dB Bandwidth	190			MHz typ	$R_L = 50 \Omega$, $C_L = 5 \text{ pF}$; see Figure 30
Insertion Loss	-5.9			dB typ	$R_L = 50 \Omega$, $C_L = 5 \text{ pF}$, $f = 1 \text{ MHz}$; see Figure 30
C_S (Off)	4.5			pF typ	$V_S = 18 \text{ V}$, $f = 1 \text{ MHz}$
C_D (Off)	10			pF typ	$V_S = 18 \text{ V}$, $f = 1 \text{ MHz}$
C_D (On), C_S (On)	15			pF typ	$V_S = 18 \text{ V}$, $f = 1 \text{ MHz}$
POWER REQUIREMENTS					$V_{DD} = 39.6 \text{ V}$
I_{DD}	80			$\mu\text{A typ}$	Digital inputs = 0 V or V_{DD}
	100		130	$\mu\text{A max}$	
V_{DD}			9/40	V min/V max	GND = 0 V, $V_{SS} = 0 \text{ V}$

¹ Guaranteed by design; not subject to production test.

ADG5233/ADG5234

CONTINUOUS CURRENT PER CHANNEL, Sx OR Dx

Table 5. ADG5233

Parameter	25°C	85°C	125°C	Unit
CONTINUOUS CURRENT, Sx OR Dx				
$V_{DD} = +15\text{ V}, V_{SS} = -15\text{ V}$				
TSSOP ($\theta_{JA} = 112.6^\circ\text{C/W}$)	24	16	11	mA maximum
LFCSP ($\theta_{JA} = 30.4^\circ\text{C/W}$)	42	26.5	15	mA maximum
$V_{DD} = +20\text{ V}, V_{SS} = -20\text{ V}$				
TSSOP ($\theta_{JA} = 112.6^\circ\text{C/W}$)	26	17	11	mA maximum
LFCSP ($\theta_{JA} = 30.4^\circ\text{C/W}$)	46	28	15	mA maximum
$V_{DD} = 12\text{ V}, V_{SS} = 0\text{ V}$				
TSSOP ($\theta_{JA} = 112.6^\circ\text{C/W}$)	17	12	7.7	mA maximum
LFCSP ($\theta_{JA} = 30.4^\circ\text{C/W}$)	24	17	11	mA maximum
$V_{DD} = 36\text{ V}, V_{SS} = 0\text{ V}$				
TSSOP ($\theta_{JA} = 112.6^\circ\text{C/W}$)	25	17	11	mA maximum
LFCSP ($\theta_{JA} = 30.4^\circ\text{C/W}$)	45	28	15	mA maximum

Table 6. ADG5234

Parameter	25°C	85°C	125°C	Unit
CONTINUOUS CURRENT, Sx OR Dx				
$V_{DD} = +15\text{ V}, V_{SS} = -15\text{ V}$				
TSSOP ($\theta_{JA} = 112.6^\circ\text{C/W}$)	21	15	10	mA maximum
$V_{DD} = +20\text{ V}, V_{SS} = -20\text{ V}$				
TSSOP ($\theta_{JA} = 112.6^\circ\text{C/W}$)	22	15	10	mA maximum
$V_{DD} = 12\text{ V}, V_{SS} = 0\text{ V}$				
TSSOP ($\theta_{JA} = 112.6^\circ\text{C/W}$)	15	11	7	mA maximum
$V_{DD} = 36\text{ V}, V_{SS} = 0\text{ V}$				
TSSOP ($\theta_{JA} = 112.6^\circ\text{C/W}$)	22	15	10	mA maximum

ABSOLUTE MAXIMUM RATINGS

$T_A = 25^\circ\text{C}$, unless otherwise noted.

Table 7.

Parameter	Rating
V_{DD} to V_{SS}	48 V
V_{DD} to GND	-0.3 V to +48 V
V_{SS} to GND	+0.3 V to -48 V
Analog Inputs ¹	$V_{SS} - 0.3\text{ V}$ to $V_{DD} + 0.3\text{ V}$ or 30 mA, whichever occurs first
Digital Inputs ¹	$V_{SS} - 0.3\text{ V}$ to $V_{DD} + 0.3\text{ V}$ or 30 mA, whichever occurs first
Peak Current, Sx or Dx Pins ADG5233	76 mA (pulsed at 1 ms, 10% duty cycle maximum)
ADG5234	67 mA (pulsed at 1 ms, 10% duty cycle maximum)
Continuous Current, Sx or Dx ²	Data + 15%
Temperature Range	
Operating	-40°C to +125°C
Storage	-65°C to +150°C
Junction Temperature	150°C
Thermal Impedance, θ_{JA}	
16-Lead TSSOP (4-Layer Board)	112.6°C/W
20-Lead TSSOP (4-Layer Board)	143°C/W
16-Lead LFCSP (4-Layer Board)	30.4°C/W
Reflow Soldering Peak Temperature, Pb Free	260(+0/-5)°C
Human Body Model (HBM) ESD	
I/O Port to Supplies	4 kV
I/O Port to I/O Port	1 kV
All Other Pins	4 kV

¹ Overvoltages at the INx, Sx, and Dx pins are clamped by internal diodes. Limit current to the maximum ratings given.

² See Table 5 and Table 6.

Stresses above those listed under Absolute Maximum Ratings may cause permanent damage to the device. This is a stress rating only; functional operation of the device at these or any other conditions above those indicated in the operational section of this specification is not implied. Exposure to absolute maximum rating conditions for extended periods may affect device reliability.

Only one absolute maximum rating can be applied at any one time.

ESD CAUTION



ESD (electrostatic discharge) sensitive device.

Charged devices and circuit boards can discharge without detection. Although this product features patented or proprietary protection circuitry, damage may occur on devices subjected to high energy ESD. Therefore, proper ESD precautions should be taken to avoid performance degradation or loss of functionality.

ADG5233/ADG5234

PIN CONFIGURATIONS AND FUNCTION DESCRIPTIONS

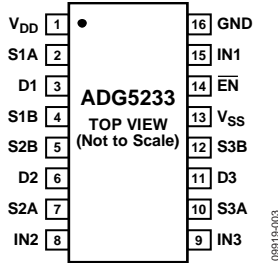
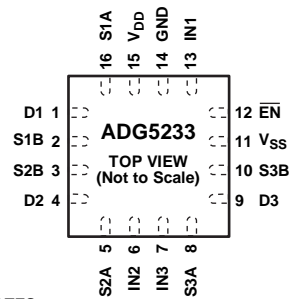

Figure 3. ADG5233 TSSOP Pin Configuration



NOTES
1. EXPOSED PAD TIED TO SUBSTRATE, V_{SS}.

Figure 4. ADG5233 LFCSP_VQ Pin Configuration

Table 8. ADG5233 Pin Function Descriptions

Pin No.		Mnemonic	Description
TSSOP	LFCSP_VQ		
1	15	V _{DD}	Most Positive Power Supply Potential.
2	16	S1A	Source Terminal 1A. This pin can be an input or an output.
3	1	D1	Drain Terminal 1. This pin can be an input or an output.
4	2	S1B	Source Terminal 1B. This pin can be an input or an output.
5	3	S2B	Source Terminal 2B. This pin can be an input or an output.
6	4	D2	Drain Terminal 2. This pin can be an input or an output.
7	5	S2A	Source Terminal 2A. This pin can be an input or an output.
8	6	IN2	Logic Control Input 2.
9	7	IN3	Logic Control Input 3.
10	8	S3A	Source Terminal 3A. This pin can be an input or an output.
11	9	D3	Drain Terminal 3. This pin can be an input or an output.
12	10	S3B	Source Terminal 3B. This pin can be an input or an output.
13	11	V _{SS}	Most Negative Power Supply Potential. In single-supply applications, this pin can be connected to ground.
14	12	$\overline{\text{EN}}$	Active Low Digital Input. When high, the device is disabled and all switches are off. When low, IN _x logic inputs determine the on switches.
15	13	IN1	Logic Control Input 1.
16	14	GND	Ground (0 V) Reference.
	EP	Exposed Pad	The exposed pad is connected internally. For increased reliability of the solder joints and maximum thermal capability, it is recommended that the pad be soldered to the substrate, V _{SS} .

Table 9. ADG5233 Truth Table

EN	IN _x	S _x A	S _x B
1	X ¹	Off	Off
0	0	Off	On
0	1	On	Off

¹ X is don't care.

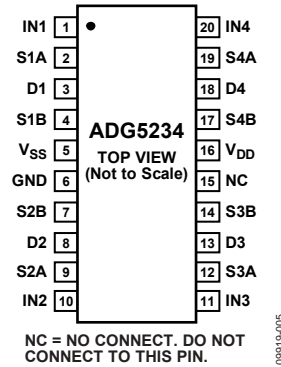

Figure 5. ADG5234 TSSOP Pin Configuration

Table 10. ADG5234 Pin Function Descriptions

Pin No.	Mnemonic	Description
1	IN1	Logic Control Input 1.
2	S1A	Source Terminal 1A. This pin can be an input or an output.
3	D1	Drain Terminal 1. This pin can be an input or an output.
4	S1B	Source Terminal 1B. This pin can be an input or an output.
5	V _{SS}	Most Negative Power Supply Potential. In single-supply applications, this pin can be connected to ground.
6	GND	Ground (0 V) Reference.
7	S2B	Source Terminal 2B. This pin can be an input or an output.
8	D2	Drain Terminal 2. This pin can be an input or an output.
9	S2A	Source Terminal 2A. This pin can be an input or an output.
10	IN2	Logic Control Input 2.
11	IN3	Logic Control Input 3.
12	S3A	Source Terminal 3A. This pin can be an input or an output.
13	D3	Drain Terminal 3. This pin can be an input or an output.
14	S3B	Source Terminal 3B. This pin can be an input or an output.
15	NC	No Connect. This pin is open.
16	V _{DD}	Most Positive Power Supply Potential.
17	S4B	Source Terminal 4B. This pin can be an input or an output.
18	D4	Drain Terminal 4. This pin can be an input or an output.
19	S4A	Source Terminal 4A. This pin can be an input or an output.
20	IN4	Logic Control Input 4.

Table 11. ADG5234 Truth Table

IN _x	S _x A	S _x B
0	Off	On
1	On	Off

TYPICAL PERFORMANCE CHARACTERISTICS

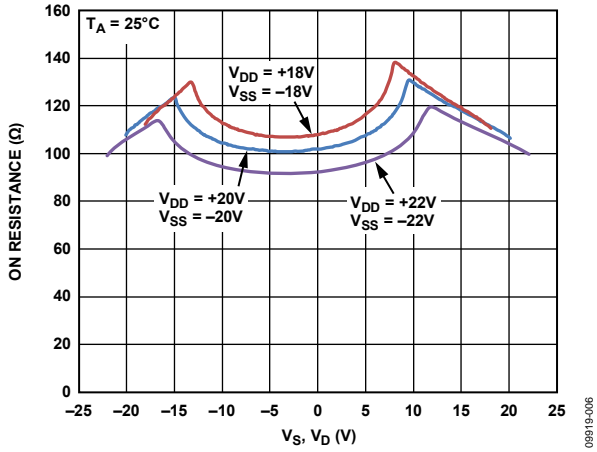

Figure 6. On Resistance as a Function of V_S, V_D (± 20 V Dual Supply)

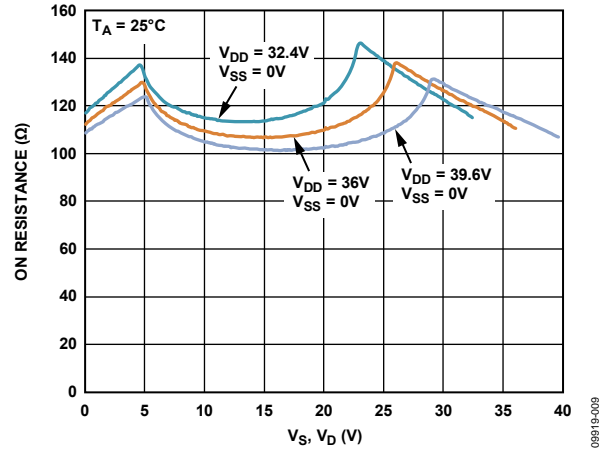

Figure 9. On Resistance as a Function of V_S, V_D (36 V Single Supply)

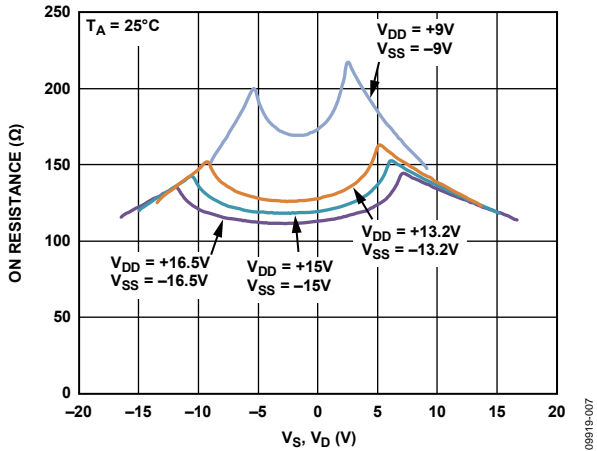

Figure 7. On Resistance as a Function of V_S, V_D (± 15 V Dual Supply)

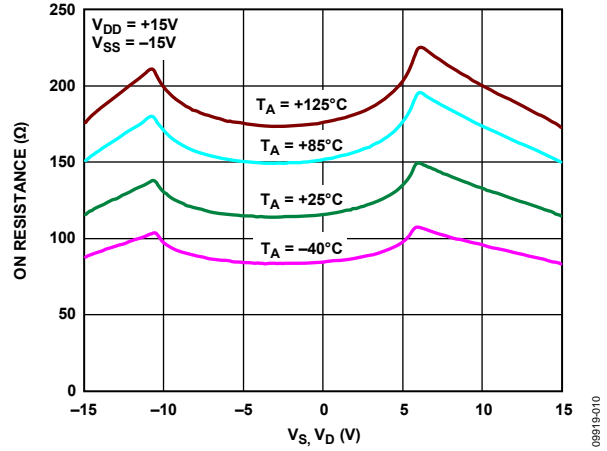

Figure 10. On Resistance as a Function of $V_S (V_D)$ for Different Temperatures, ± 15 V Dual Supply

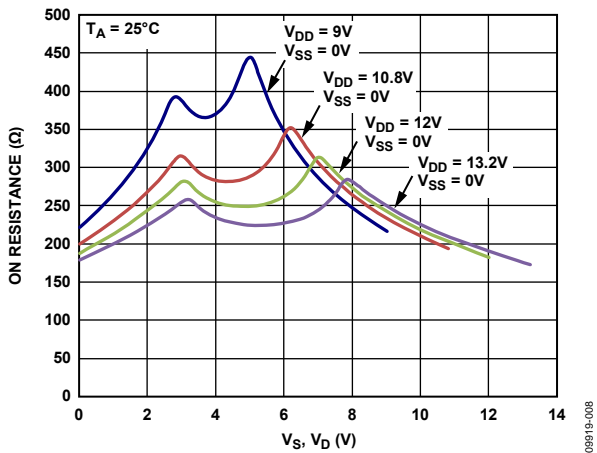

Figure 8. On Resistance as a Function of V_S, V_D (12 V Single Supply)

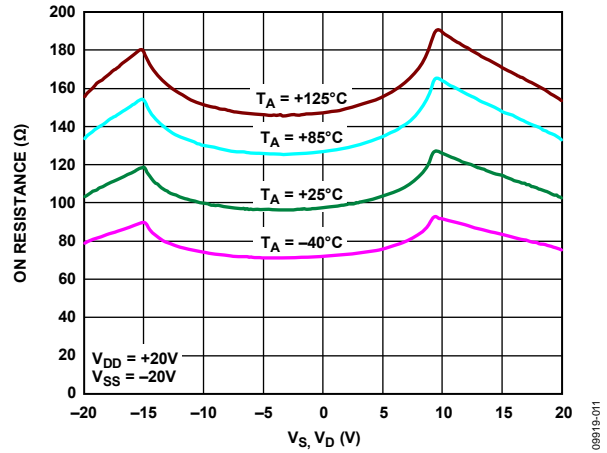

Figure 11. On Resistance as a Function of $V_S (V_D)$ for Different Temperatures, ± 20 V Dual Supply

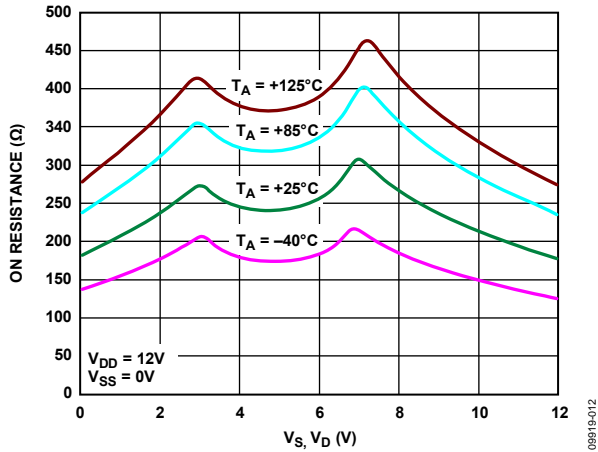

Figure 12. On Resistance as a Function of V_S (V_D) for Different Temperatures, 12 V Single Supply

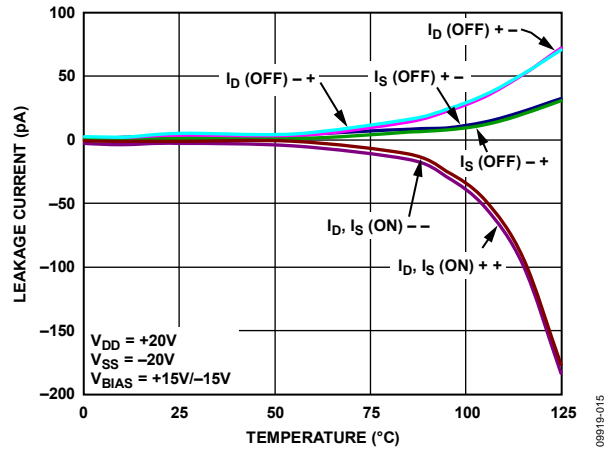

Figure 15. Leakage Currents as a Function of Temperature, ± 20 V Dual Supply

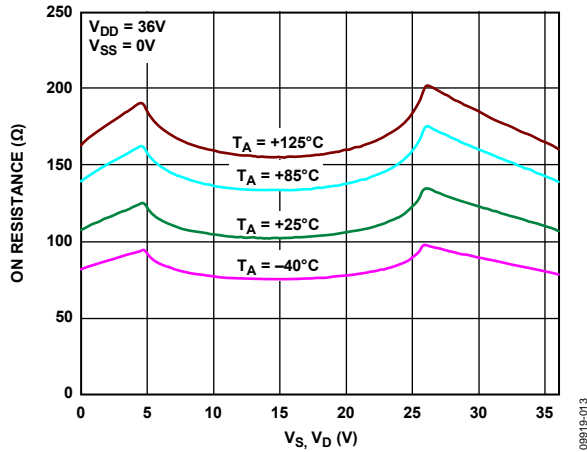

Figure 13. On Resistance as a Function of V_S (V_D) for Different Temperatures, 36 V Single Supply

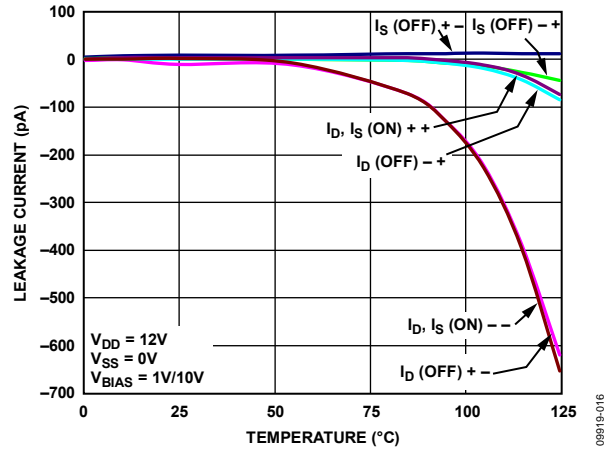

Figure 16. Leakage Currents as a Function of Temperature, 12 V Single Supply

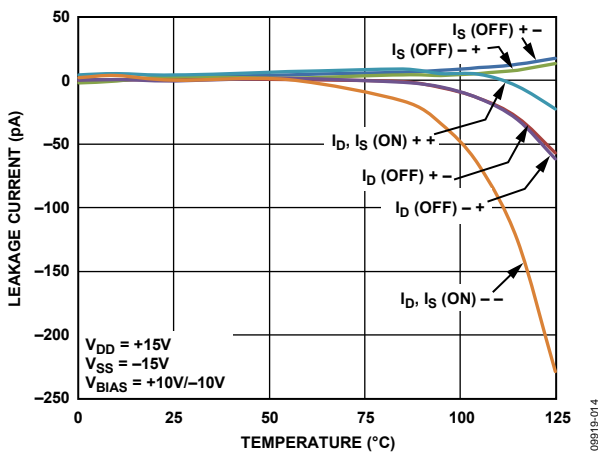

Figure 14. Leakage Currents as a Function of Temperature, ± 15 V Dual Supply

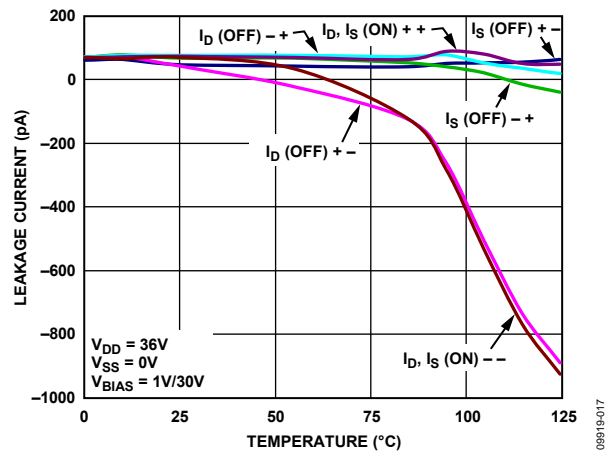

Figure 17. Leakage Currents as a Function of Temperature, 36 V Single Supply

ADG5233/ADG5234

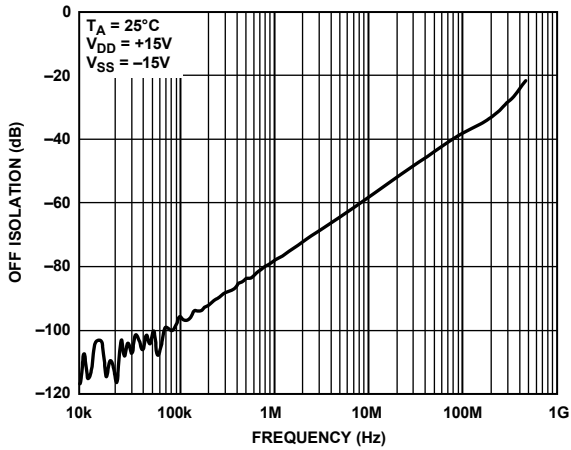

Figure 18. Off Isolation vs. Frequency, ±15 V Dual Supply

08919-018

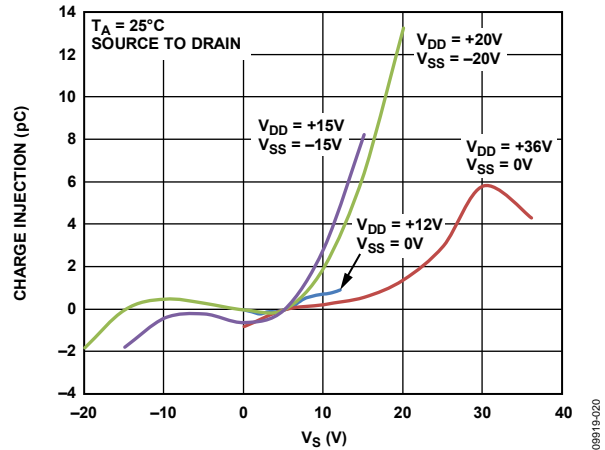

Figure 20. Charge Injection vs. Source Voltage, Source to Drain

08919-020

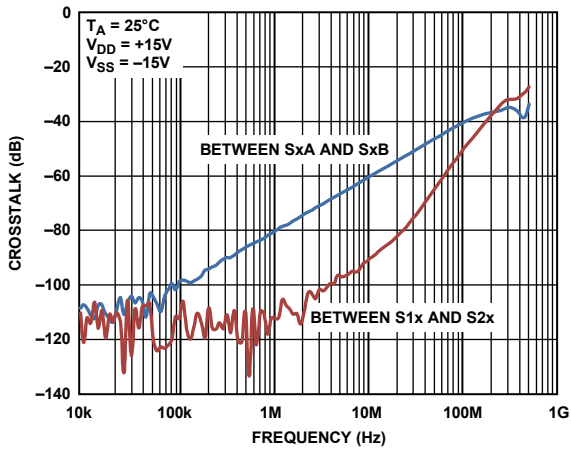

Figure 19. Crosstalk vs. Frequency, ±15 V Dual Supply

08919-019

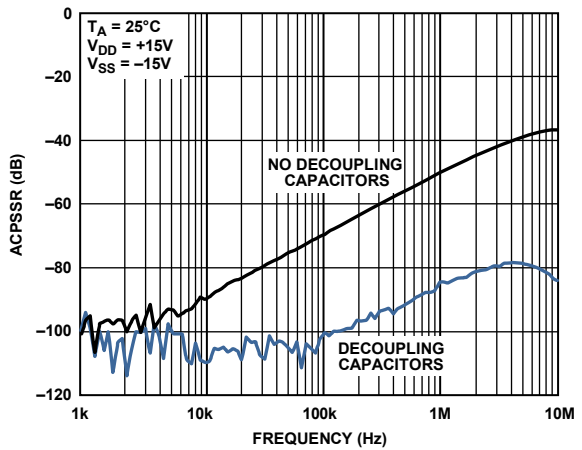

Figure 21. ACPSRR vs. Frequency, ±15 V Dual Supply

08919-021

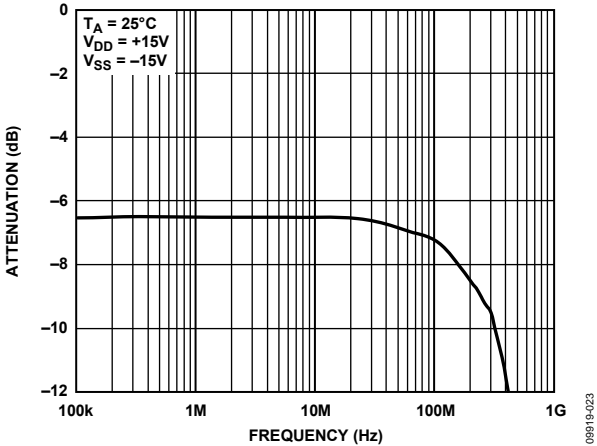

Figure 22. Bandwidth

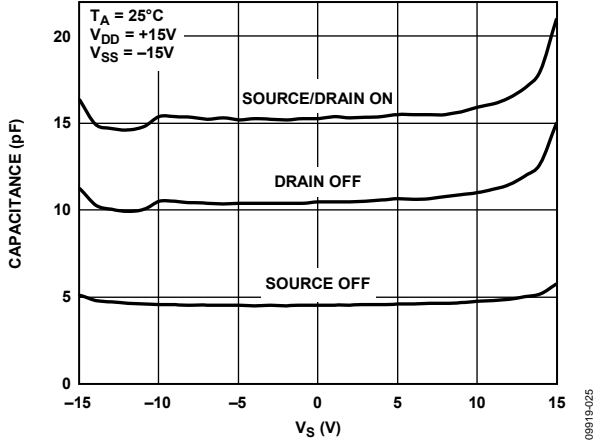

Figure 24. Capacitance vs. Source Voltage, ±15 V Dual Supply

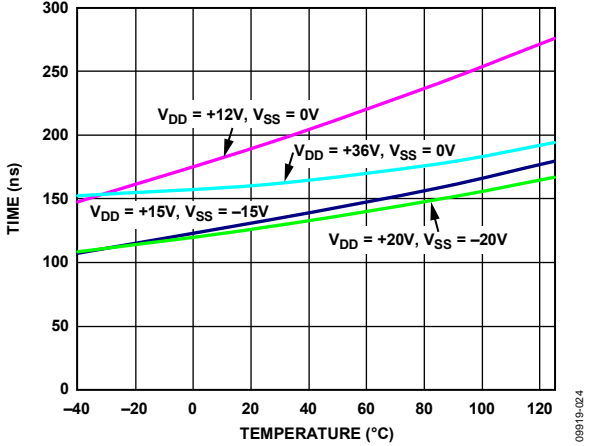

Figure 23. $t_{\text{TRANSITION}}$ Times vs. Temperature

09919-023

09919-025

09919-024

TEST CIRCUITS

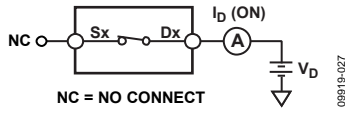

Figure 25. On Leakage

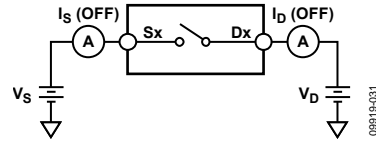

Figure 28. Off Leakage

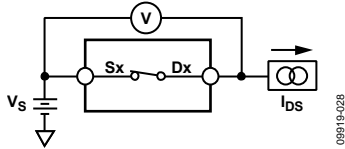

Figure 26. On Resistance

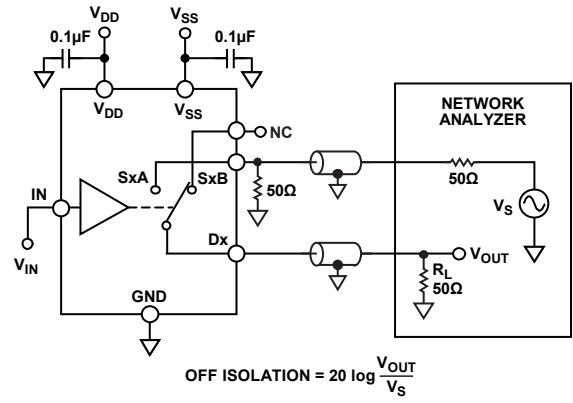

Figure 29. Off Isolation

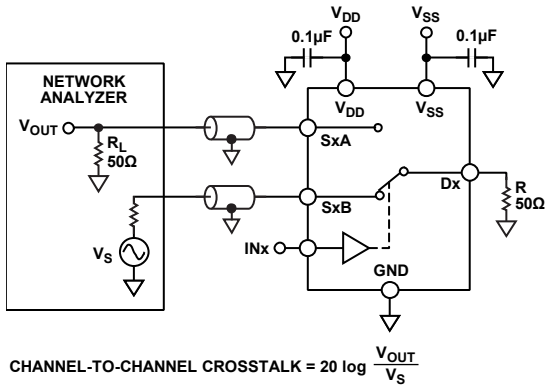

Figure 27. Channel-to-Channel Crosstalk

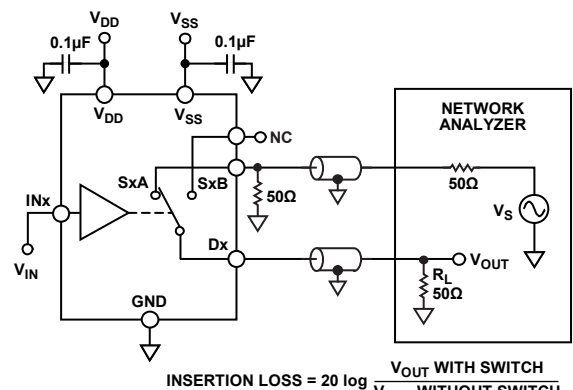

Figure 30. Bandwidth

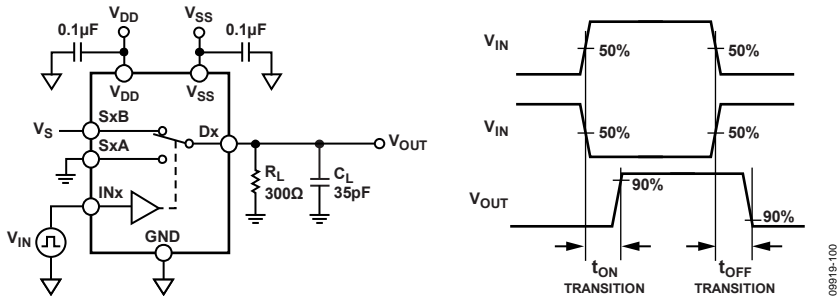

Figure 31. Switching Timing

09919-100

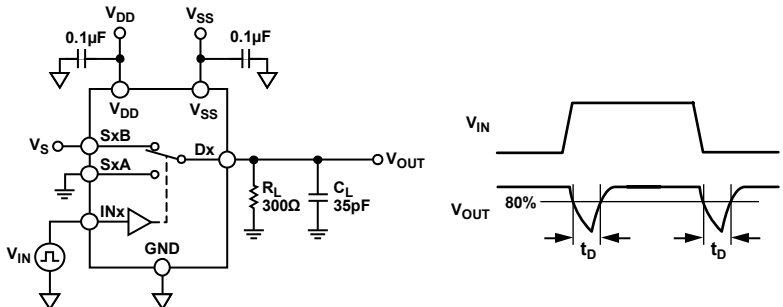

Figure 32. Break-Before-Make Delay, t_D

09919-035

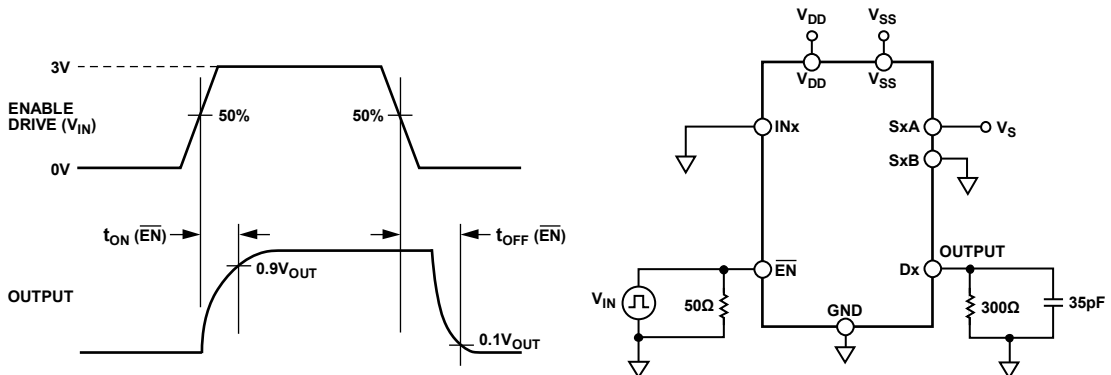

Figure 33. Enable Delay, $t_{ON}(\overline{EN})$, $t_{OFF}(\overline{EN})$

09919-101

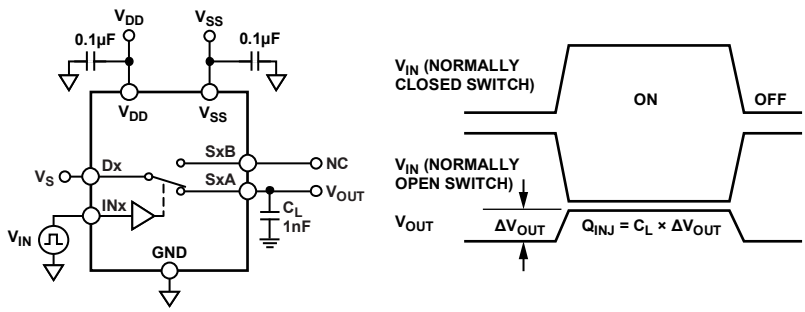

Figure 34. Charge Injection

09919-037

TERMINOLOGY

I_{DD}

I_{DD} represents the positive supply current.

I_{SS}

I_{SS} represents the negative supply current.

V_D, V_S

V_D and V_S represent the analog voltage on Terminal Dx and Terminal Sx, respectively.

R_{ON}

R_{ON} is the ohmic resistance between Terminal Dx and Terminal Sx.

ΔR_{ON}

ΔR_{ON} represents the difference between the R_{ON} of any two channels.

R_{FLAT (ON)}

The difference between the maximum and minimum value of on resistance as measured over the specified analog signal range is represented by R_{FLAT (ON)}.

I_S (Off)

I_S (Off) is the source leakage current with the switch off.

I_D (Off)

I_D (Off) is the drain leakage current with the switch off.

I_D (On), I_S (On)

I_D (On) and I_S (On) represent the channel leakage currents with the switch on.

V_{INL}

V_{INL} is the maximum input voltage for Logic 0.

V_{INH}

V_{INH} is the minimum input voltage for Logic 1.

I_{INL}, I_{INH}

I_{INL} and I_{INH} represent the low and high input currents of the digital inputs.

C_D (Off)

C_D (Off) represents the off switch drain capacitance, which is measured with reference to ground.

C_S (Off)

C_S (Off) represents the off switch source capacitance, which is measured with reference to ground.

C_D (On), C_S (On)

C_D (On) and C_S (On) represent on switch capacitances, which are measured with reference to ground.

C_{IN}

C_{IN} represents digital input capacitance.

t_{ON} ($\overline{\text{EN}}$)

t_{ON} ($\overline{\text{EN}}$) represents the delay time between the 50% and 90% points of the digital input and switch on condition.

t_{OFF} ($\overline{\text{EN}}$)

t_{OFF} ($\overline{\text{EN}}$) represents the delay time between the 50% and 90% points of the digital input and switch off condition.

t_{TRANSITION}

Delay time between the 50% and 90% points of the digital inputs and the switch on condition when switching from one address state to another.

t_D

t_D represents the off time measured between the 80% point of both switches when switching from one address state to another.

Off Isolation

Off isolation is a measure of unwanted signal coupling through an off channel.

Charge Injection

Charge injection is a measure of the glitch impulse transferred from the digital input to the analog output during switching.

Crosstalk

Crosstalk is a measure of unwanted signal that is coupled through from one channel to another as a result of parasitic capacitance.

Bandwidth

Bandwidth is the frequency at which the output is attenuated by 3 dB.

On Response

On response is the frequency response of the on switch.

AC Power Supply Rejection Ratio (ACPSRR)

ACPSRR is a measure of the ability of a part to avoid coupling noise and spurious signals that appear on the supply voltage pin to the output of the switch. The dc voltage on the device is modulated by a sine wave of 0.62 V p-p. The ratio of the amplitude of the signal on the output to the amplitude of the modulation is the ACPSRR.

TRENCH ISOLATION

In the [ADG5233/ADG5234](#), an insulating oxide layer (trench) is placed between the NMOS and the PMOS transistors of each CMOS switch. Parasitic junctions, which occur between the transistors in junction isolated switches, are eliminated, and the result is a completely latch-up proof switch.

In junction isolation, the N and P wells of the PMOS and NMOS transistors form a diode that is reverse-biased under normal operation. However, during overvoltage conditions, this diode can become forward-biased. A silicon controlled rectifier (SCR) type circuit is formed by the two transistors causing a significant amplification of the current that, in turn, leads to latch-up. With trench isolation, this diode is removed, and the result is a latch-up proof switch.

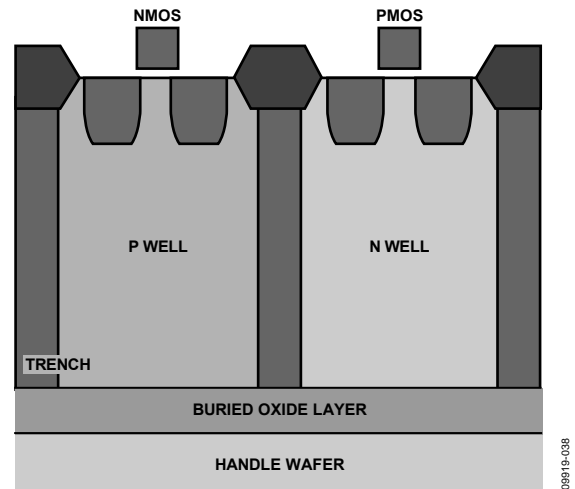

Figure 35. Trench Isolation

09815-038

APPLICATIONS INFORMATION

The ADG52xx family of switches and multiplexers provide a robust solution for instrumentation, industrial, automotive, aerospace, and other harsh environments that are prone to latch-up, which is an undesirable high current state that can lead to device failure and persists until the power supply is turned off.

The [ADG5233/ADG5234](#) high voltage switches allow single-supply operation from 9 V to 40 V and dual supply operation from ± 9 V to ± 22 V.

OUTLINE DIMENSIONS

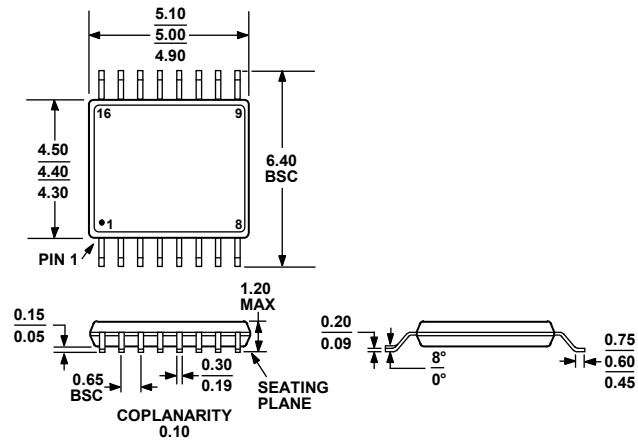

COMPLIANT TO JEDEC STANDARDS MO-153-AB

Figure 36. 16-Lead Thin Shrink Small Outline Package [TSSOP]
(RU-16)

Dimensions shown in millimeters

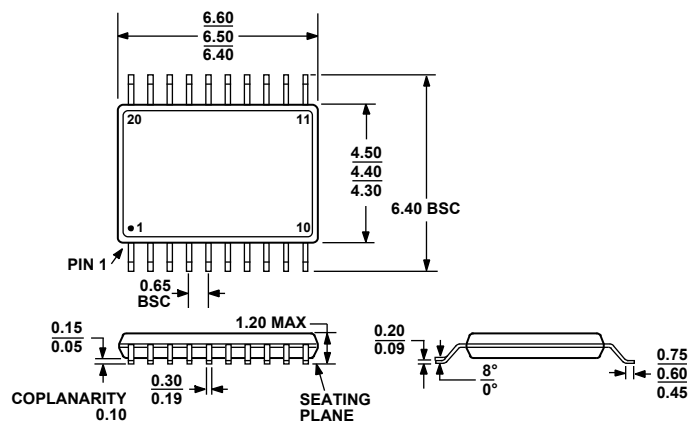

COMPLIANT TO JEDEC STANDARDS MO-153-AC

Figure 37. 20-Lead Thin Shrink Small Outline Package [TSSOP]
(RU-20)

Dimensions shown in millimeters

ORDERING GUIDE

Model ¹	Temperature Range	Description	EN Pin	Package Option
ADG5233BRUZ	-40°C to +125°C	16-Lead Thin Shrink Small Outline Package [TSSOP]	Yes	RU-16
ADG5233BRUZ-RL7	-40°C to +125°C	16-Lead Thin Shrink Small Outline Package [TSSOP]	Yes	RU-16
ADG5234BRUZ	-40°C to +125°C	20-Lead Thin Shrink Small Outline Package [TSSOP]	No	RU-20
ADG5234BRUZ-RL7	-40°C to +125°C	20-Lead Thin Shrink Small Outline Package [TSSOP]	No	RU-20

¹ Z = RoHS Compliant Part.

ADG5233/ADG5234

NOTES

NOTES

ADG5233/ADG5234

NOTES